

## 2004 Spare Parts and Tools Catalogue

*Campagnolo*<sup>®</sup>

## SERIE STERZO • HEADSET • STEUERSATZ • JEU DE DIRECTION

Record™ - Record™ Threadless™ 1" - 1-1/8" .....	1
Record™ Hiddenset™ 1-1/8" - 1-1/8" TTC .....	2
Chorus™ - Chorus™ Threadless™ .....	3
Chorus™ Hiddenset™ 1-1/8" - 1-1/8" TTC™ - Centaur™ Hiddenset™ 1-1/8" .....	4

## REGGISSELLA • SEAT POST • SATTELSTÜTZE • TIGE DE SELLE

Record™ Carbon - Chorus™ Carbon - Centaur™ .....	5
--	---

## MOVIMENTO CENTRALE • BOTTOM BRACKET • INNENLAGER • JEU DE PEDALIER

Record™ - Chorus™ - Record™ Pista™ .....	6
AC-H™ - AC-H™ C-GREY™ - AC-S™ .....	7

## GUARNITURA • CRANKSET • KETTENRADGARNITUR • PEDALIER

Record™ 10s .....	8
Record™ Carbon 10s .....	9
Record™ Triple 10s .....	10
Record™ Pista™ .....	11
Chorus™ 10s .....	12
Chorus™ Carbon 10s .....	13
Chorus™ Triple 10s .....	14
Centaur™ 10s - Centaur™ C-GREY™ 10s .....	15
Centaur™ Triple 10s - Centaur™ Triple C-GREY™ 10s .....	16
Veloce™ 10s - Veloce™ 9s .....	17
Veloce™ Triple 10s - Veloce™ Triple 9s .....	18
Mirage™ Black 9s .....	19
Mirage™ Triple Black 9s .....	20
Xenon™ 9s .....	21
Xenon™ Triple 9s .....	22
Chrono / Triathlon .....	23

## CAMBIO • REAR DERAILLEUR • SCHALTUNG • DERAILLEUR ARRIERE

Record™ 10s .....	24
Chorus™ 10s .....	25
Centaur™ 10s .....	26
Centaur™ C-GREY™ 10s .....	27

**CAMBIO • REAR DERAILLEUR • SCHALTUNG • DERAILLEUR ARRIERE** (continued)

Veloce™ 10s - Veloce™ 9s .....	28
Mirage™ Black 9s .....	29
Xenon™ 9s .....	30

**DERAGLIATORE • FRONT DERAILLEUR • UMWERFER • DERAILLEUR AVANT**

Record™ 10s .....	31
Chorus™ 10s .....	32
Record™ Triple 10 - Chorus™ Triple 10s .....	33
Centaur™ 10s - Centaur™ C-GREY™ 10s .....	34
Centaur™ Triple 10s - Centaur™ Triple C-GREY™ 10s .....	35
Veloce™ 10s .....	36
Veloce™ Triple 10s - Mirage™ Black 9s - Mirage™ Triple Black 9s .....	37
Xenon™ 9s - Xenon™ Triple 9s .....	38

**ERGOPOWER™**

Record™ 10s .....	39
Chorus™ 10s .....	40
Centaur™ 10s - Centaur™ C-GREY™ 10s .....	41
Veloce™ 10s - Veloce™ 9s .....	42
Mirage™ Black 9s .....	43
Xenon™ 9s .....	44
Ergopowers / rear derailleurs cross compatibility .....	45

**FRENI • BRAKES • BREMSEN • FREINS**

Record-D™ “black” - Record-D™ “silver” .....	47
Chorus-D™ .....	48
Centaur™ - Centaur™ C-GREY™ .....	49
Veloce™ .....	50
Mirage™ Black .....	51
Xenon™ .....	52

**BAR-END**

Bar-End Chrono/Triathlon .....	53
--------------------------------	----

**COMANDI FRENO • BRAKE LEVERS • BREMSHEBEL • POIGNEES DE FREINS**

Record™ Carbon .....	54
----------------------	----

## BLOCCAGGI • QUICK RELEASES • SCHNELLSPANNER • BLOCAGES

Record™ - Bora™ - Eurus™ - Ghibli™ - Hyperon™ - Neutron™	55
Chorus™	55
Centaur™ - Proton™ - Zonda™	56
Veloce™ - Scirocco™ - Vento™	56

## MOZZI • HUBS • NABEN • MOYEUX

Record™ / Chorus™ / Centaur™ / Centaur™ C-GREY™ front hub	57
Record™ / Chorus™ / Centaur™ / Centaur™ C-GREY™ rear hub	58
Veloce™ / Mirage™ front and rear hub	59
Record™ Pista™ front and rear hub	60

## GHIERE • LOCKRINGS • VERSCHLUSSRING • ECROUS

Complete range	62
----------------	----

## PIGNONI • SPROCKETS • RITZEL • CASSETTES

Record™ UD™ 10s	63
Record™ UD™ 10s Titanium	64
Chorus™ UD™ 10s	65
Centaur™ UD™ 10s	66
Veloce™ UD™ 10s	67
Veloce™ UD™ 9s (Mirage™ UD™ 9s compatible)	68

## PEDALI • PEDALS • PEDALE • PEDALES

Record™ Pro-Fit PLUS	69
Chorus™ Pro-Fit PLUS	69
Centaur™ Pro-Fit PLUS	69
Other spares	70

## CAVI E GUAINA • CABLES AND CASINGS • KABEL UND HÜLLEN • CABLES ET GAINES

Complete sets	72
Single parts	73

## ERGOBRAIN™

Parts	74
-------	----

**VARI • VARIOUS • VERSCHIEDENES • DIVERSES**

Ergopower™ blocks / 8s adapter kit for 9/10s / HD-Link™ for C10™ UD™ and C-10™ HD-L™ chains / Chain lubricant	76
Blister-packed spare parts	77

**RUOTE • WHEELS • LAUFRÄDER • ROUES**

LOW-PROFILE WHEEL - Hyperon™ clincher / Hyperon™ ULTRA™ clincher 9s / 10s	78
LOW-PROFILE WHEEL - Hyperon™ tubular 9s / 10s	79
LOW-PROFILE WHEEL - Neutron™ 9s / 10s	80
LOW-PROFILE WHEEL - Proton™ 9s / 10s	81
MEDIUM-PROFILE WHEEL - Eurus™ 9s / 10s	82
MEDIUM-PROFILE WHEEL - Zonda™ 9s / 10s	83
MEDIUM-PROFILE WHEEL - Scirocco™ 9s / 10s	84
MEDIUM-PROFILE WHEEL - Vento™ 9s / 10s	85
HIGH-PROFILE WHEEL - Bora™ “full carbon” 9s / 10s	86
HIGH-PROFILE WHEEL - Pista™	87
Bora™ “full carbon” / Hyperon™ tubular / Hyperon™ ULTRA™ clincher front hub	88
Bora™ “full carbon” / Hyperon™ tubular / Hyperon™ ULTRA™ clincher rear hub	89
Hyperon™ clincher / Neutron™ / Eurus™ / Zonda™ front hub	90
Hyperon™ clincher / Neutron™ / Eurus™ / Zonda™ rear hub	91
Proton™ front hub	92
Proton™ rear hub	93
Scirocco™ front and rear hub	94
Pista™ front hub	95
Pista™ rear hub	96
Vento™ front and rear hub	97

**UTENSILI • TOOLS • WERKZEUGE • OUTILS**

Recommended tools	98
Headset	99
Bottom bracket	105
Frame preparation	110
Cranks / chainrings	112
Hubs & wheels	114
Sprockets / chains	117
Service Centers	118

**RECORD™**  
**HS00-RE**

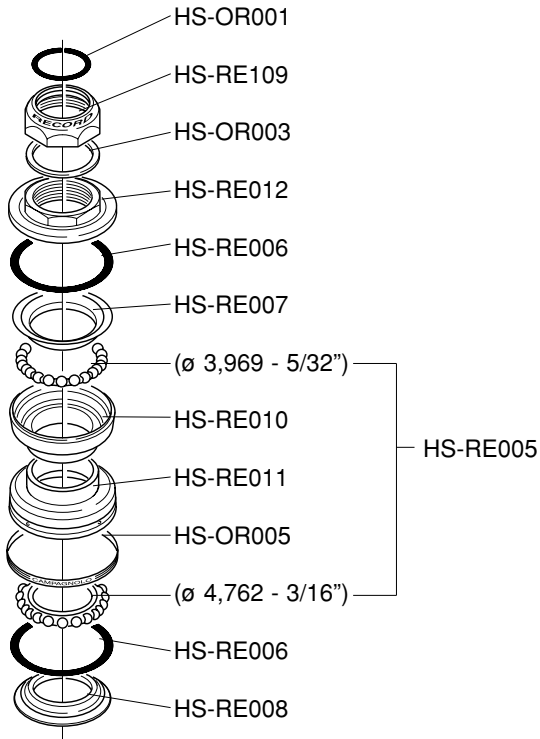

**RECORD™ Threadless™**  
**1": HS00-RETH**  
**1 1/8": HS00-RETHOS**

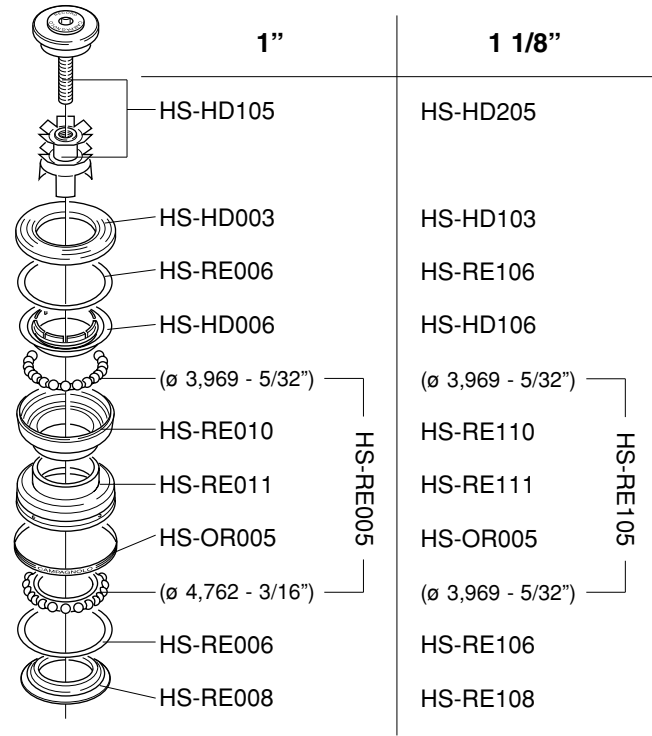

**HEADSET**

## **RECORD™ Hiddenset™** **1 1/8": HS03-REHIOS**

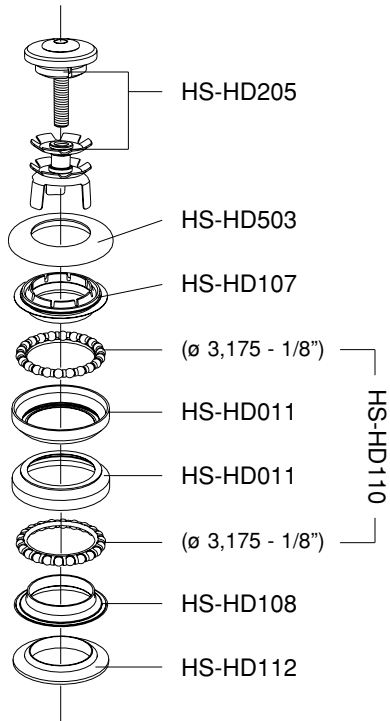

## **RECORD™ Hiddenset™** **TTC™** **1 1/8": HS03-REHIOST**

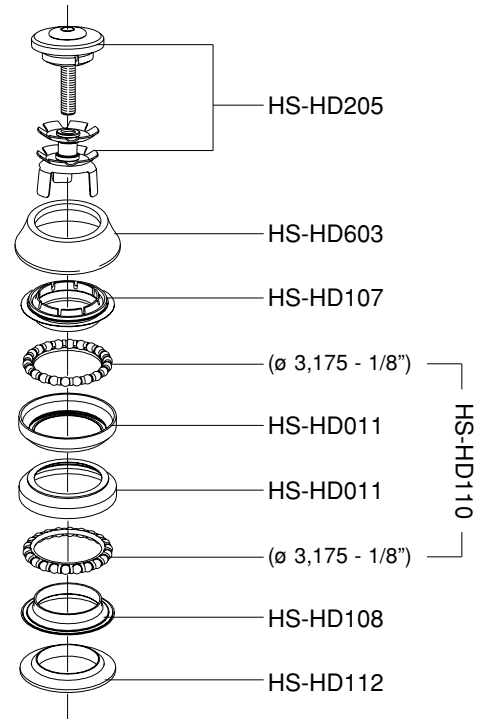

**CHORUS™**  
**HS00-CH**

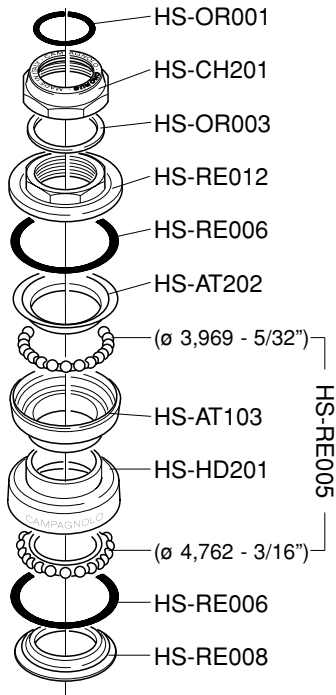

**CHORUS™**  
**THREADLESS™**  
**HS00-CHTH**

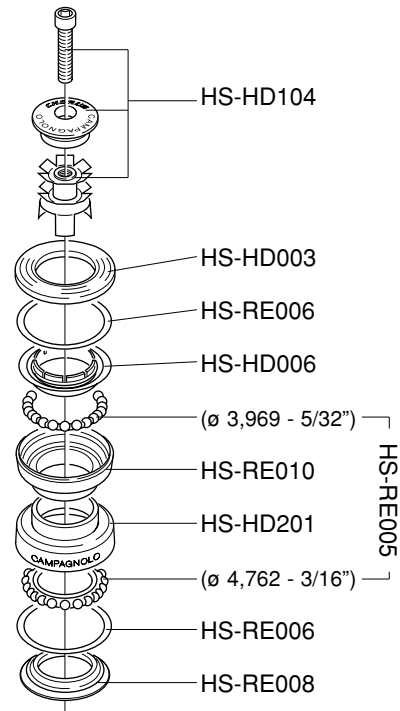



# HEADSET

## **CHORUS™ Hiddenset™**

1 1/8": HS03-CHHIOS

## **CENTAUR™ Hiddenset™**

1 1/8": HS4-CEH8

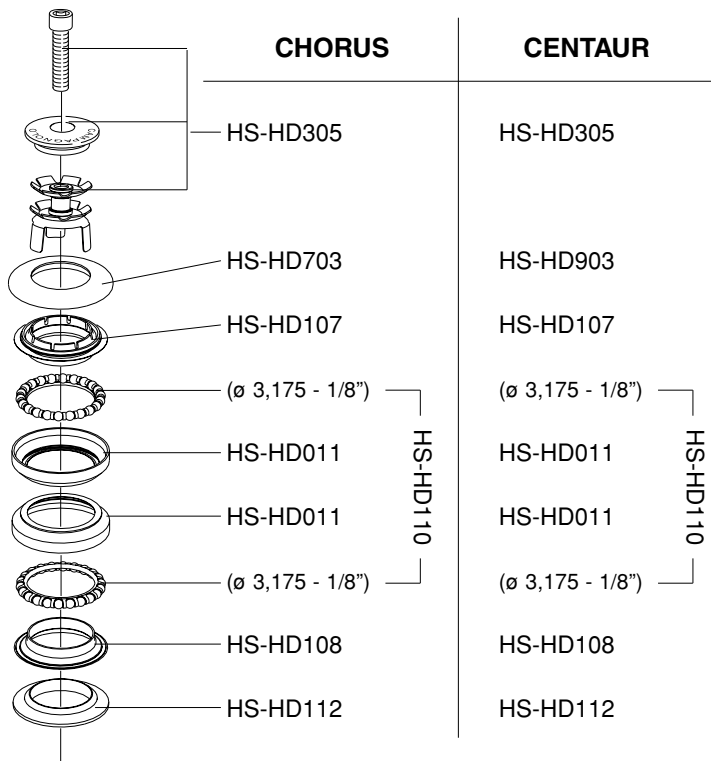

## **CHORUS™ Hiddenset™**

**TTC™**

1 1/8": HS03-CHHIOST

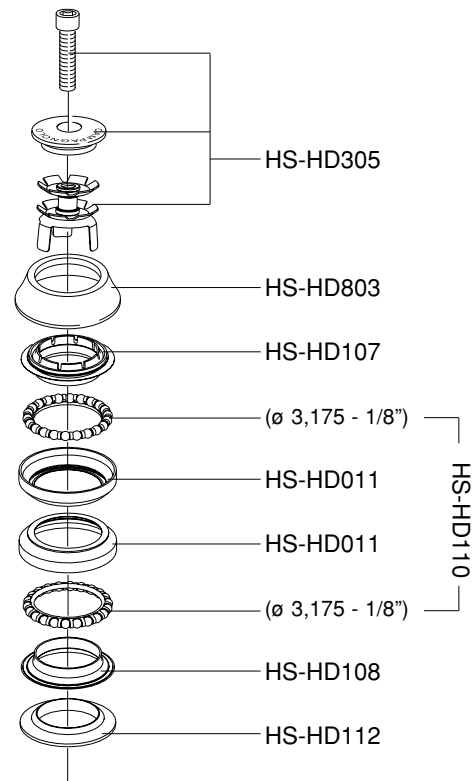

**RECORD™**  
**Carbon**  
**SP4-RE27C**  
**SP4-RE31CL**  
**SP4-RE32CL**

**CHORUS™**  
**Carbon**  
**SP4-CH27C**  
**SP4-CH31CL**  
**SP4-CH32CL**

**CENTAUR™**  
**SP4-CE27**

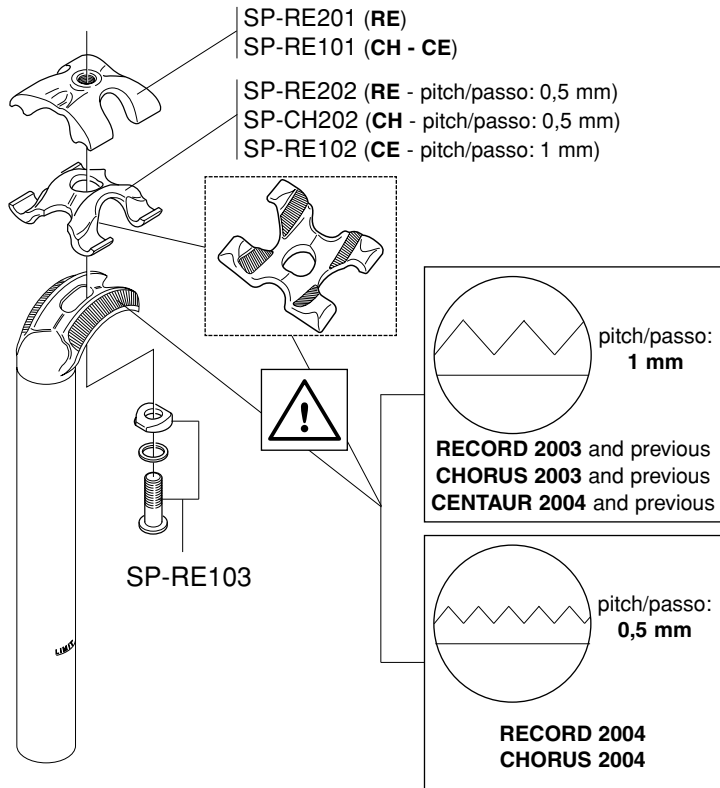

**5-SP-RE104** (5 pcs.)  
**50-SP-RE104** (50 pcs.)

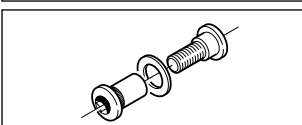

**SP-RE106** (1 pc.)  
**5-SP-RE106** (5 pcs.)  
 per tubi Ø 31,6 / 31,9 mm  
 for tubes Ø 31,6 / 31,9 mm

**SP-RE108** (1 pc.)  
**5-SP-RE108** (5 pcs.)  
 per tubi Ø 34,9 / 35,2 mm  
 for tubes Ø 34,9 / 35,2 mm

**SP-RE107** (1 pc.)  
**5-SP-RE107** (5 pcs.)  
 per tubi Ø 35,5 / 35,8 mm  
 for tubes Ø 35,5 / 35,8 mm

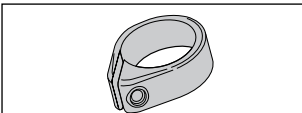

**! WARNING!**

With the 2004 product range the pitch of all the heads (5 - Fig. 1) on the RECORD™ and CHORUS™ seat post tubes and the relevant seat clamps (1 - Fig. 1) has been reduced from 1 mm to 0.5 mm. A seat clamp (1 - Fig. 1) with 0.5 mm pitch is not compatible with heads (5 - Fig. 1) with a 1-mm pitch and vice versa. NEVER use seat clamps and heads that are not compatible with one another; the seat clamp could slip causing you to lose control of your bicycle, resulting in an accident, personal injury or death.

**! ATTENZIONE!**

A partire dalla gamma 2004 è stato dimezzato il passo (da 1 mm a 0,5 mm) di tutte le teste (5 - Fig. 1) e delle relative staffe inferiori (1 - Fig. 1) dei reggisella RECORD™ e CHORUS™. Una staffa (1 - Fig. 1) con passo da 0,5 mm non è compatibile con le teste (5 - Fig. 1) con passo da 1 mm e viceversa. Non utilizzate MAI staffe e teste non compatibili tra loro; la staffa potrebbe slittare e potreste incorrere in incidenti, lesioni fisiche o morte.

**RECORD™ 102 mm**  
**BB99-RE02IT**  
**BB99-RE02BC**

**RECORD™ TRIPLE**  
**111 mm**  
**asymmetrical**  
**BB02-RE11IT**  
**BB02-RE11BC**

**CHORUS™ TRIPLE**  
**111 mm**  
**asymmetrical**  
**BB03-CH11IT**  
**BB03-CH11BC**

**CHORUS™ 102 mm**  
**BB99-CH02IT**  
**BB99-CH02BC**

**RECORD™ PISTA**  
**111 mm**  
**BB01-REPIIT**  
**BB01-REPIBC**

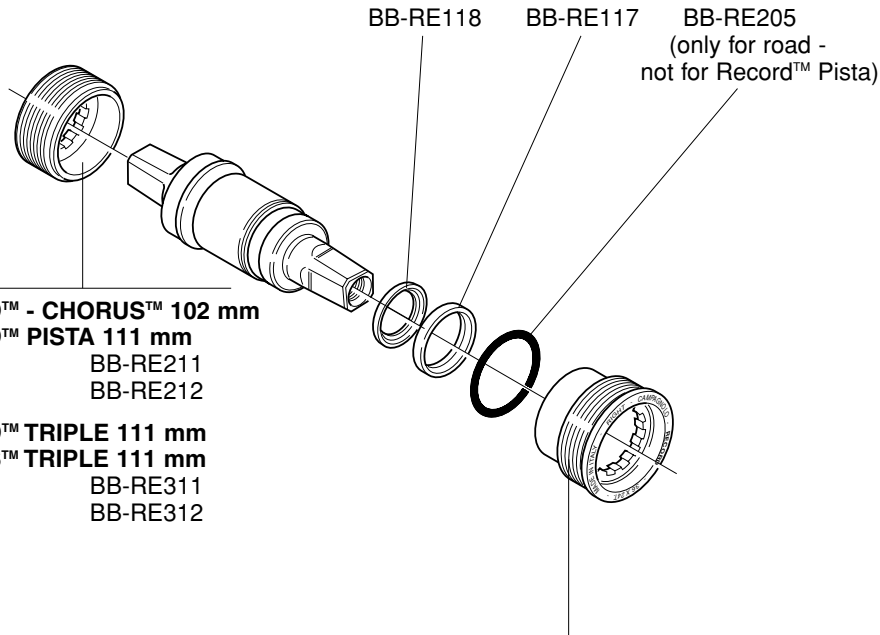

**RECORD™ - CHORUS™ 102 mm**  
**RECORD™ PISTA 111 mm**  
**Italian: BB-RE211**  
**English: BB-RE212**

**RECORD™ TRIPLE 111 mm**  
**CHORUS™ TRIPLE 111 mm**  
**Italian: BB-RE311**  
**English: BB-RE312**

**RECORD™ 102 mm / RECORD™ PISTA 111 mm**  
**Italian: BB-RE213**  
**English: BB-RE214**

**RECORD™ TRIPLE 111 mm**  
**Italian: BB-RE313**  
**English: BB-RE314**

**CHORUS™ TRIPLE 111 mm**  
**Italian: BB-CH313**  
**English: BB-CH314**

**CHORUS™ 102 mm**  
**Italian: BB-CH213**  
**English: BB-CH214**

## **AC-H™**

111 mm

**BB00-AH11IT**  
**BB00-AH11BC**

115,5 mm

**BB00-AH15IT**  
**BB00-AH15BC**

## **AC-H™ C-GREY**

111 mm

**BB4-AHG1I**  
**BB4-AHG1G**

115,5 mm

**BB4-AHG5I**  
**BB4-AHG5G**

## **AC-S™**

111 mm

**BB00-AS11IT**  
**BB00-AS11BC**

115,5 mm

**BB4-AS5I**  
**BB4-AS5G**

**ITALIAN:** BB-AH001 (AC-H™, AC-S™)  
BB-AHG001 (AC-H™ CENTURY GREY™)

**ENGLISH:** BB-AH003 (AC-H™, AC-S™)  
BB-AHG003 (AC-H™ CENTURY GREY™)

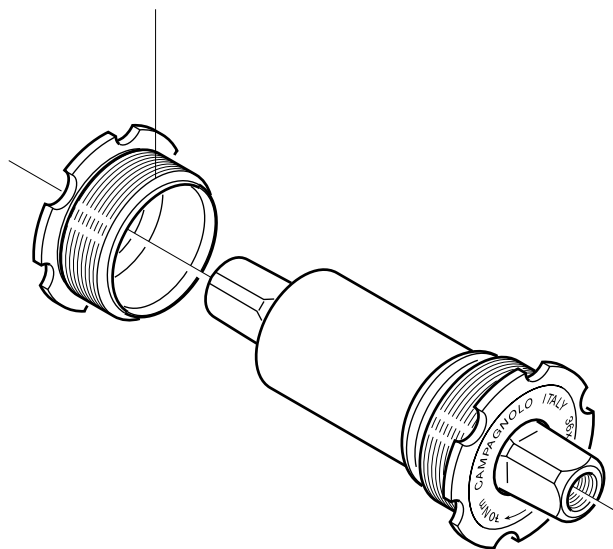

## **RECORD™ 10s** **FC4-RE...X**

<b>A</b>	170 mm	FC-RE760
	172,5 mm	FC-RE762
	175 mm	FC-RE764
	177,5 mm	FC-RE766
	180 mm	FC-RE768

<b>B</b>	170 mm	FC-RE761
	172,5 mm	FC-RE763
	175 mm	FC-RE765
	177,5 mm	FC-RE767
	180 mm	FC-RE769

<b>C</b>	Z39	FC-RE139
	Z42	FC-RE342

<b>D</b>	Z52 for 39	FC-RE752
	Z52 for 42	FC-RE852
	Z53 for 39	FC-RE553

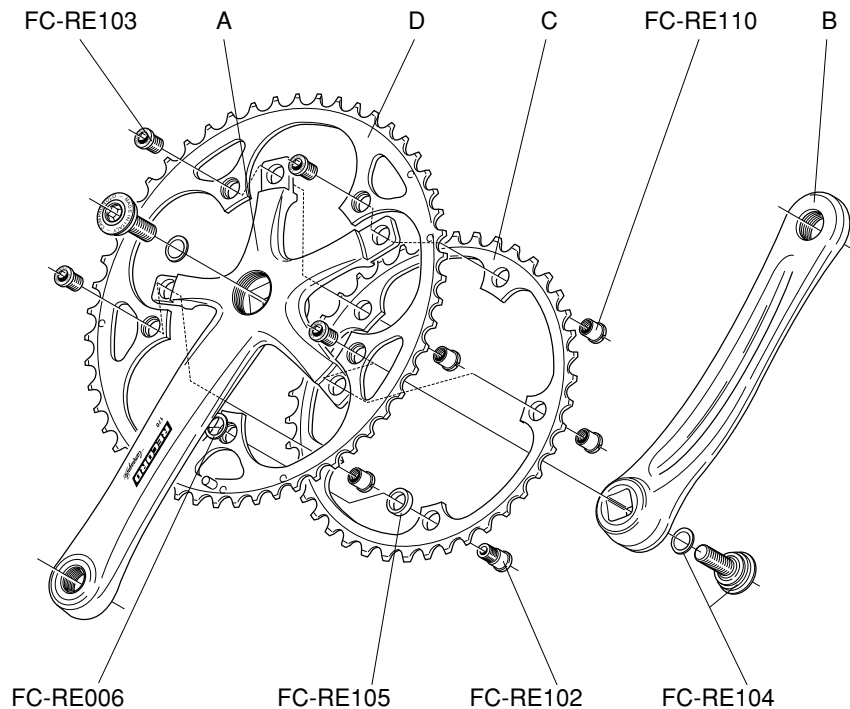

**RECORD™**  
**Carbon 10s**  
**FC4-RE...C**

A	170 mm	FC-RE860C
	172,5 mm	FC-RE862C
	175 mm	FC-RE864C
B	170 mm	FC-RE861C
	172,5 mm	FC-RE863C
	175 mm	FC-RE865C
C	Z39	FC-RE139
	Z42	FC-RE342
D	Z52 for 39	FC-RE752
	Z52 for 42	FC-RE852
	Z53 for 39	FC-RE553

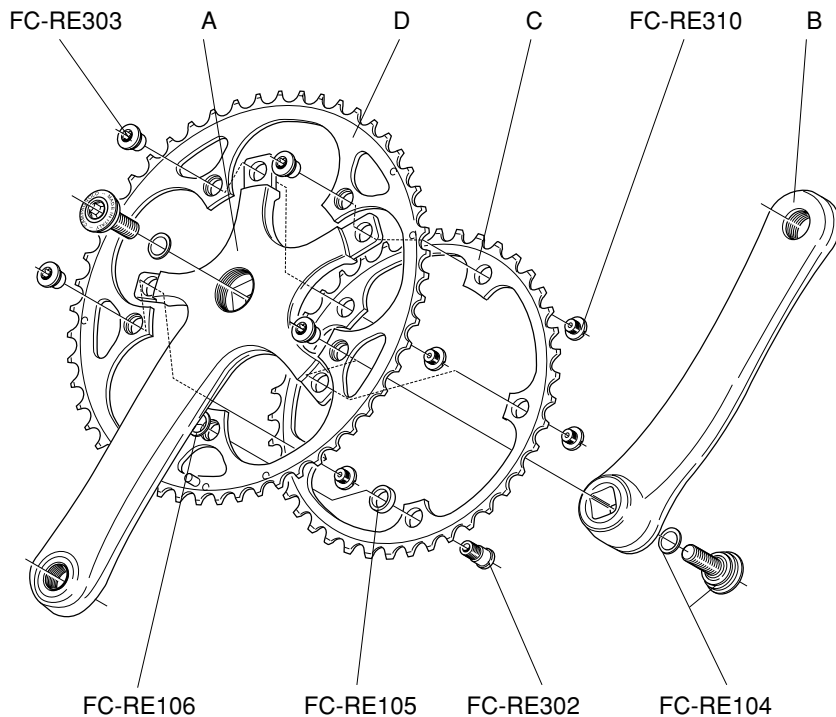

**RECORD™**  
**TRIPLE 10s**  
**FC4-RE....X**

<b>A</b>	170 mm	FC-RE830
	172,5 mm	FC-RE832
	175 mm	FC-RE834
<b>B</b>	170 mm	FC-RE831
	172,5 mm	FC-RE833
	175 mm	FC-RE835
<b>C</b>	Z30	FC-RE130
<b>D</b>	Z40 for 30	FC-RE140
	Z42 for 30	FC-RE642
<b>E</b>	Z50 for 40	FC-RE150
	Z53 for 42	FC-RE653

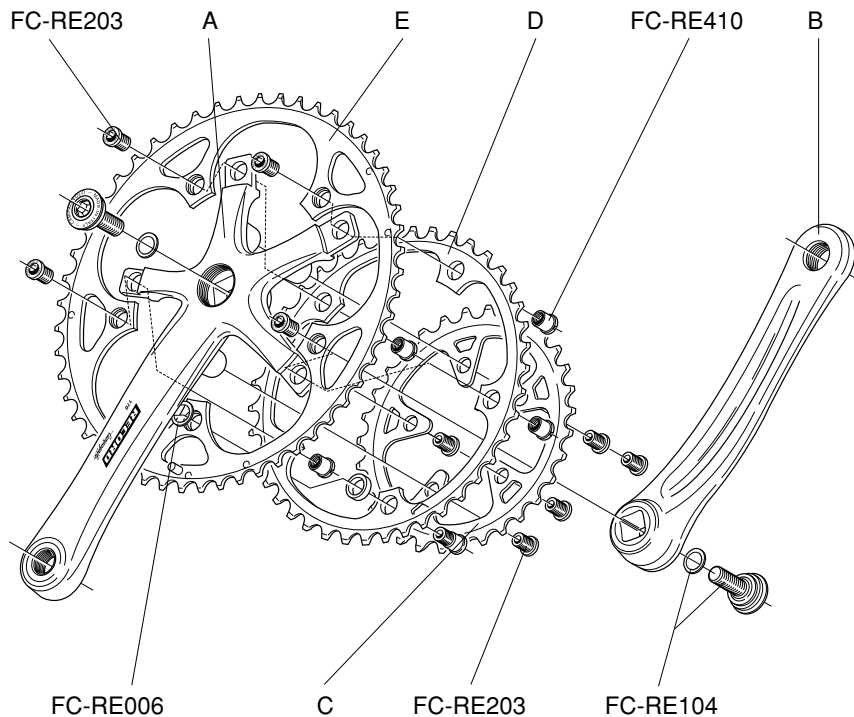

**RECORD™**  
**PISTA**  
**FC01-REPI...**

A	165 mm	FC-PI365
	170 mm	FC-PI370
B	165 mm	FC-PI465
	170 mm	FC-PI470
C	Z47	FC-PI047
	Z48	FC-PI048
	Z49	FC-PI049
	Z50	FC-PI050
	Z51	FC-PI051
	Z52	FC-PI052

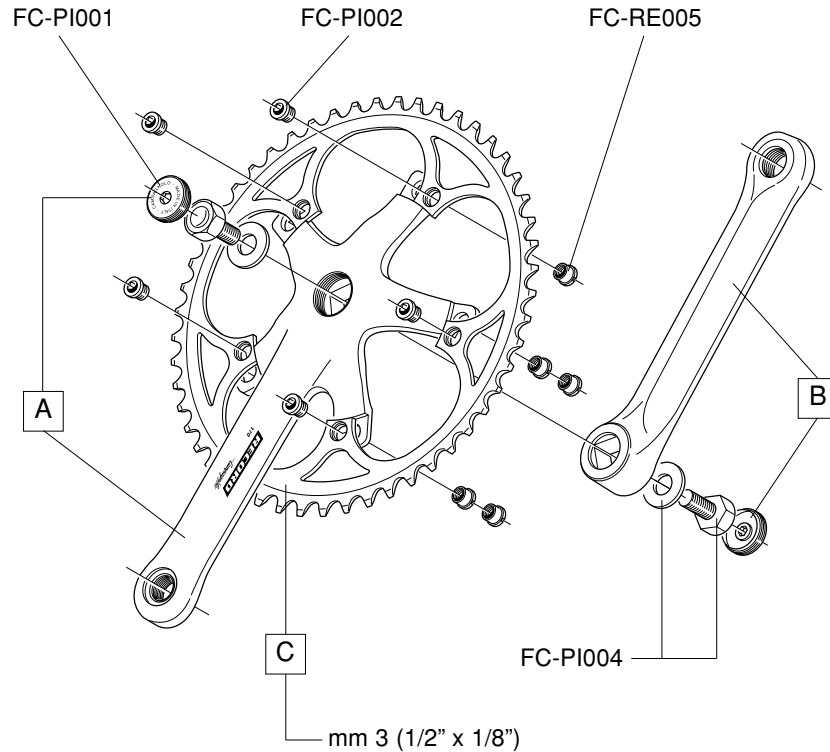



## **CHORUS™ 10s** **FC4-CH...X**

<b>A</b>	170 mm	FC-CH840
	172,5 mm	FC-CH842
	175 mm	FC-CH844
<b>B</b>	170 mm	FC-CH771
	172,5 mm	FC-CH773
	175 mm	FC-CH775
<b>C</b>	Z39	FC-RE039
	Z42	FC-RE142
<b>D</b>	Z52 for 39	FC-RE652
	Z52 for 42	FC-RE552
	Z53 for 39	FC-RE453

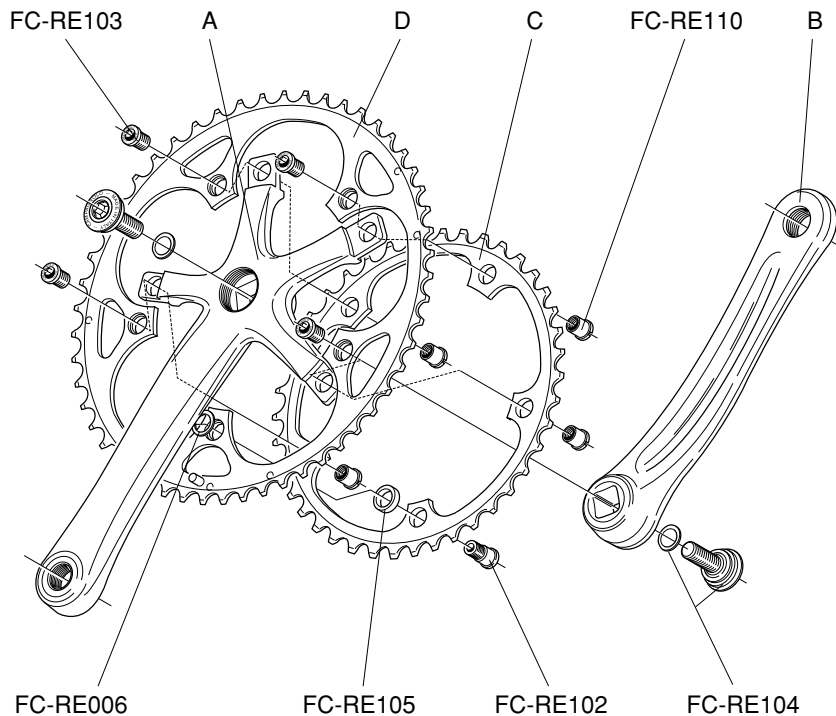

**CHORUS™**  
**Carbon 10s**  
**FC4-CH...C**

A	170 mm	FC-CH870C
	172,5 mm	FC-CH872C
	175 mm	FC-CH874C
B	170 mm	FC-CH871C
	172,5 mm	FC-CH873C
	175 mm	FC-CH875C
C	Z39	FC-RE039
	Z42	FC-RE142
D	Z52 for 39	FC-RE652
	Z52 for 42	FC-RE552
	Z53 for 39	FC-RE453

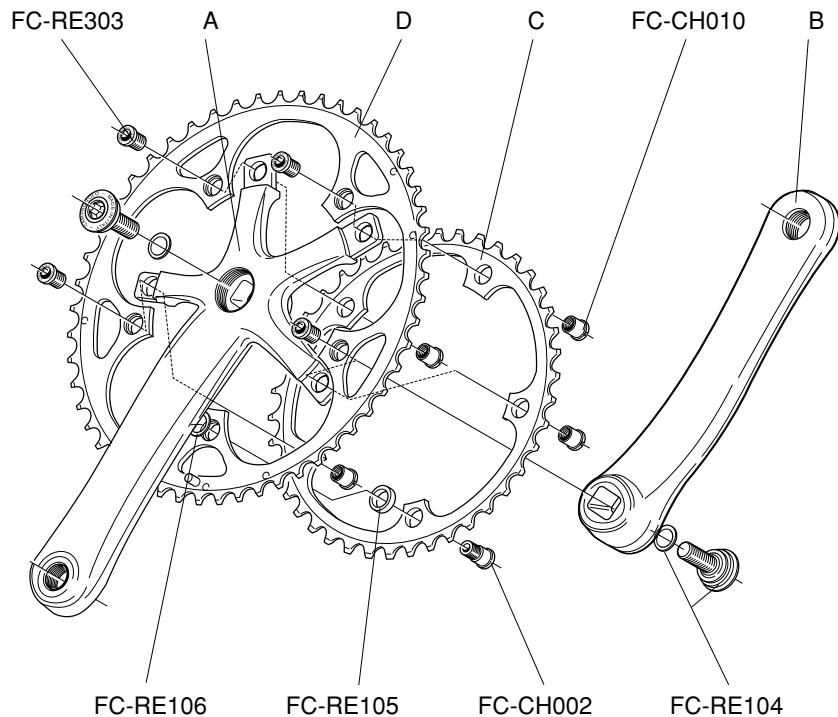

**CHORUS™**  
**TRIPLE 10s**  
**FC4-CH....X**

<b>A</b>	170 mm	FC-CH846
	172,5 mm	FC-CH848
	175 mm	FC-CH850
<b>B</b>	170 mm	FC-CH847
	172,5 mm	FC-CH849
	175 mm	FC-CH851
<b>C</b>	Z30	FC-RE030
<b>D</b>	Z40 for 30	FC-RE040
	Z42 for 30	FC-RE442
<b>E</b>	Z50 for 40	FC-RE050
	Z53 for 42	FC-RE053

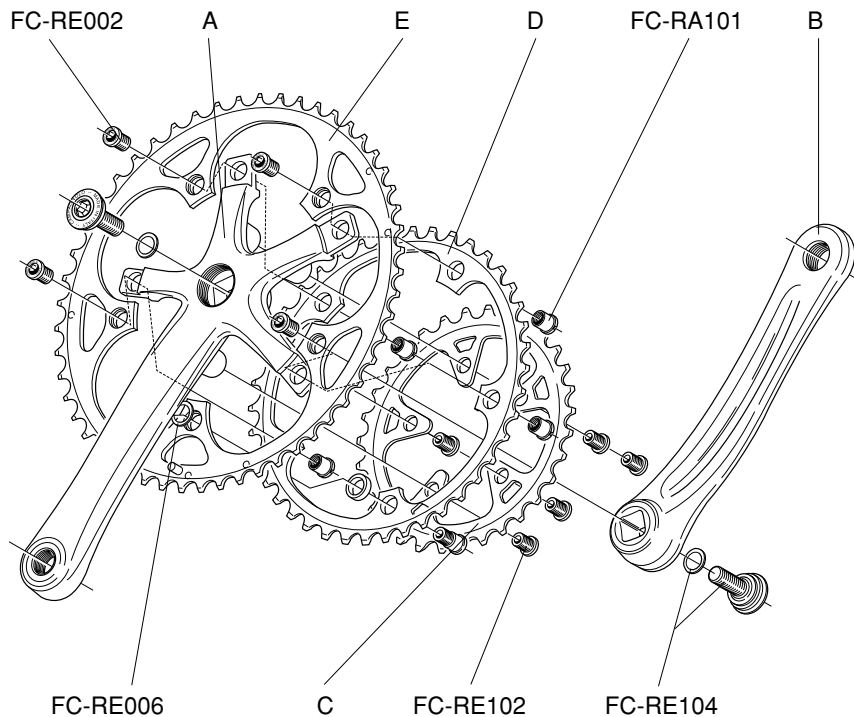

# CENTAUR™ 10s

FC4-CE...X

# CENTAUR™ CENTURY GREY™ 10s

FC4-CEG...X

		CENTAUR™	CENTAUR™ C-GREY
A	170 mm	FC-CE920	FC-CEG910
	172,5 mm	FC-CE922	FC-CEG912
	175 mm	FC-CE924	FC-CEG914
B	170 mm	FC-CE921	FC-CEG911
	172,5 mm	FC-CE923	FC-CEG913
	175 mm	FC-CE925	FC-CEG915
C	Z39	FC-RE039	FC-CEG039
	Z42	FC-RE142	FC-CEG042
D	Z52 for 39	FC-CH252	FC-CEG052
	Z52 for 42	FC-CH452	FC-CEG152
	Z53 for 39	FC-CH253	FC-CEG053

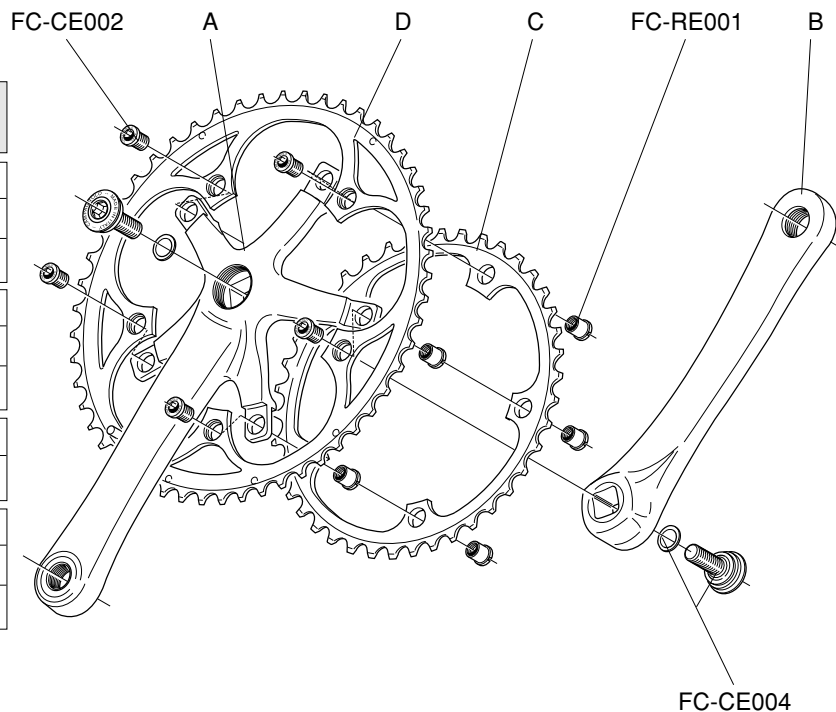

## **CENTAUR™ TRIPLE 10s**

**FC4-CE....X**

## **CENTAUR™ TRIPLE CENTURY GREY™ 10s**

**FC4-CEG....X**

		CENTAUR™	CENTAUR™ C-GREY
<b>A</b>	170 mm	FC-CE950	FC-CEG916
	175 mm	FC-CE952	FC-CEG918
<b>B</b>	170 mm	FC-CE951	FC-CEG917
	175 mm	FC-CE953	FC-CEG919
<b>C</b>	Z30	FC-RE030	FC-CEG030
<b>D</b>	Z40 for 30	FC-CE040	FC-CEG040
	Z42 for 30	FC-CE042	FC-CEG142
<b>E</b>	Z50 for 40	FC-CE050	FC-CEG050
	Z53 for 42	FC-CE053	FC-CEG053

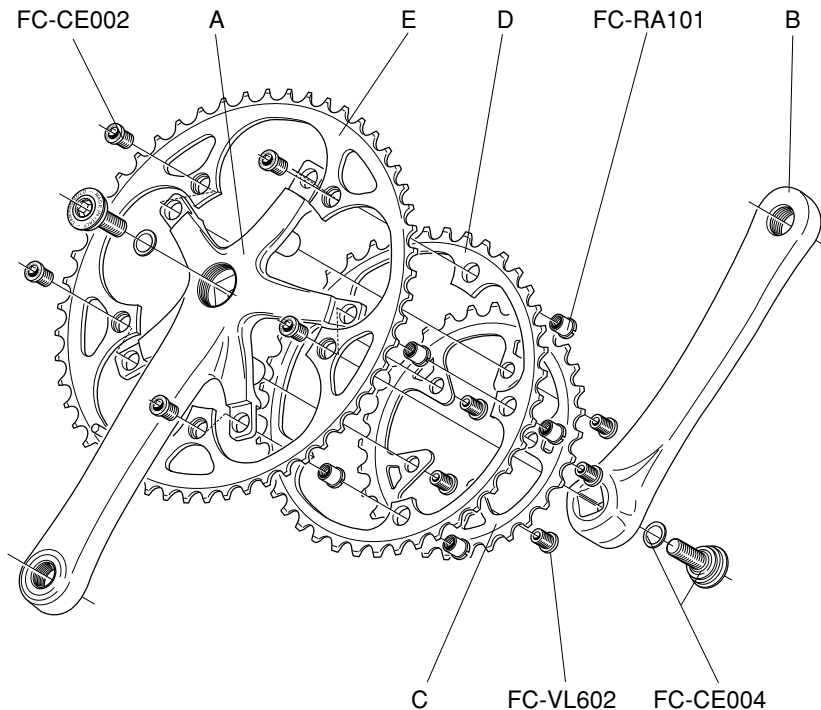

**VELOCE™ 10s**

**FC4-VL...X**

**VELOCE™ 9s**

**FC01-VL...**

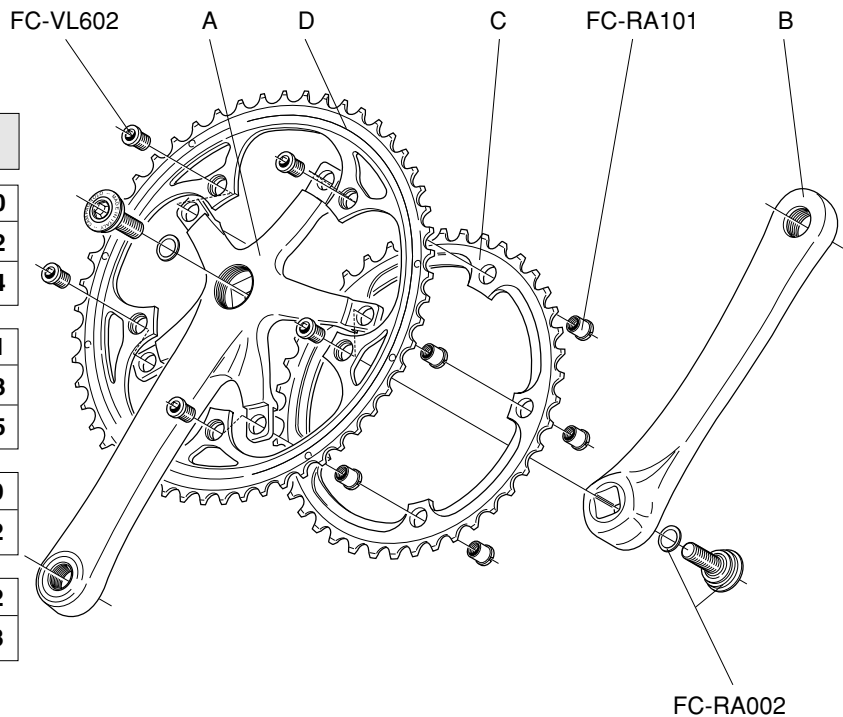

		10s	9s
A	170 mm	FC-VL852	FC-VL790
	172,5 mm	FC-VL854	FC-VL792
	175 mm	FC-VL856	FC-VL794
B	170 mm	FC-VL853	FC-VL791
	172,5 mm	FC-VL855	FC-VL793
	175 mm	FC-VL857	FC-VL795
C	Z39	FC-VL039	FC-MI039
	Z42	FC-VL242	FC-MI042
D	Z52 for 42	FC-VL252	FC-MI352
	Z53 for 39	FC-VL053	FC-MI153

**CRANKSET**

**VELOCE™ TRIPLE 10s**

**FC4-VL....X**

**VELOCE™ TRIPLE 9s**

**FC01-VL....**

		10s	9s
A	170 mm	FC-VL880	FC-VL796
	175 mm	FC-VL882	FC-VL798
B	170 mm	FC-VL881	FC-VL797
	175 mm	FC-VL883	FC-VL799
C	Z30	FC-VL030	FC-MI730
D	Z42 for 30	FC-VL342	FC-VL142
E	Z52 for 42	FC-VL252	FC-MI352

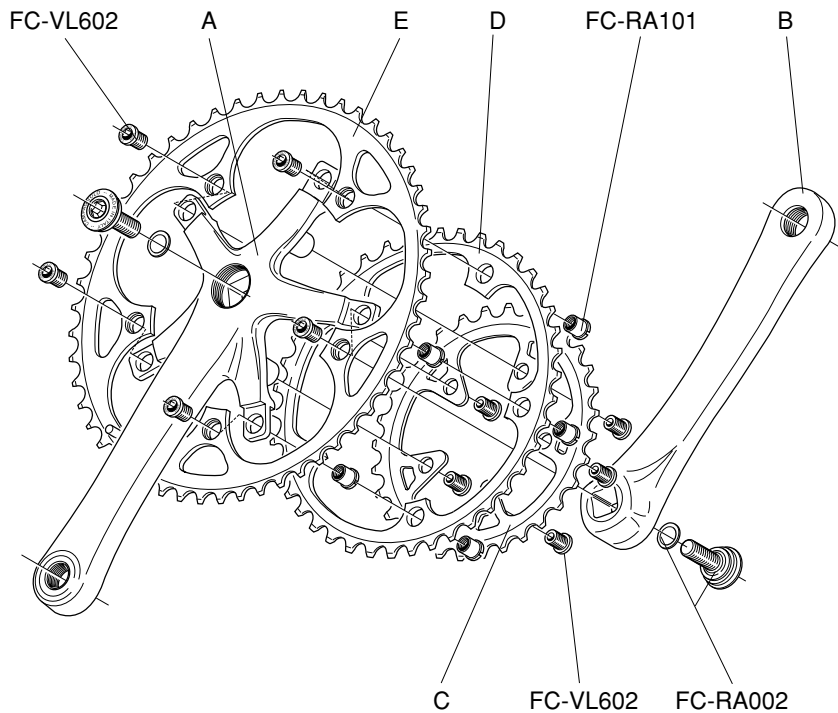

# MIRAGE™ BLACK 95

FC4-MIB...

# MIRAGE™ 95

FC4-MI...

	MIRAGE™ BLACK	MIRAGE™
--	------------------	---------

A	170 mm	FC-MIB894	FC-MI810
	172,5 mm	FC-MIB896	FC-MI812
	175 mm	FC-MIB898	FC-MI814

B	170 mm	FC-MIB895	FC-MI811
	172,5 mm	FC-MIB897	FC-MI813
	175 mm	FC-MIB899	FC-MI815

C	Z39	FC-MIB039
	Z42	FC-MIB042

D	Z52 for 42	FC-MIB052
	Z53 for 39	FC-MIB053

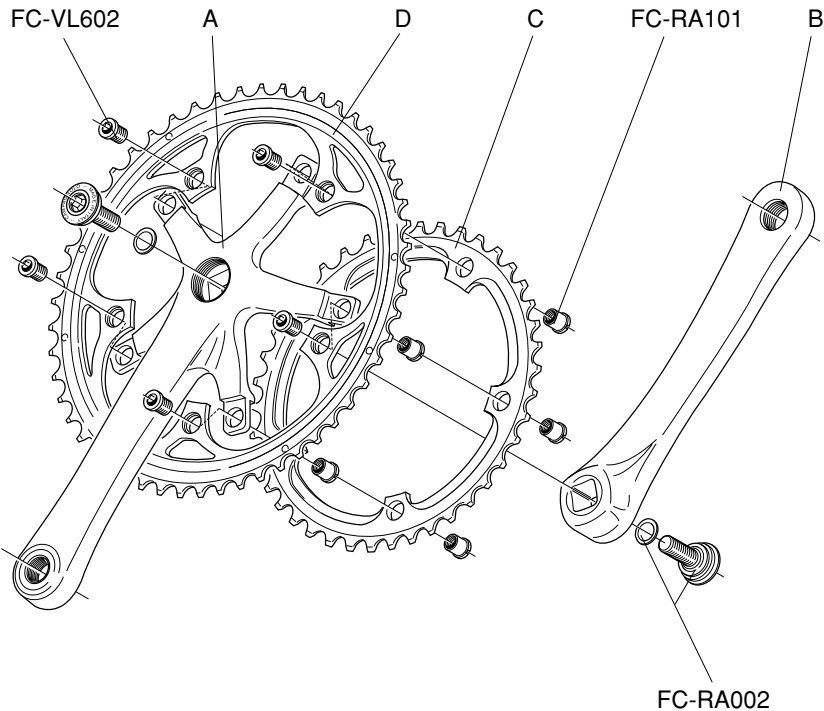



## MIRAGE™ TRIPLE BLACK 95

FC4-MIB....

## MIRAGE™ TRIPLE 9s

FC4-MI....

		MIRAGE™ BLACK	MIRAGE™
A	170 mm	FC-MIB900	FC-XE806
	175 mm	FC-MIB902	FC-XE808
B	170 mm	FC-MIB901	FC-XE807
	175 mm	FC-MIB903	FC-XE809
C	Z30	FC-MIB030	
D	Z42 for 30	FC-MIB142	
E	Z52 for 42	FC-MIB052	

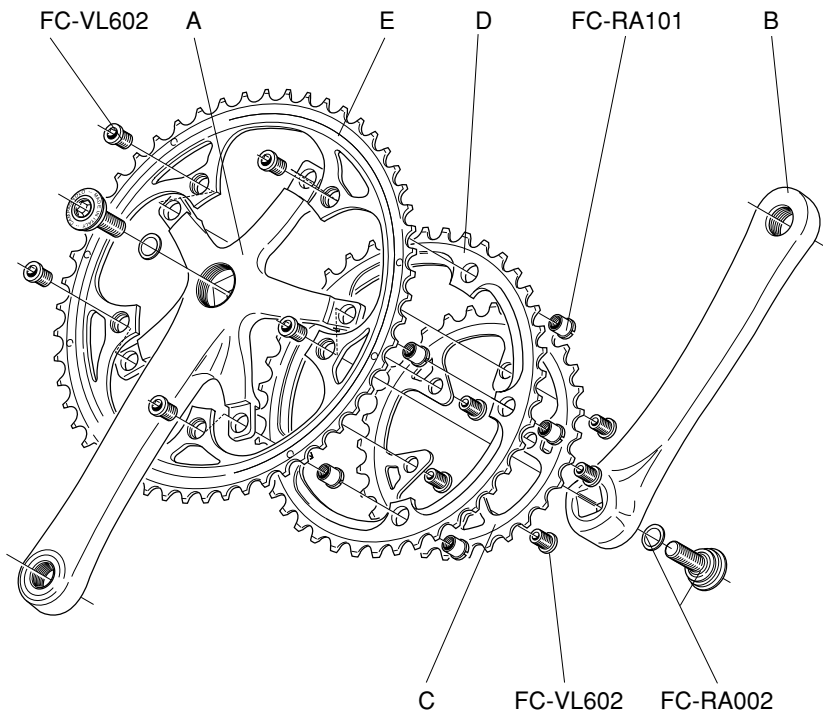

**XENON™ 9s**  
**FC02-XE...**

A	170 mm	FC-XE800
	175 mm	FC-XE804
B	170 mm	FC-XE801
	175 mm	FC-XE805
C	Z39	FC-MI139
D	Z52 for 39	FC-XE052

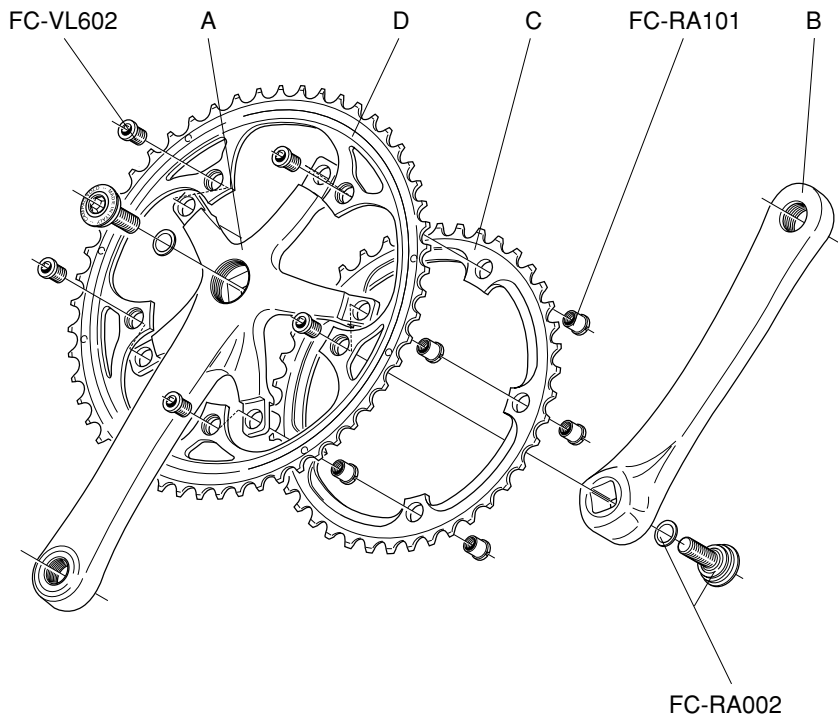

**XENON™**  
**TRIPLE 9s**  
**FC02-XE....**

A	170 mm	FC-XE806
	175 mm	FC-XE808
B	170 mm	FC-XE807
	175 mm	FC-XE809
C	Z30	FC-MI030
D	Z42 for 30	FC-XE142
E	Z52 for 42	FC-XE252

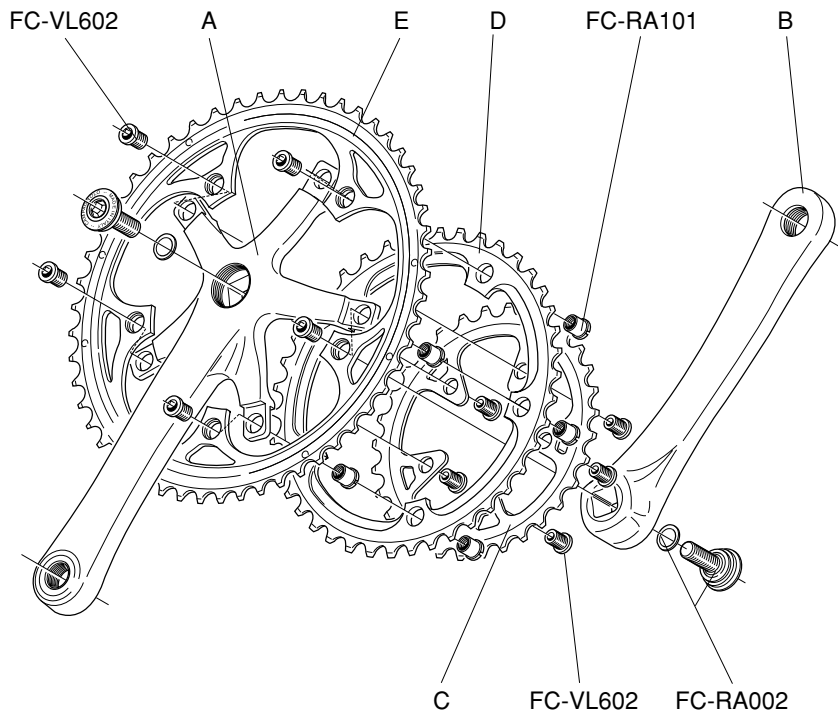

**CHRONO /  
TRIATHLON  
CHAINRINGS**

9s	RECORD™ 10s	CHORUS™ 10s
FC-TH155: 55 for 42	FC-RETH155: 55 for 42	FC-CHTH155: 55 for 42
FC-TH255: 55 for 44	FC-RETH255: 55 for 44	FC-CHTH255: 55 for 44

9s	RECORD™ 10s	CHORUS™ 10s
FC-TH154: 54 for 42	FC-RETH154: 54 for 42	FC-CHTH154: 54 for 42
FC-TH254: 54 for 44	FC-RETH254: 54 for 44	FC-CHTH254: 54 for 44

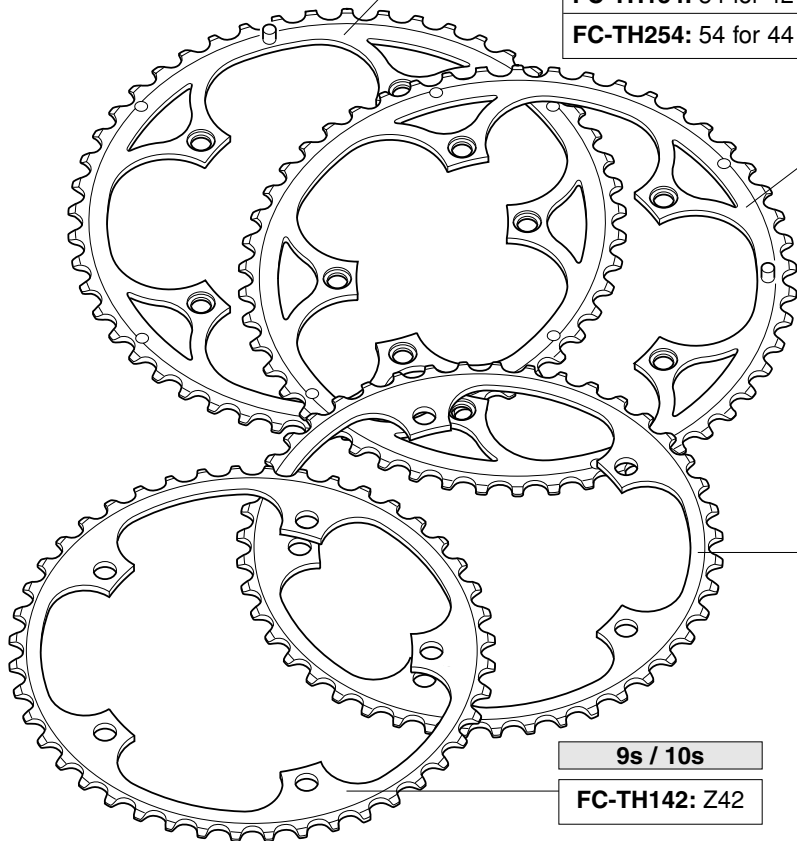

9s / 10s
FC-TH144: Z44

9s / 10s
FC-TH142: Z42

**RECORD™ 10s**

**RD4-REXS  
RD4-REXM  
RD4-REXL**

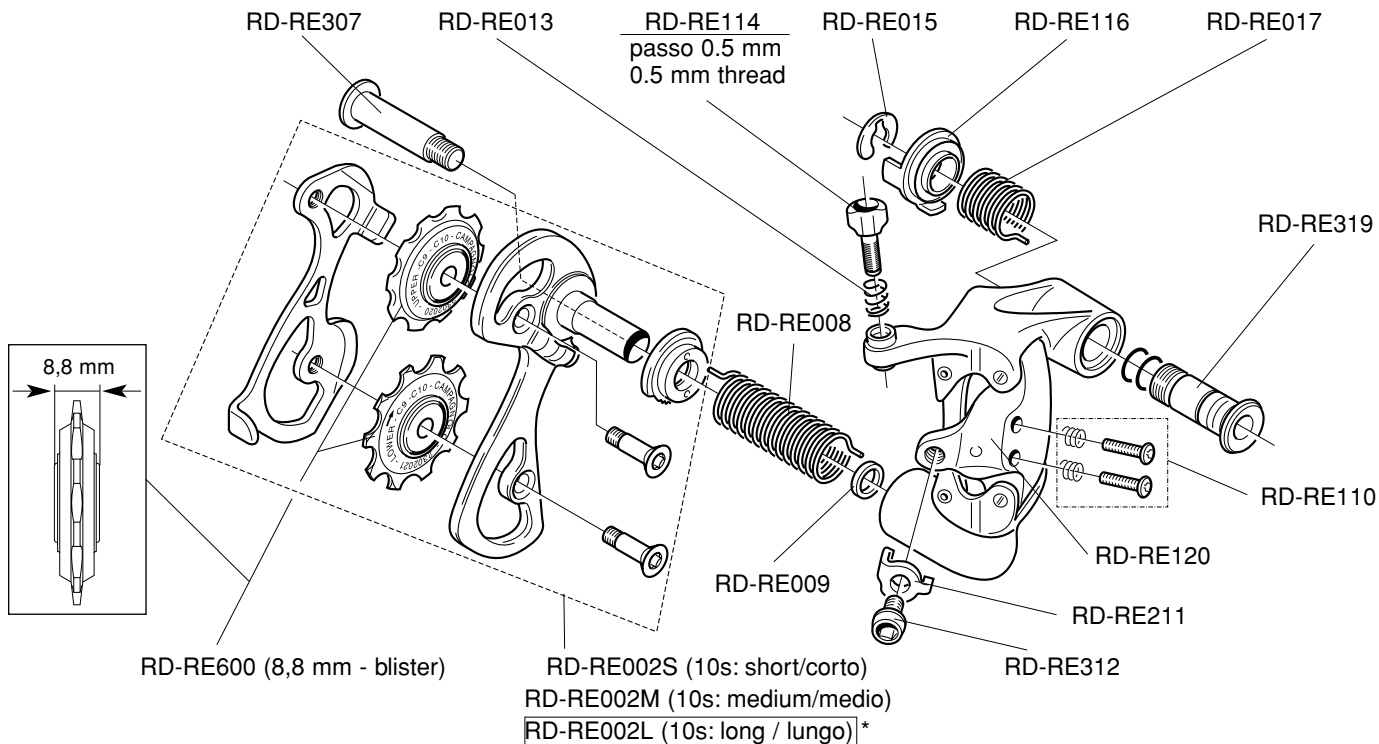

\* solo per RD4-REXL - non compatibile con RD4-REXS e RD4-REXM

\* only for RD4-REXL - not compatible with RD4-REXS and RD4-REXM

# CHORUS™ 10s

RD4-CHXS  
RD4-CHXM  
RD4-CHXL

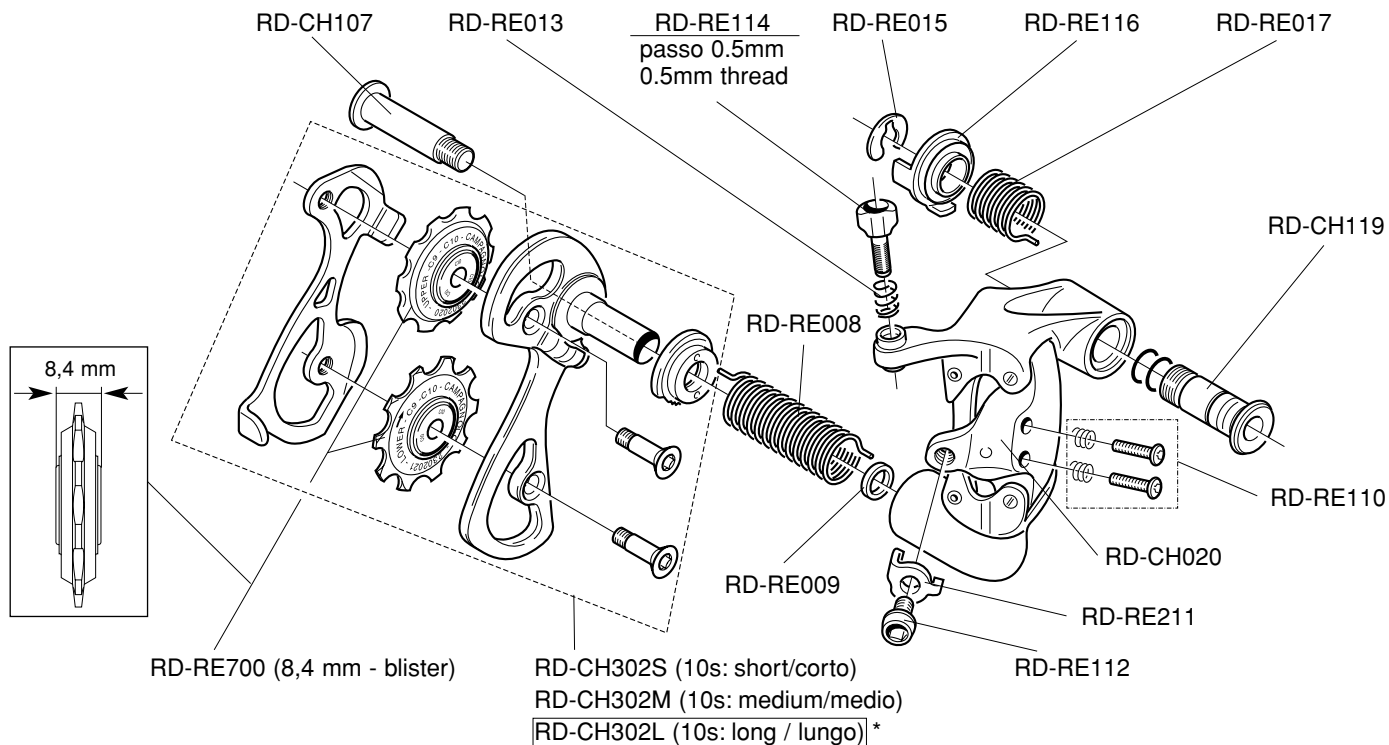

\* solo per RD4-CHXL - non compatibile con RD4-CHXS e RD4-CHXM

\* only for RD4-CHXL - not compatible with RD4-CHXS and RD4-CHXM

## CENTAUR™ 10s

RD4-CEXS  
RD4-CEXM  
RD4-CEXL

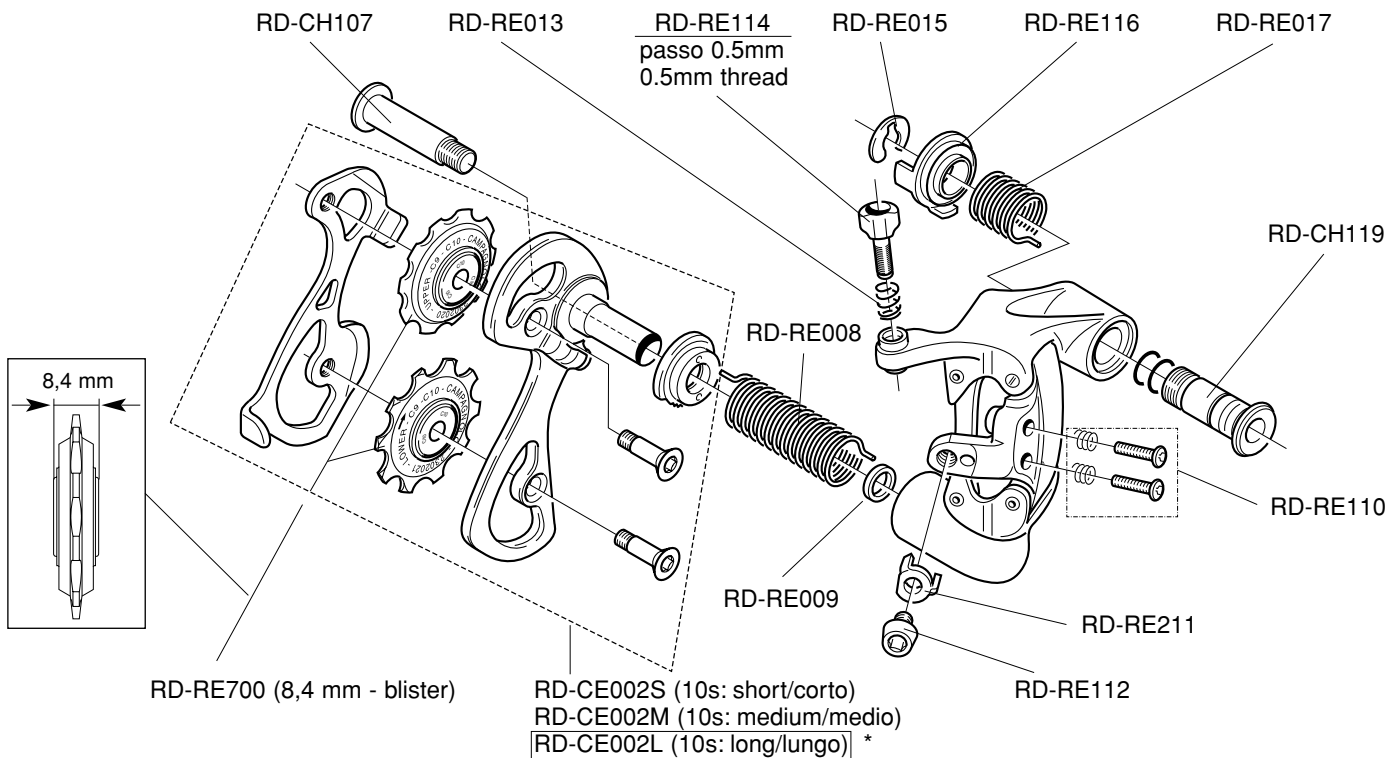

\* solo per RD4-CEXL - non compatibile con RD4-CEXS e RD4-CEXM  
\* only for RD4-CEXL - not compatible with RD4-CEXS and RD4-CEXM

# CENTAUR™ CENTURY GREY™ 10s

RD4-CEGXS

RD4-CEGXM

RD4-CEGXL

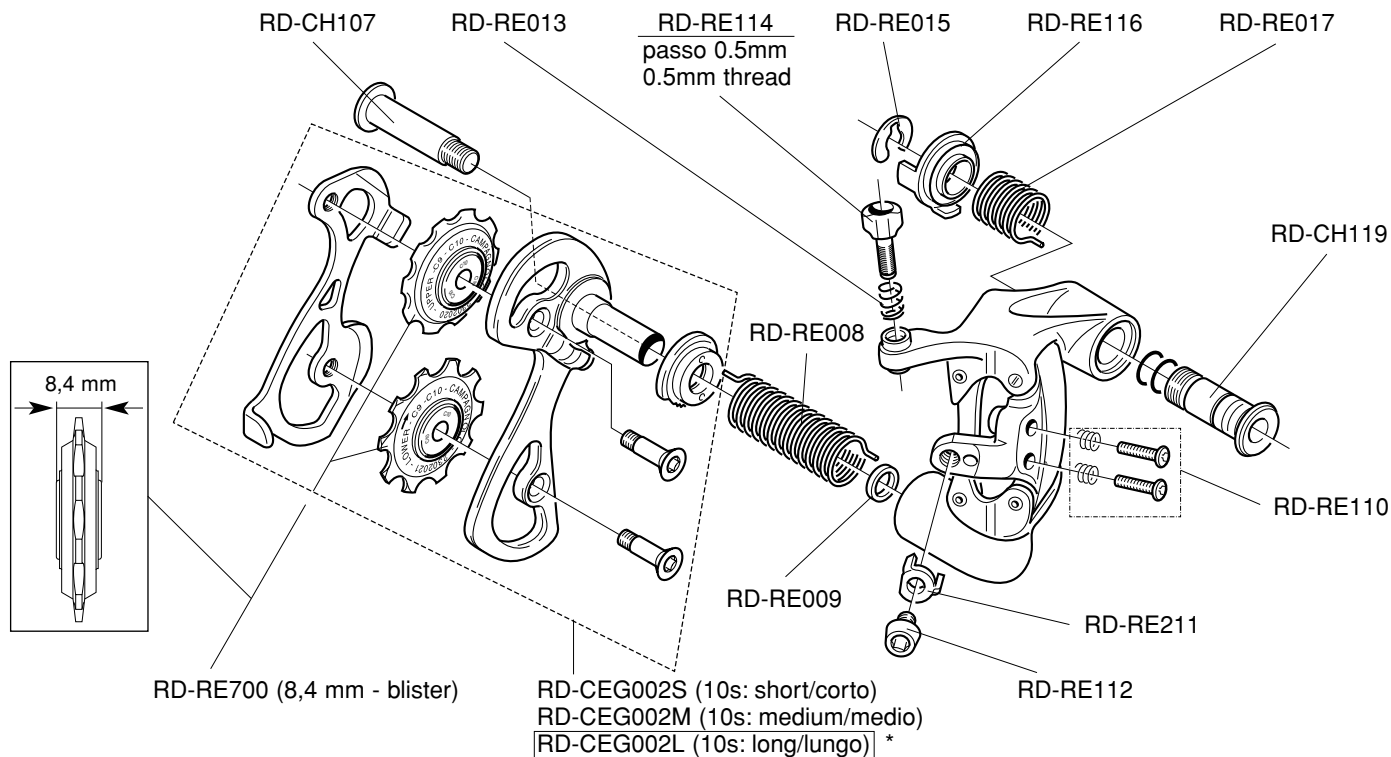

\* solo per RD4-CEGXL - non compatibile con RD4-CEGXS e RD4-CEGXM

\* only for RD4-CEGXL - not compatible with RD4-CEGXS and RD4-CEGXM



## VELOCE™ 10s

RD4-VLXS  
RD4-VLXM  
RD4-VLXL

## VELOCE™ 9s

RD02-VL209  
RD02-VL309  
RD4-VL9L

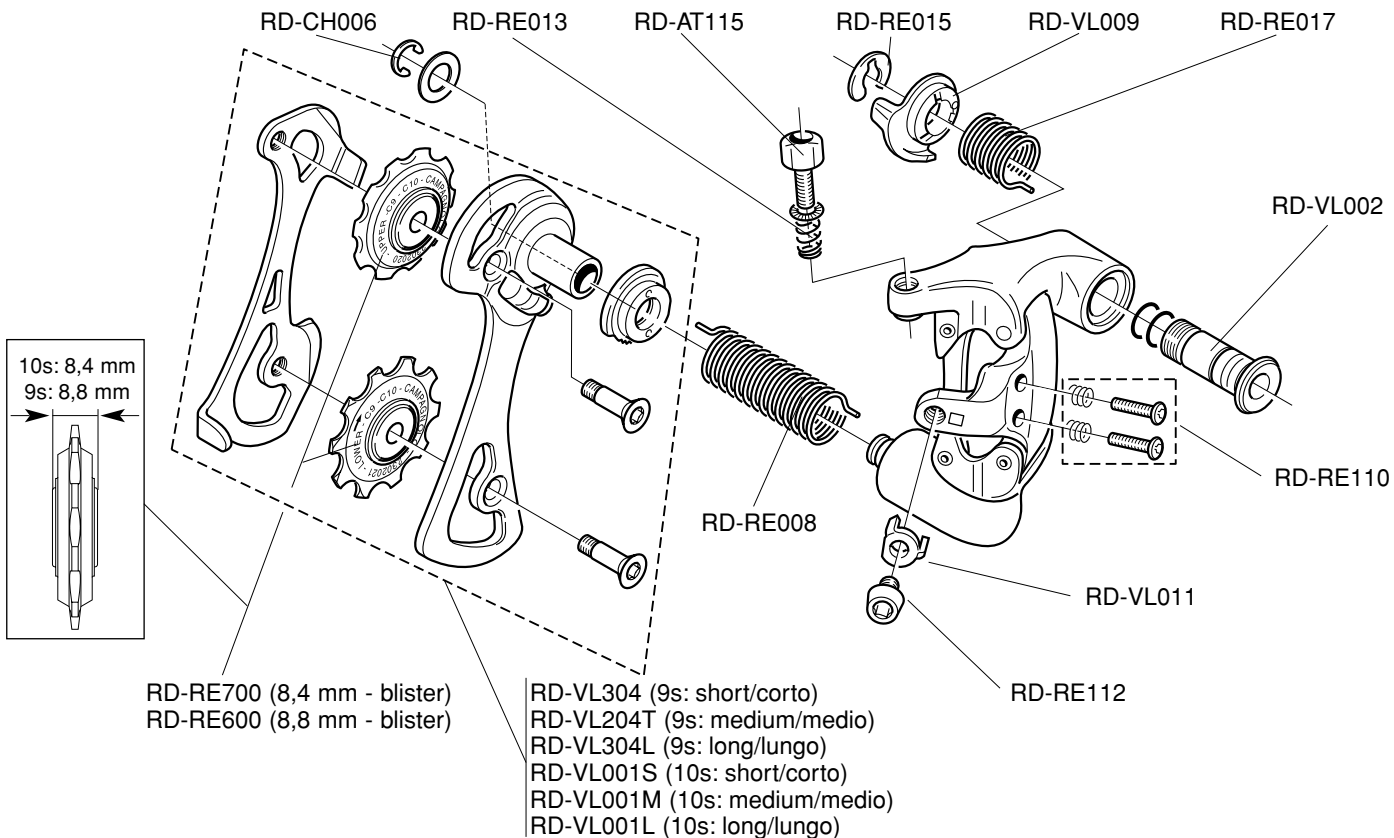

# MIRAGE™ BLACK 9s

RD4-MI9S

RD4-MI9M

RD4-MI9L

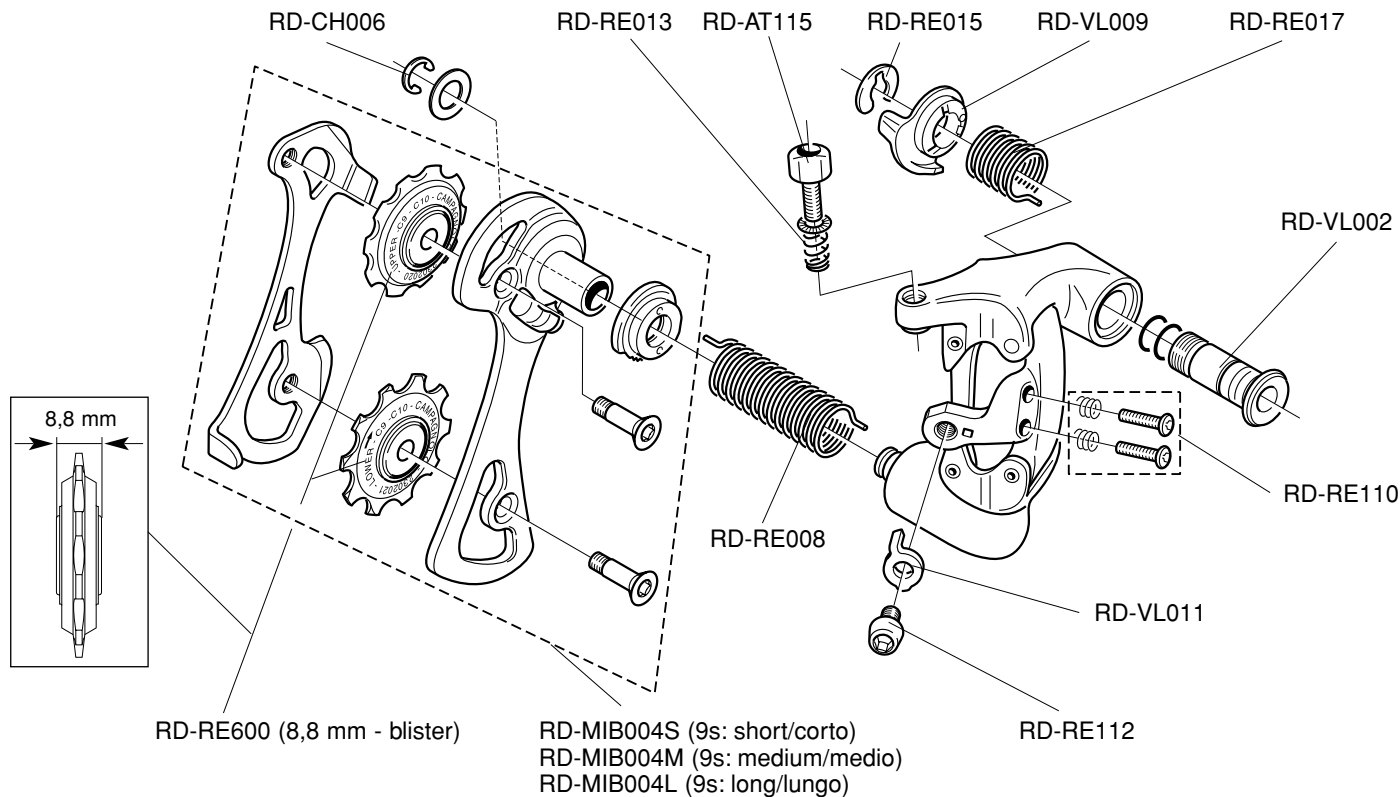

**XENON™ 9s**

**RD02-XE209**

**RD02-XE309**

**RD4-XE9L**

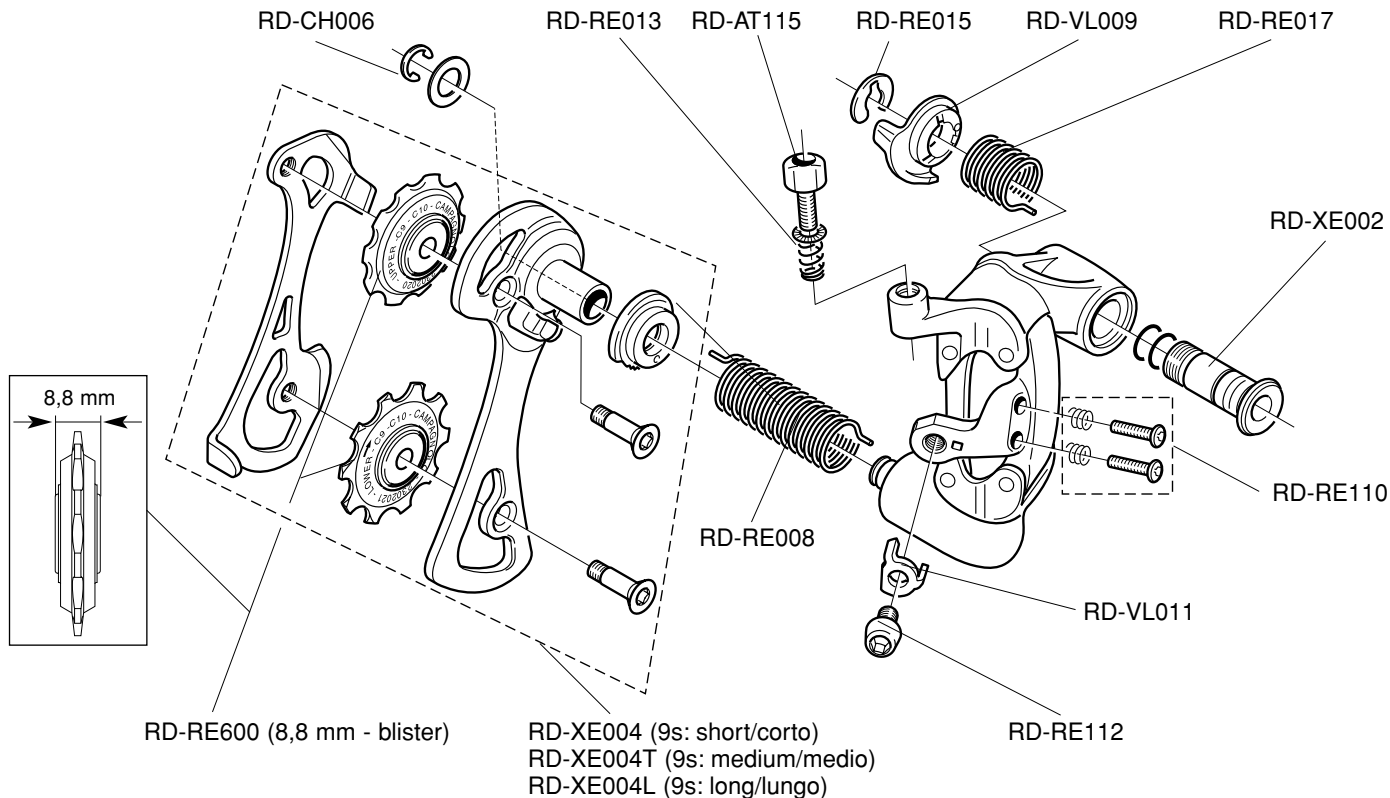

**RECORD™ 10s**  
**FD4-RE2..**

**9s compatible**

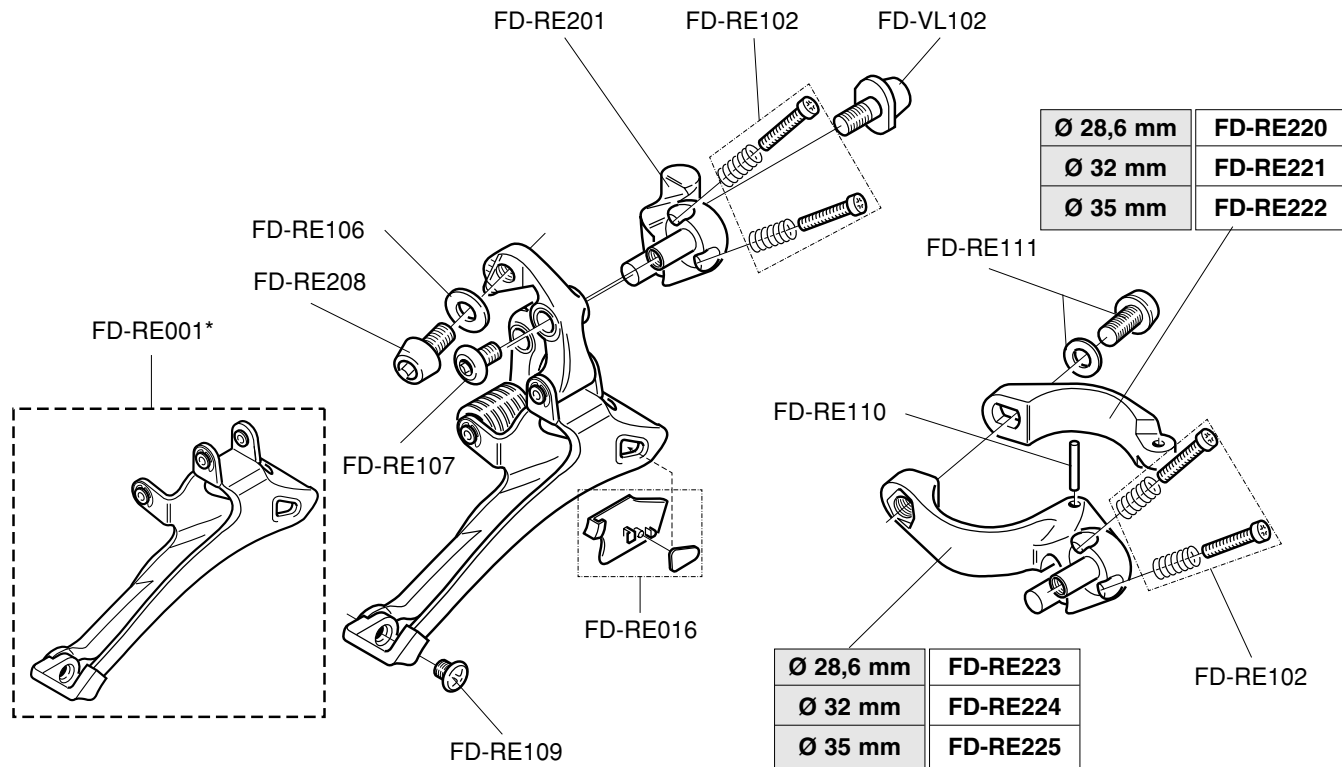

\* solo per deragliatore RECORD 2004 - non compatibile con gamma 2003 e precedenti

\* only for 2004 RECORD front derailleur - not compatible with 2003 range and previous

**CHORUS™ 10s**  
FD4-RE2..

**9s compatible**

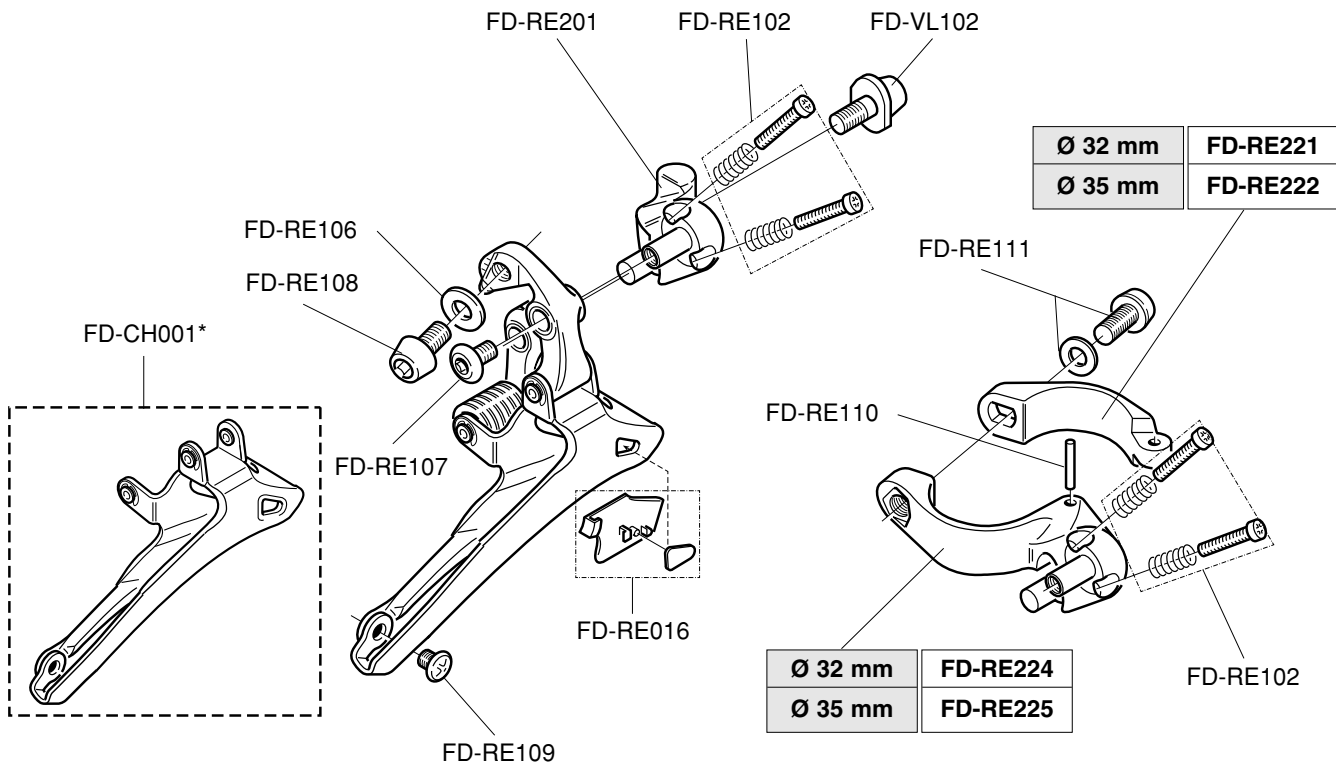

\* solo per deragliatore CHORUS 2004 - non compatibile con gamma 2003 e precedenti

\* only for 2004 CHORUS front derailleur - not compatible with 2003 range and previous

**RECORD™ TRIPLE 10s**

**FD4-RE3..**

**CHORUS™ TRIPLE 10s**

**FD4-CH3..**

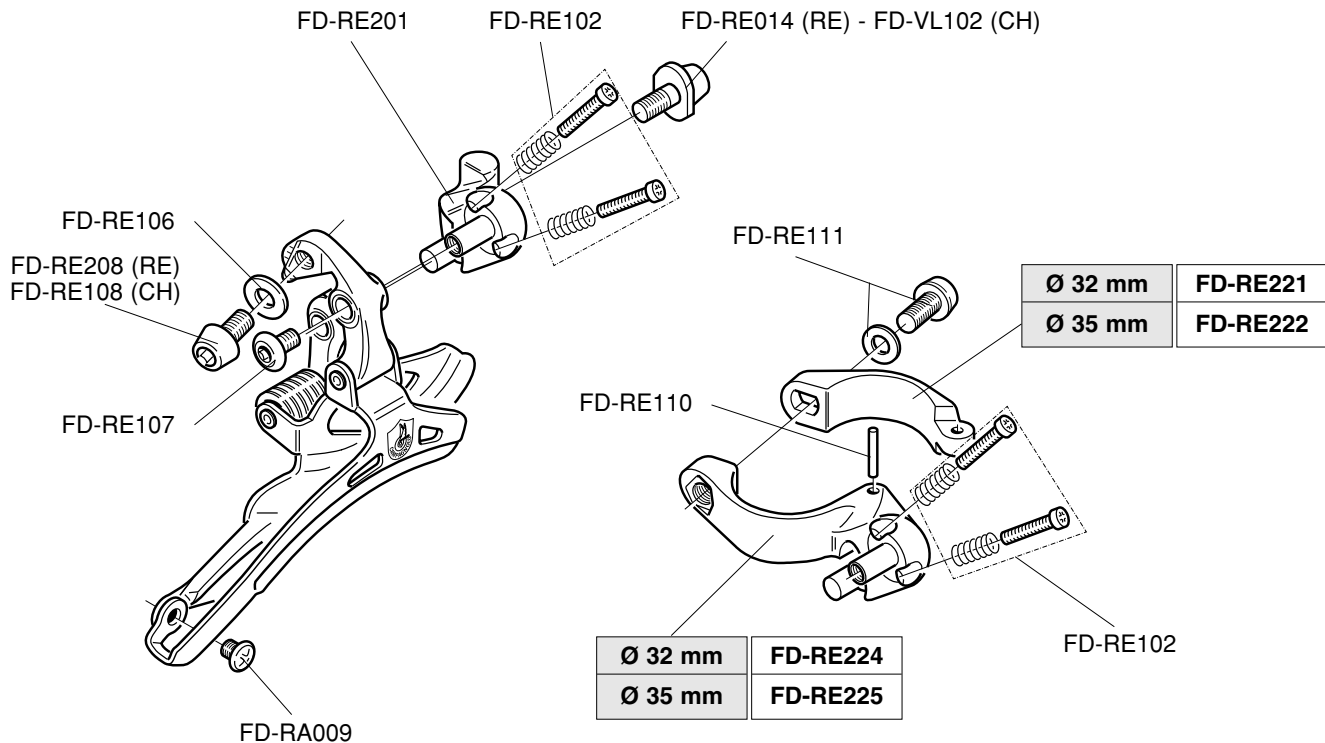

**CENTAUR™ 10s**  
**FD4-CE2..**  
**CENTAUR™ CENTURY GREY™ 10s**  
**FD4-CEG2...**

**9s compatible**

FD-CE001 (CENTAUR™)  
 FD-CEG001 (CENTAUR™ C-GREY™)

FD-RE102

FD-VL102

FD-RE106

FD-RE108

FD-RE107

FD-RE016

FD-RE109

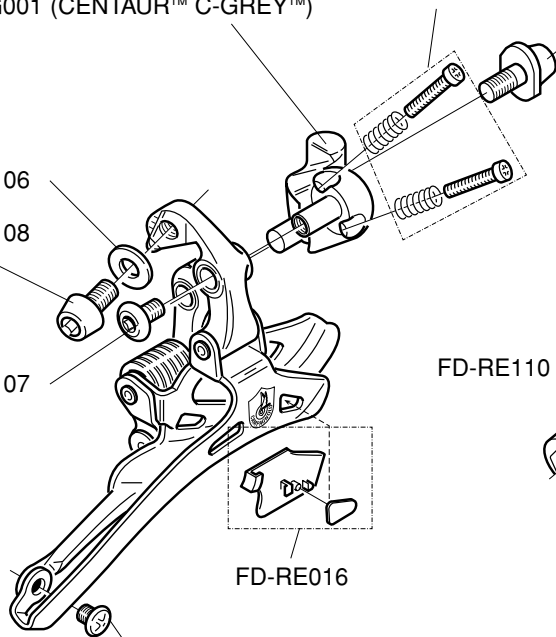

	CENTAUR™	C-GREY™
Ø 28,6 mm	FD-DA020	FD-CEG020
Ø 32 mm	FD-DA021	FD-CEG021
Ø 35 mm	FD-DA022	FD-CEG022

FD-RE111

FD-RE110

FD-RE102

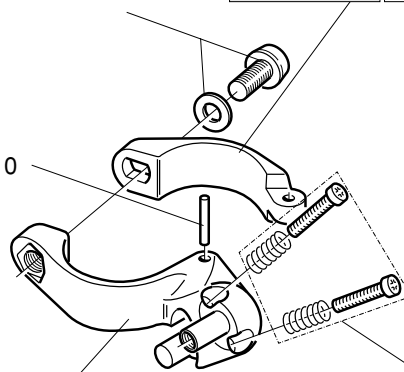

	CENTAUR™	C-GREY™
Ø 28,6 mm	FD-CE008	FD-CEG008
Ø 32 mm	FD-CE009	FD-CEG009
Ø 35 mm	FD-CE010	FD-CEG010

# CENTAUR™ TRIPLE 10s

FD4-CE3..

# CENTAUR™ CENTURY GREY™ TRIPLE 10s

FD4-CEG3..

9s compatible

FD-CE001 (CENTAUR™)

FD-CEG001 (CENTAUR™ C-GREY™)

FD-RE102

FD-VL102

FD-RE106

FD-RE108

FD-RE107

FD-RE111

FD-RE110

CENTAUR™

C-GREY™

Ø 32 mm

FD-DA021

FD-CEG021

Ø 35 mm

FD-DA022

FD-CEG022

FD-RA009

CENTAUR™

C-GREY™

Ø 32 mm

FD-CE009

FD-CEG009

Ø 35 mm

FD-CE010

FD-CEG010

FD-RE102



**VELOCE™ 10s**  
**FD4-VL2..**

**9s compatible**

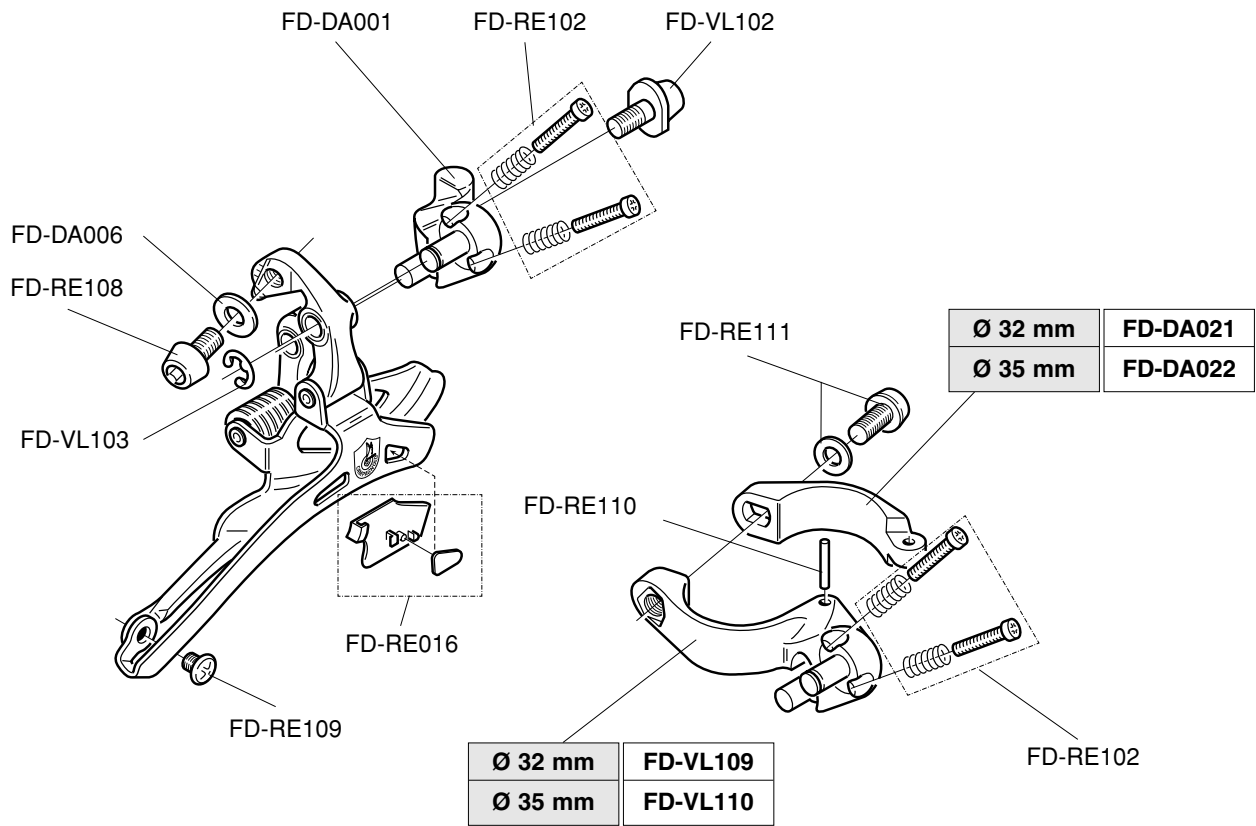

**VELOCE™  
TRIPLE 10s  
FD4-MI2..**

**MIRAGE™ BLACK 9s  
FD4-MIB2..  
MIRAGE™ TRIPLE BLACK 9s  
FD4-MIB3..**

**9s compatible**

FD-DA001 (VELOCE™)  
FD-MIB001 (MIRAGE™ BLACK)

FD-DA006

FD-RE108

FD-VL103

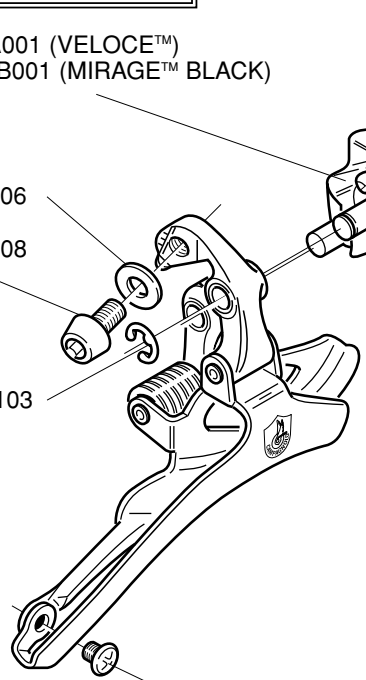

FD-RE109  
FD-RA009 (TRIPLE)

FD-RE102

FD-VL102

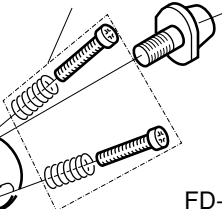

FD-RE111

FD-RE110

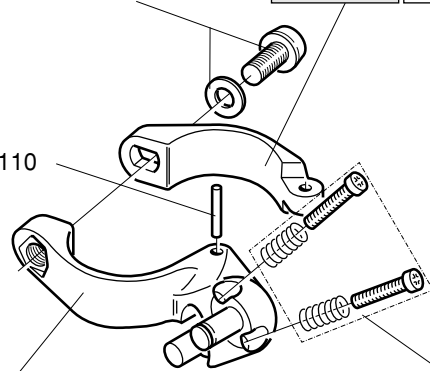

FD-RE102

	VELOCE™	MIR BLACK
Ø 28,6 mm	-	FD-MIB020
Ø 32 mm	FD-DA021	FD-MIB021
Ø 35 mm	FD-DA022	-

	VELOCE™	MIR BLACK
Ø 28,6 mm	-	FD-MIB008
Ø 32 mm	FD-VL109	FD-MIB009
Ø 35 mm	FD-VL110	-

**XENON™ 9s**  
**FD4-XE2..**  
**XENON™ TRIPLE 9s**  
**FD4-XE3..**

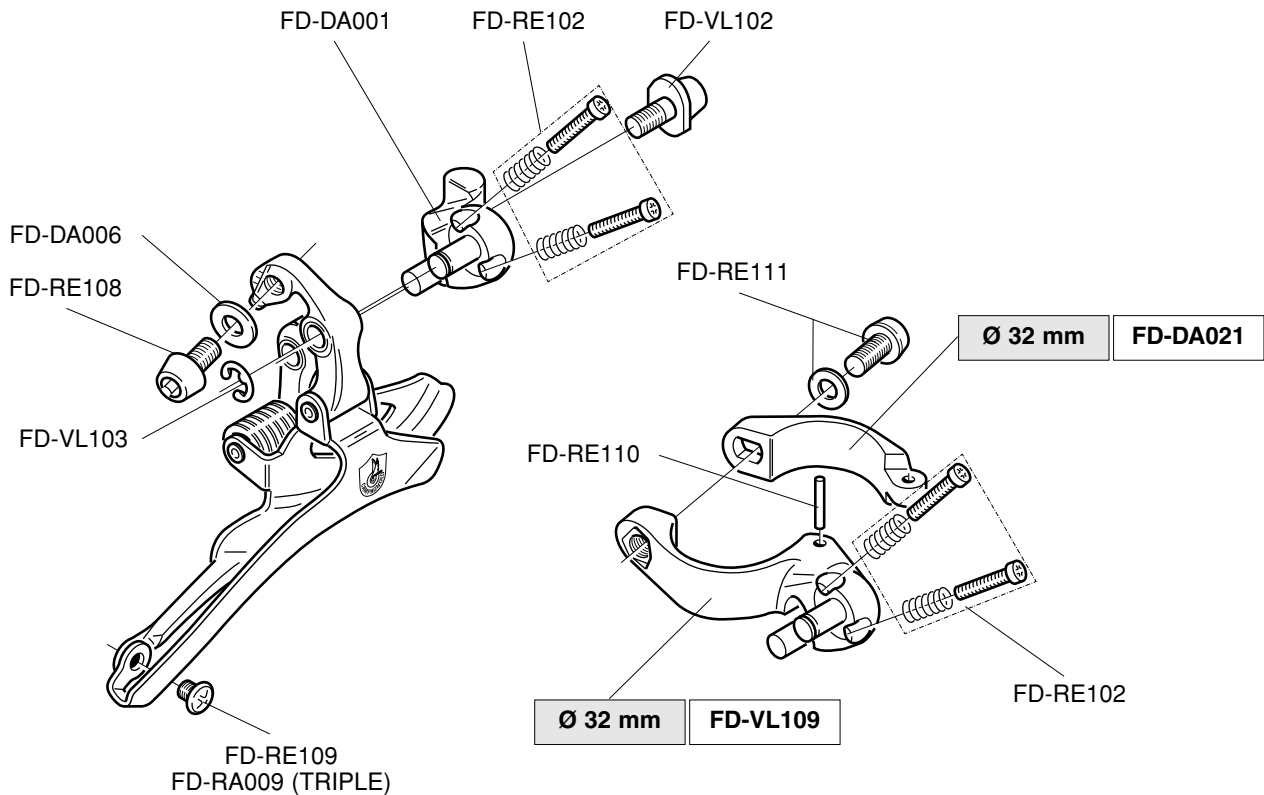

**RECORD™ 10s \***  
**EP4-REXC**

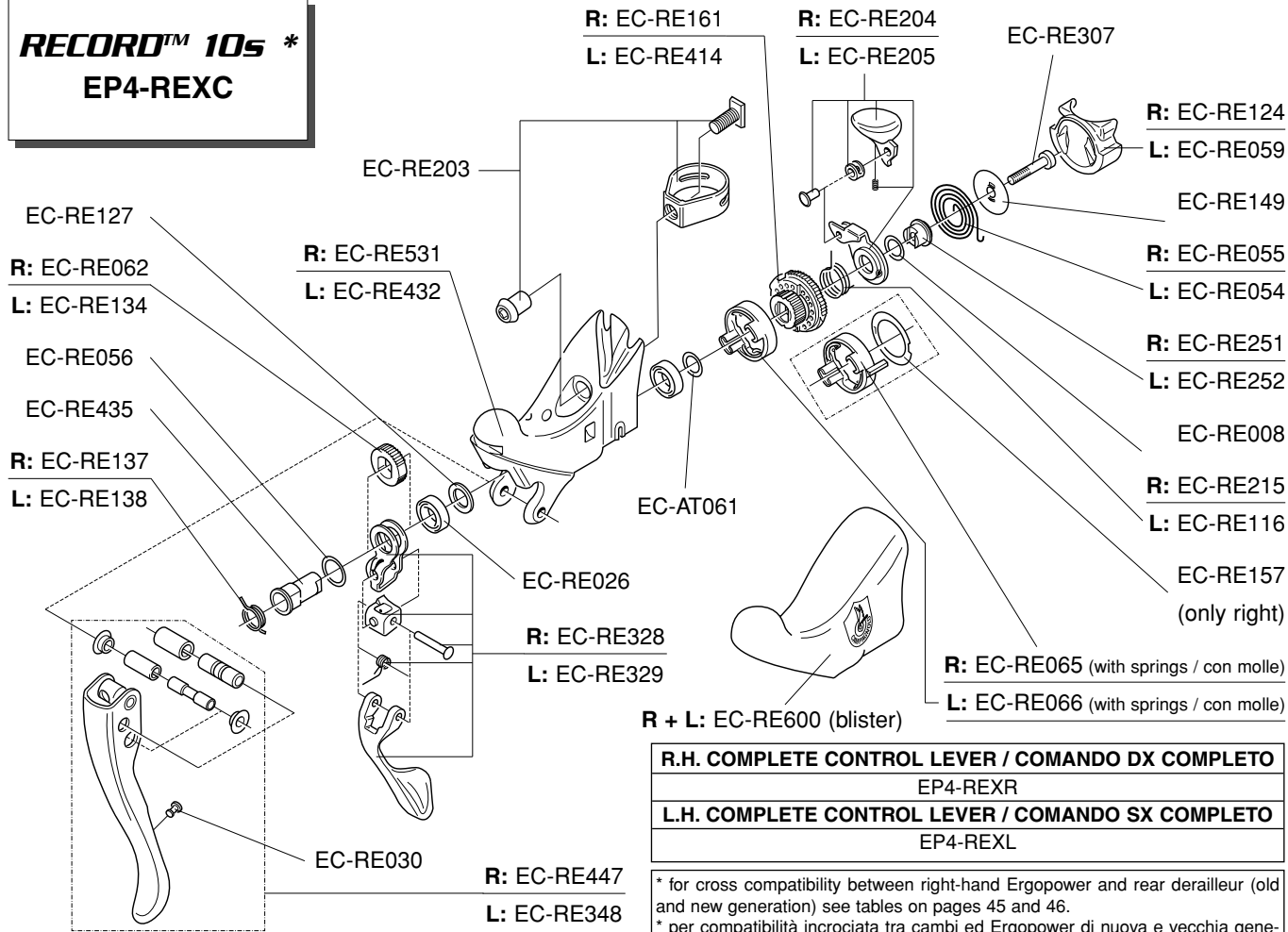

<b>R.H. COMPLETE CONTROL LEVER / COMANDO DX COMPLETO</b>
EP4-REXR
<b>L.H. COMPLETE CONTROL LEVER / COMANDO SX COMPLETO</b>
EP4-REXL

\* for cross compatibility between right-hand Ergopower and rear derailleurs (old and new generation) see tables on pages 45 and 46.  
 \* per compatibilità incrociata tra cambi ed Ergopower di nuova e vecchia generazione vedi tabelle alle pagg. 45 e 46.

**CHORUS™ 10s \***  
**EP4-CHXC**

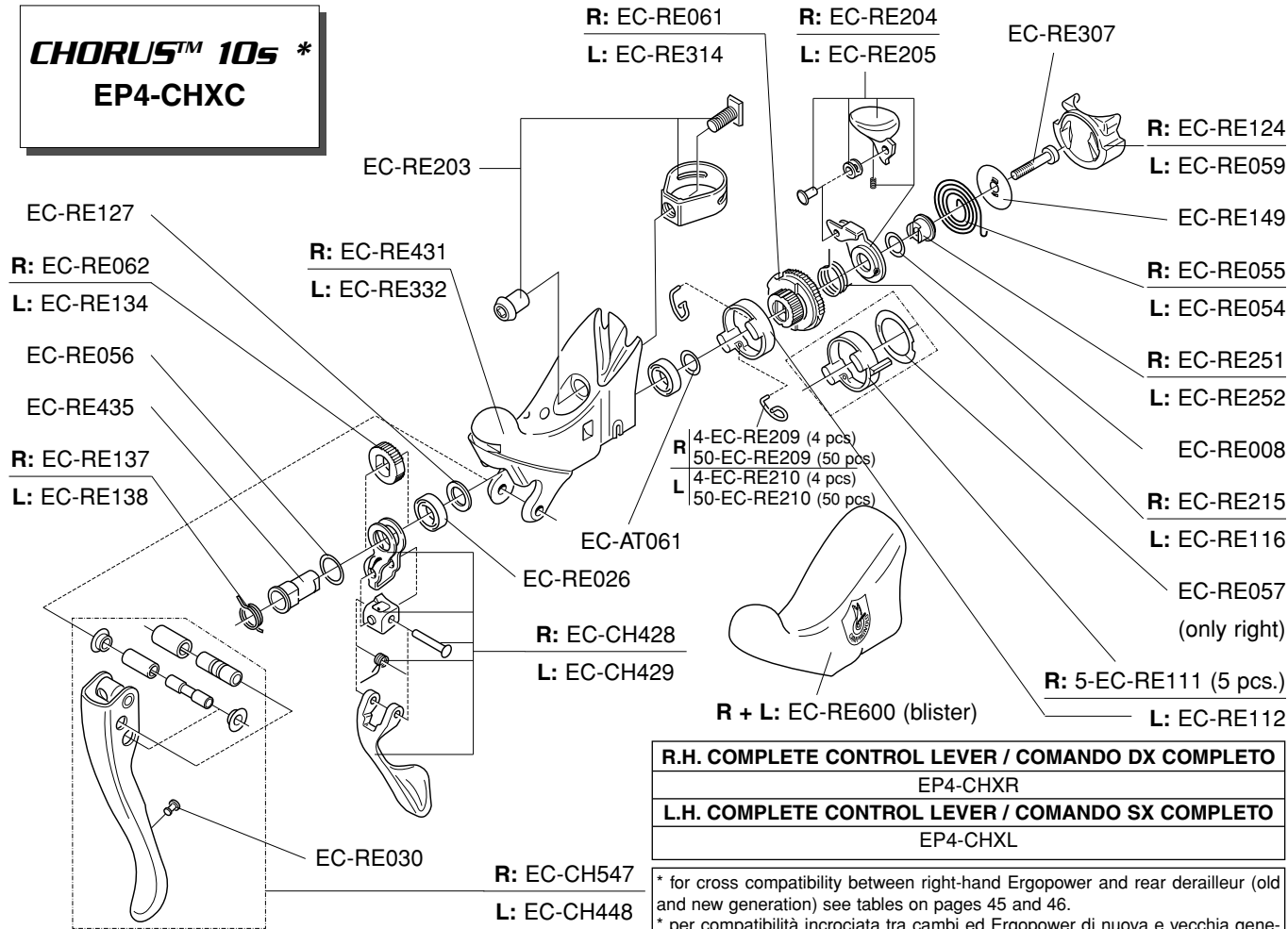

**R.H. COMPLETE CONTROL LEVER / COMANDO DX COMPLETO**

EP4-CHXR

**L.H. COMPLETE CONTROL LEVER / COMANDO SX COMPLETO**

EP4-CHXL

\* for cross compatibility between right-hand Ergopower and rear derailleur (old and new generation) see tables on pages 45 and 46.

\* per compatibilità incrociata tra cambi ed Ergopower di nuova e vecchia generazione vedi tabelle alle pagg. 45 e 46.

**CENTAUR™ 10s \***  
**EP03-CE10CG**  
**CENTAUR™ C-GREY 10s \***  
**EP4-CEGXC**

EC-RE127  
**R:** EC-RE062  
**L:** EC-RE134  
 EC-RE056  
 EC-VL036  
**R:** EC-RE137  
**L:** EC-RE138

CENTAUR™	
<b>R</b>	EC-DA231
<b>L</b>	EC-DA032
C-GREY	
<b>R</b>	EC-CEG031
<b>L</b>	EC-CEG032

CENTAUR™	
<b>R</b>	EC-CH328
<b>L</b>	EC-CH329
C-GREY	
<b>R</b>	EC-CEG028
<b>L</b>	EC-CEG029

	CENTAUR™	C-GREY
<b>R</b>	EC-CE247	EC-CEG047
<b>L</b>	EC-CE248	EC-CEG048

**R:** EC-RE061  
**L:** EC-RE314

**R:** EC-RE204  
**L:** EC-RE205

EC-RE307

**R:** EC-RE124  
**L:** EC-RE059

**R:** EC-RE055  
**L:** EC-RE054

**R:** EC-RE251  
**L:** EC-RE252

EC-RE008  
**R:** EC-RE215  
**L:** EC-RE116

EC-RE057  
 (only right)

**R:** 5-EC-RE111 (5 pcs.)

**L:** EC-RE112

**R** 4-EC-RE209 (4 pcs)  
 50-EC-RE209 (50 pcs)  
**L** 4-EC-RE210 (4 pcs)  
 50-EC-RE210 (50 pcs)

**R + L:** EC-RE600 (blister)

<b>R.H. COMPLETE CONTROL LEVER / COMANDO DX COMPLETO</b>
<b>CENTAUR™:</b> EP03-CE10R - <b>C-GREY:</b> EP4-CEGXR
<b>L.H. COMPLETE CONTROL LEVER / COMANDO SX COMPLETO</b>
<b>CENTAUR™:</b> EP03-CE10L - <b>C-GREY:</b> EP4-CEGXL

\* for cross compatibility between right-hand Ergopower and rear derailleur (old and new generation) see tables on pages 45 and 46.

\* per compatibilità incrociata tra cambi ed Ergopower di nuova e vecchia generazione vedi tabelle alle pagg. 45 e 46.

**VELOCE™ 10s \***  
**EP4-VLXC**  
**VELOCE™ 9s \***  
**EP03-VL09CG**

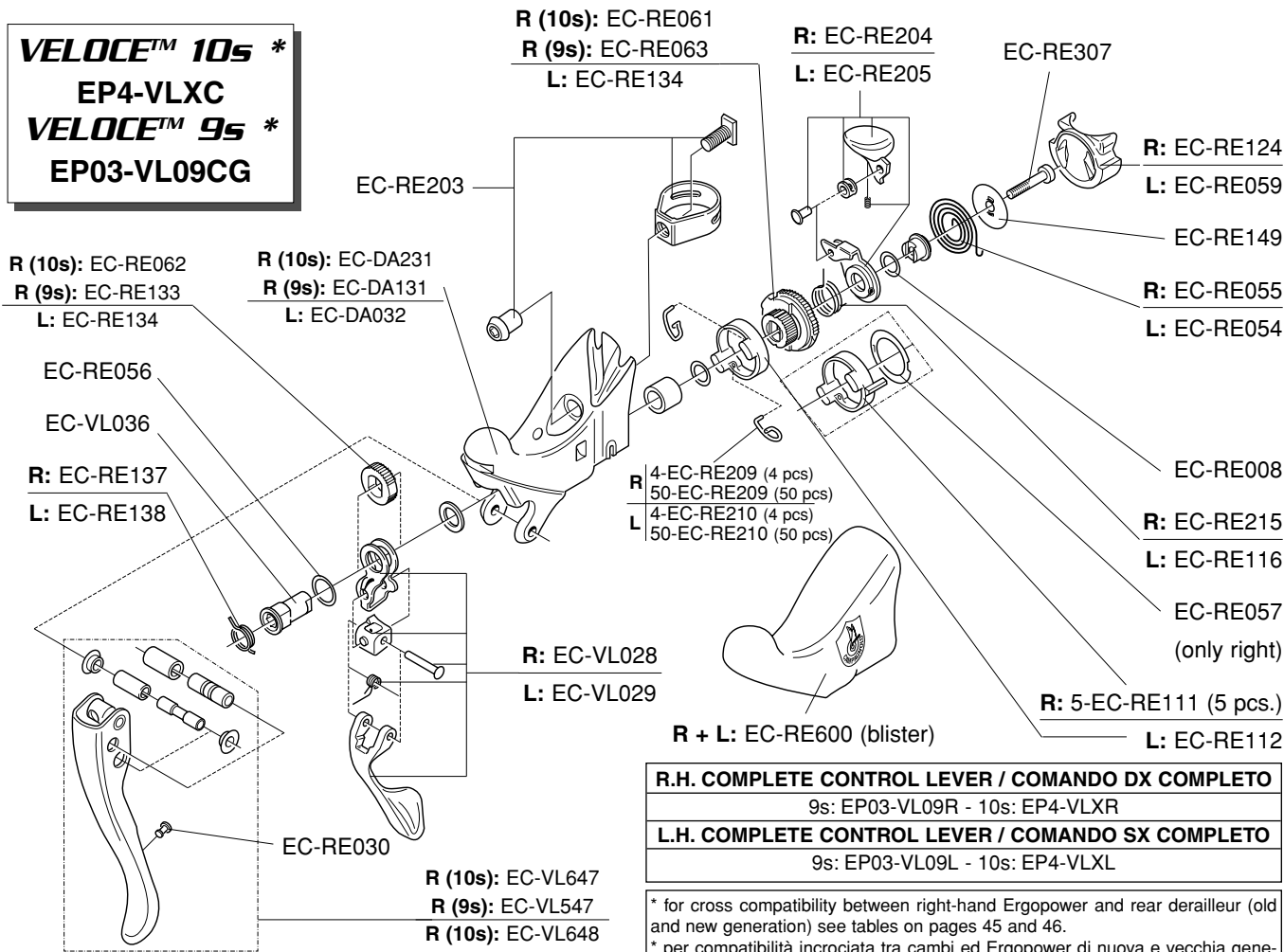

<b>R.H. COMPLETE CONTROL LEVER / COMANDO DX COMPLETO</b>
9s: EP03-VL09R - 10s: EP4-VLXR
<b>L.H. COMPLETE CONTROL LEVER / COMANDO SX COMPLETO</b>
9s: EP03-VL09L - 10s: EP4-VLXL

\* for cross compatibility between right-hand ErgoPower and rear derailleur (old and new generation) see tables on pages 45 and 46.  
 \* per compatibilità incrociata tra cambi ed ErgoPower di nuova e vecchia generazione vedi tabelle alle pagg. 45 e 46.

**MIRAGE™ 9s \***  
**EP01-MI09CG**

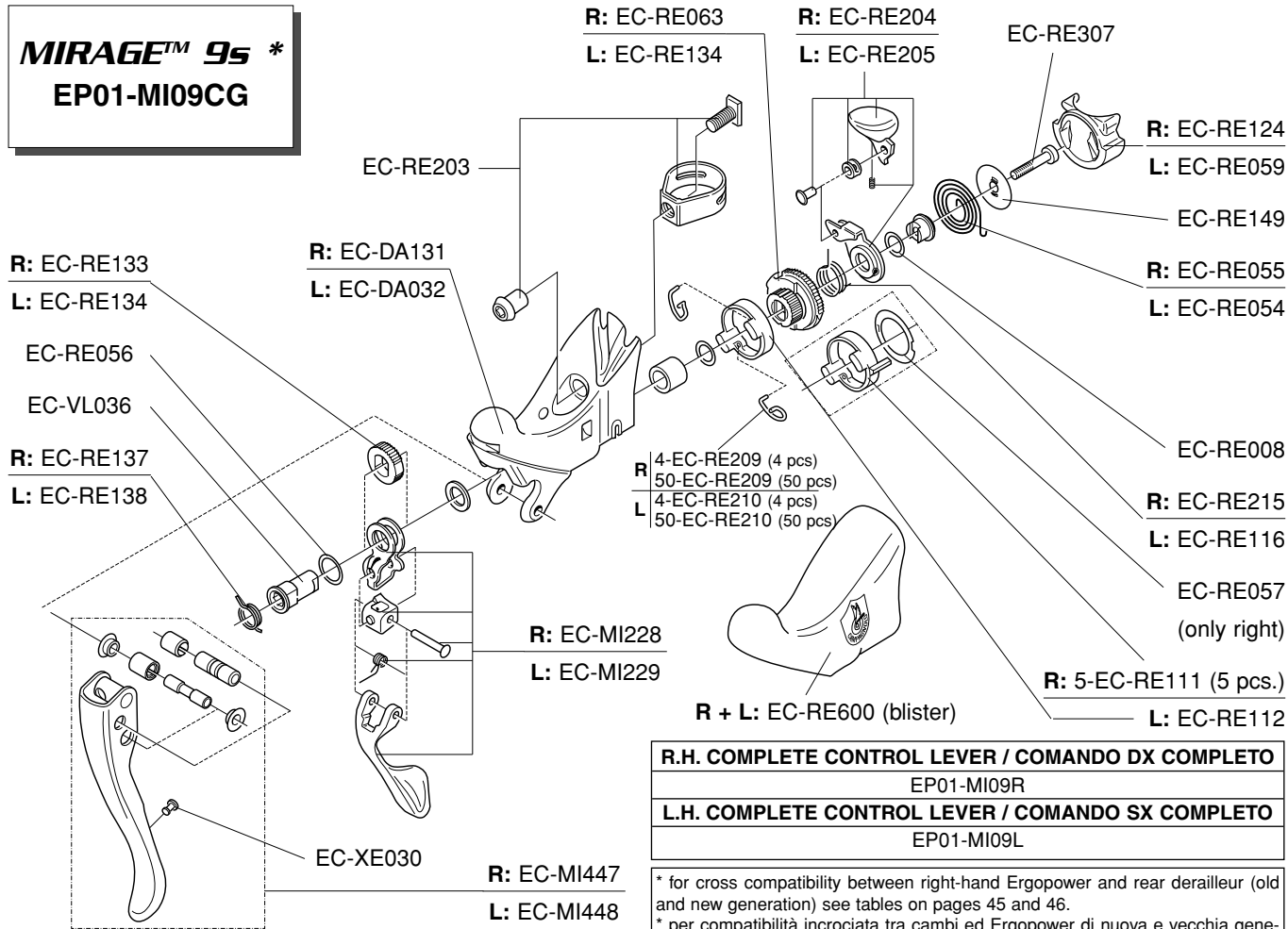

<b>R.H. COMPLETE CONTROL LEVER / COMANDO DX COMPLETO</b>
EP01-MI09R
<b>L.H. COMPLETE CONTROL LEVER / COMANDO SX COMPLETO</b>
EP01-MI09L

\* for cross compatibility between right-hand Ergopower and rear derailleur (old and new generation) see tables on pages 45 and 46.  
 \* per compatibilità incrociata tra cambi ed Ergopower di nuova e vecchia generazione vedi tabelle alle pagg. 45 e 46.



**XENON™ 9s \***  
**EP4-XE9C**

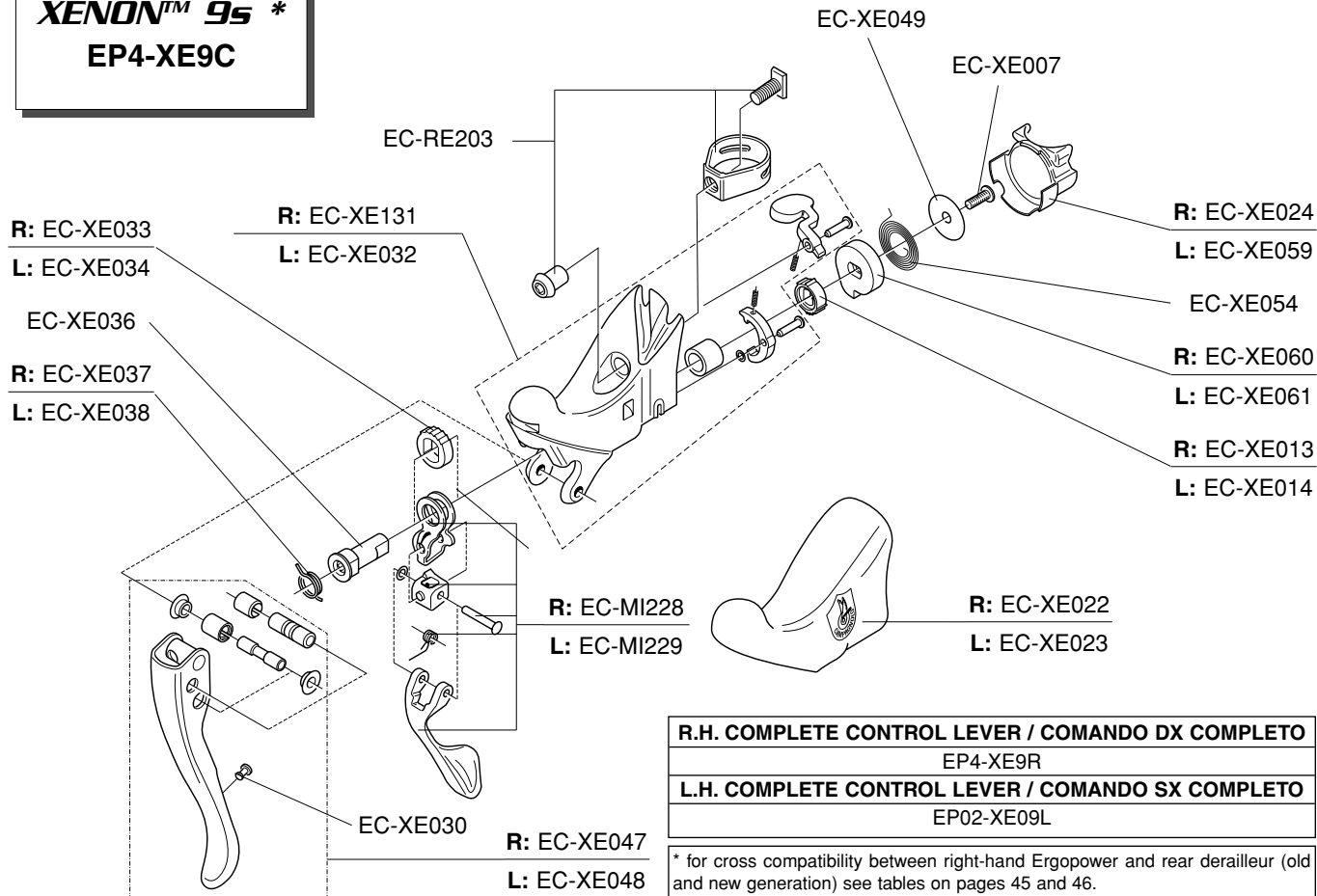

<b>R.H. COMPLETE CONTROL LEVER / COMANDO DX COMPLETO</b>
EP4-XE9R
<b>L.H. COMPLETE CONTROL LEVER / COMANDO SX COMPLETO</b>
EP02-XE09L

\* for cross compatibility between right-hand Ergopower and rear derailleur (old and new generation) see tables on pages 45 and 46.  
\* per compatibilità incrociata tra cambi ed Ergopower di nuova e vecchia generazione vedi tabelle alle pagg. 45 e 46.

**CROSS COMPATIBILITY BETWEEN RIGHT-HAND ERGOPOWERS AND REAR DERAILLEURS  
(old and new generation)**

**COMPATIBILITÀ INCROCIATA TRA ERGOPOWER DX E CAMBI  
(nuova e vecchia generazione)**

**ERGOPOWER**

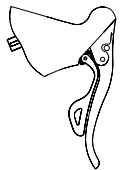
SPEED VELOCITÀ	YEAR ANNO	FEATURES CARATTERISTICHE		
8s	< 1998	“old style” (pointed) body / corpo a punta		<b>OLD STYLE</b>
9s	1997	“old style” (pointed) body / corpo a punta		
9s	1998	“new style” (rounded) body / corpo arrotondato		
9s	1999-2000	“new style” (rounded) body, ErgoBrain computer ready / corpo arrotondato, predisposizione ErgoBrain (pulsantino sul coprisupporto)		<b>NEW STYLE</b>
9s	2001-2002	“9 speed” mark, “new style” (rounded) body, ErgoBrain computer ready / logo “9 speed” sul corpo, corpo arrotondato, predisposizione ErgoBrain (pulsantino sul coprisupporto)		
10s	2000-2004	“10 speed” mark, “new style” (rounded) body, ErgoBrain computer ready / logo “10 speed” sul corpo, corpo arrotondato, predisposizione ErgoBrain (pulsantino sul coprisupporto)		

**REAR DERAILLEUR / CAMBIO**

SPEED VELOCITÀ	YEAR ANNO	FEATURES CARATTERISTICHE
8s	< 1998	adjusting system on the upper body / sistema di registrazione sul corpo superiore
9s	1997-2000	adjusting system on the upper body / sistema di registrazione sul corpo superiore
9s	2001-2004	adjusting system on the lower body / sistema di registrazione sul corpo inferiore



## CROSS COMPATIBILITY BETWEEN RIGHT-HAND ERGOPOWERS AND REAR DERAILLEURS (old and new generation)

### COMPATIBILITÀ INCROCIATA TRA ERGOPOWER DX E CAMBI (nuova e vecchia generazione)

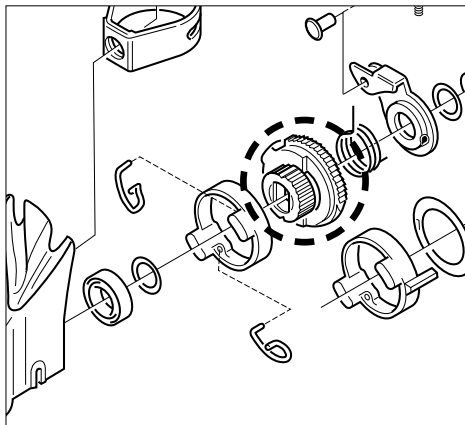

The codes in the table are referring to the indexing ratchet of the right-hand Ergopower (see the figure). To ensure the compatibility between replace the indexing ratchet with the one indicated in the table (referring to the rear derailleur / Ergopower combination).

I codici in tabella si riferiscono alla bussola dentata (evidenziata in figura) del comando dx Ergopower: per assicurare la compatibilità tra cambio ed Ergopower destro, va eventualmente sostituita la bussola dentata esistente con quella indicata in tabella (a seconda della combinazione cambio / Ergopower).

	9s 2001-2004 rear derailleur / cambio 9s 2001-2004	9s 1997-2000 rear derailleur / cambio 9s 1997-2000	8s rear derailleur / cambio 8s
Ergopower 8s	OK * (with C9 chain / con catena C9)	OK * (with C9 chain / con catena C9)	OK
Ergopower 9s 1997	EC-RE064	OK	NO
Ergopower 9s 1998	EC-RE064	OK	NO
Ergopower 9s 1999-2000	EC-RE063	OK	EC-RE060
Ergopower 9s 2001-2002	OK	EC-RE313	EC-RE060
Ergopower 10s 2000-2004	EC-RE063	EC-RE313	EC-RE060

# RECORD™-D

**BR4-RED “black”**  
**BR02-RED “silver”**

R: “black” BR-RE206 - “silver” BR-RE106

L: “black” BR-RE207 - “silver” BR-RE107

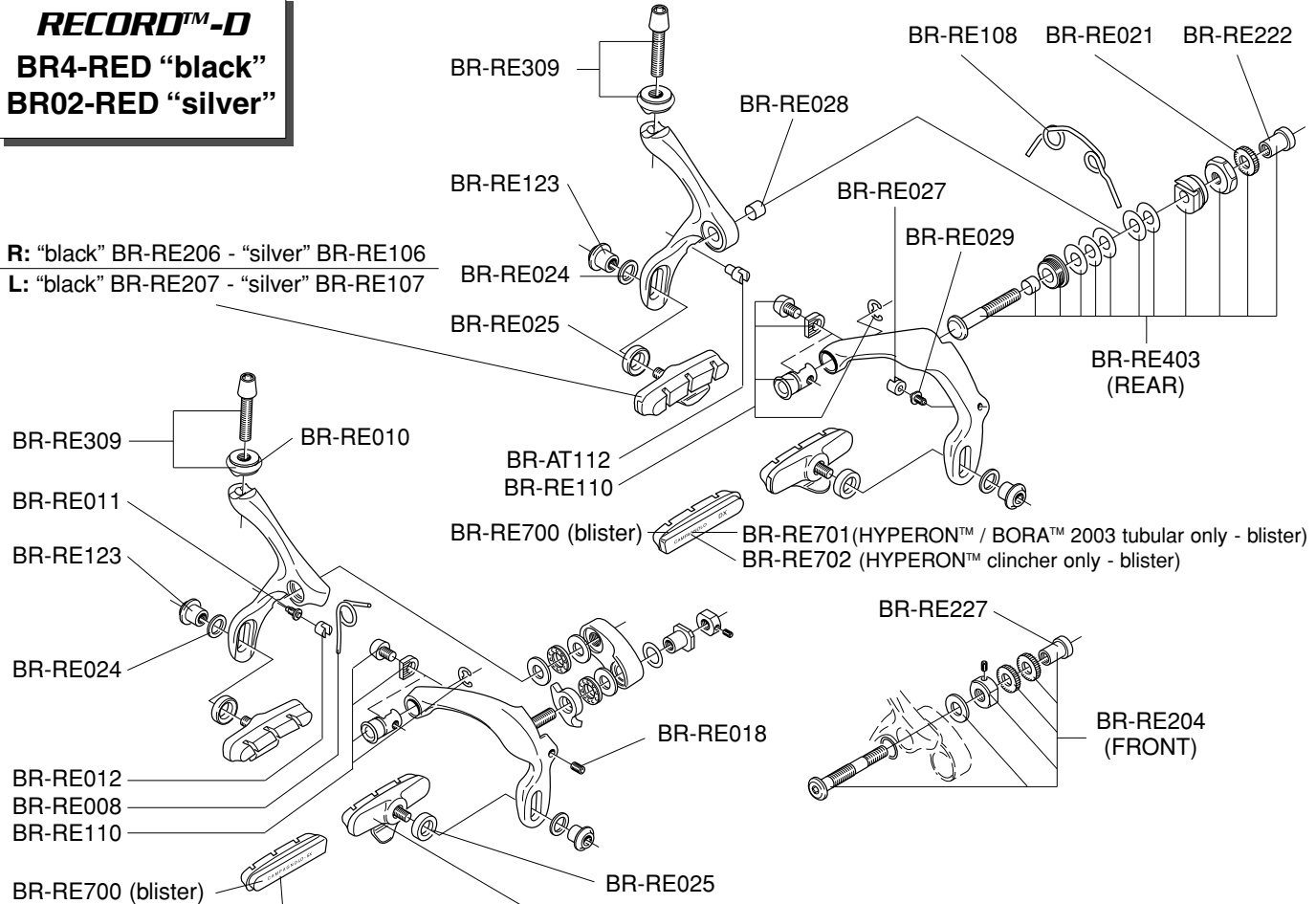

BR-RE701 (HYPERON™ / BORA™ 2003 tubular only - blister)  
BR-RE702 (HYPERON™ clincher only - blister)

R: “black” BR-RE206 - “silver” BR-RE106

L: “black” BR-RE207 - “silver” BR-RE107

## CHORUS™-D BR4-CHD

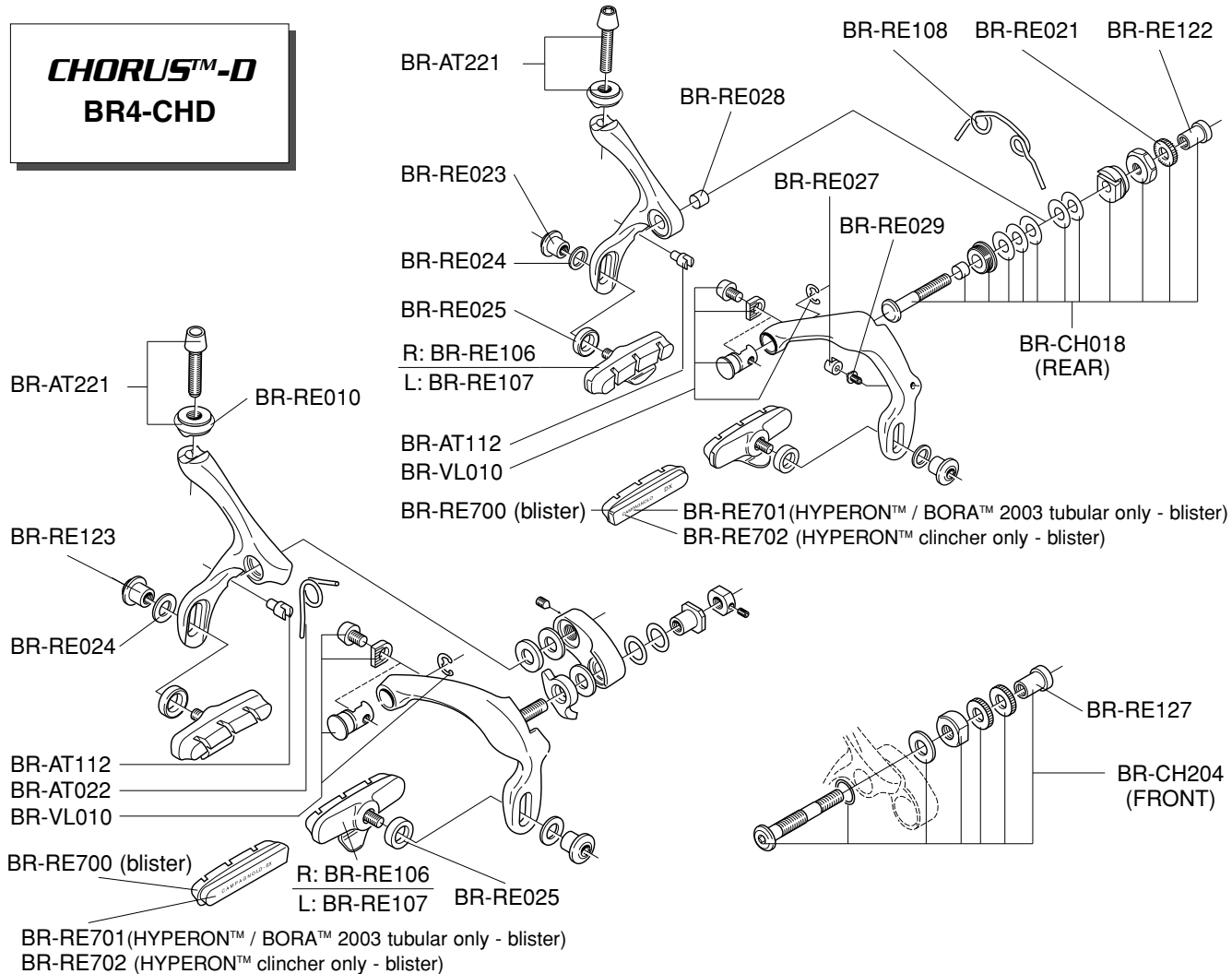

**CENTAUR™**  
**BR4-CE**  
**CENTAUR™ C-GREY**  
**BR4-CEG**

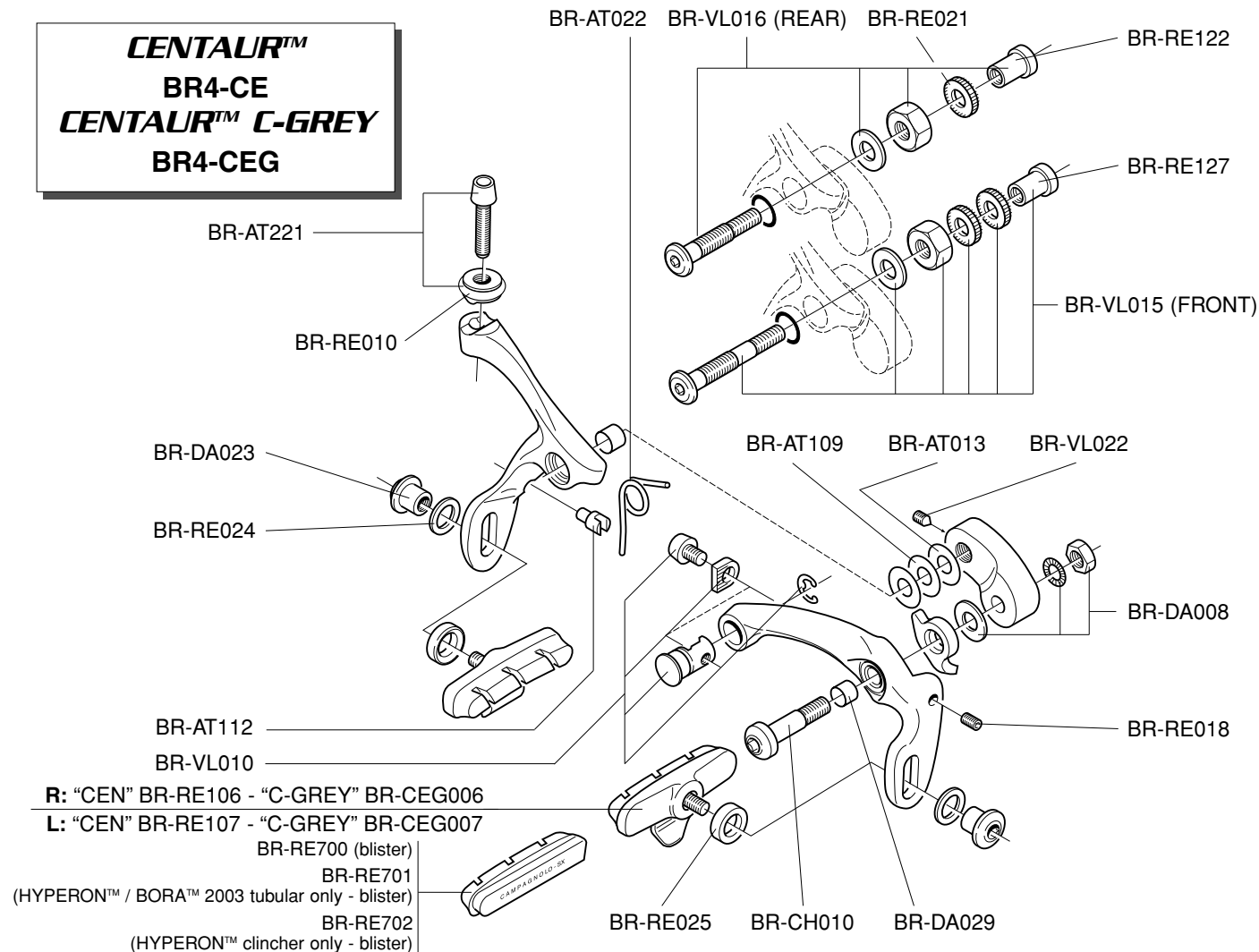

## VELOCE™ BR4-VL

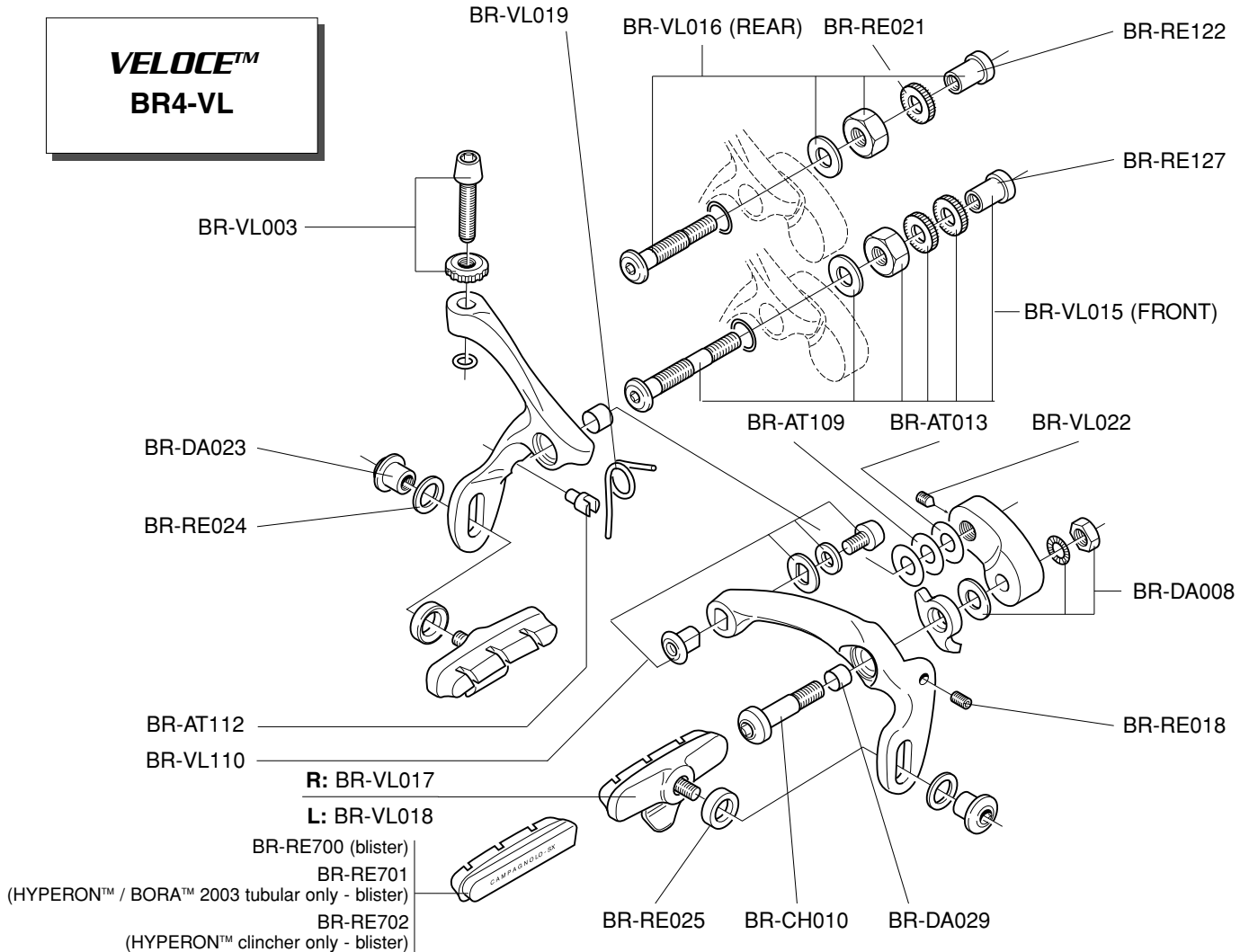

**MIRAGE™  
BLACK  
BR4-MIB**

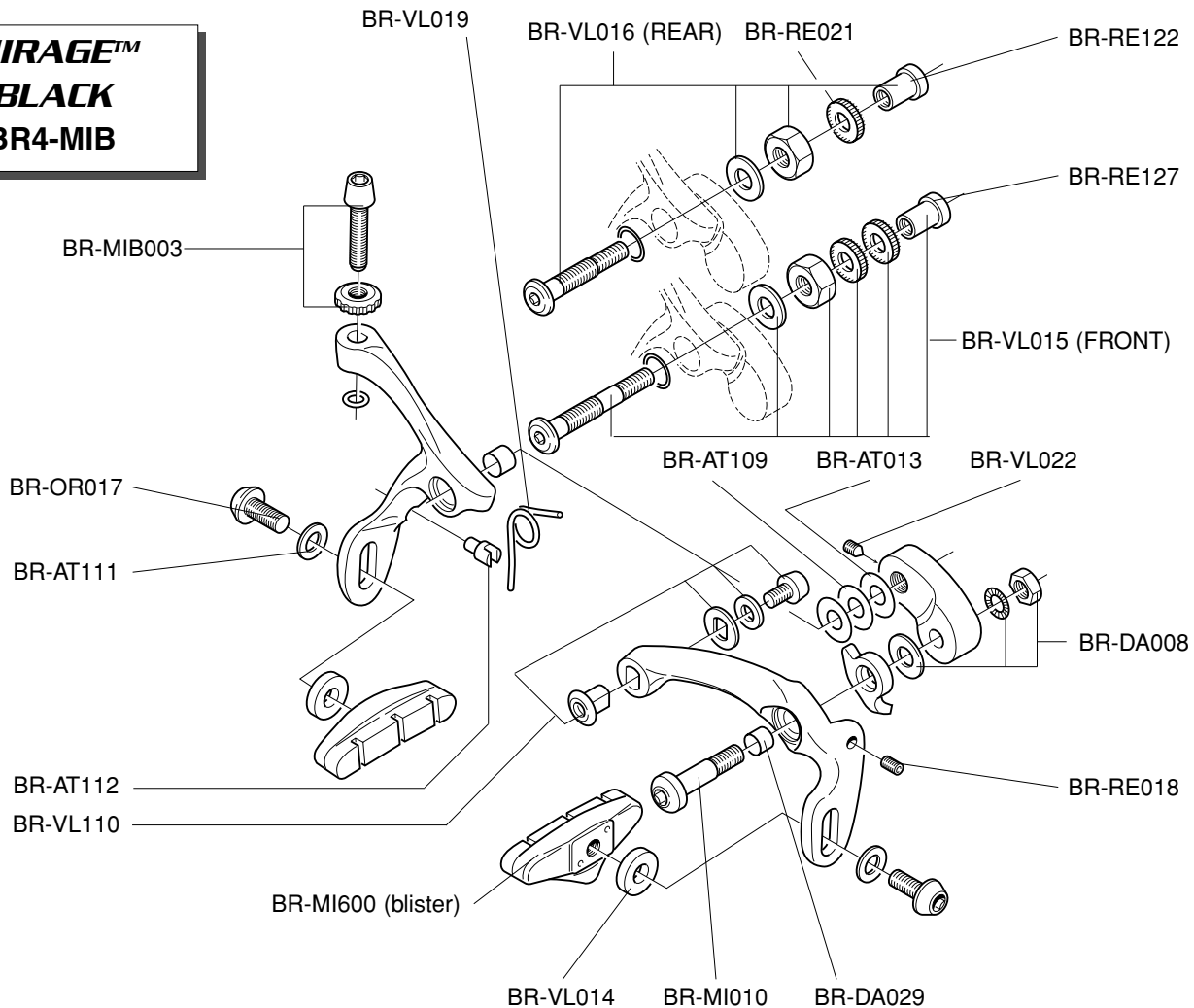



## **XENON™** **BR02-XE**

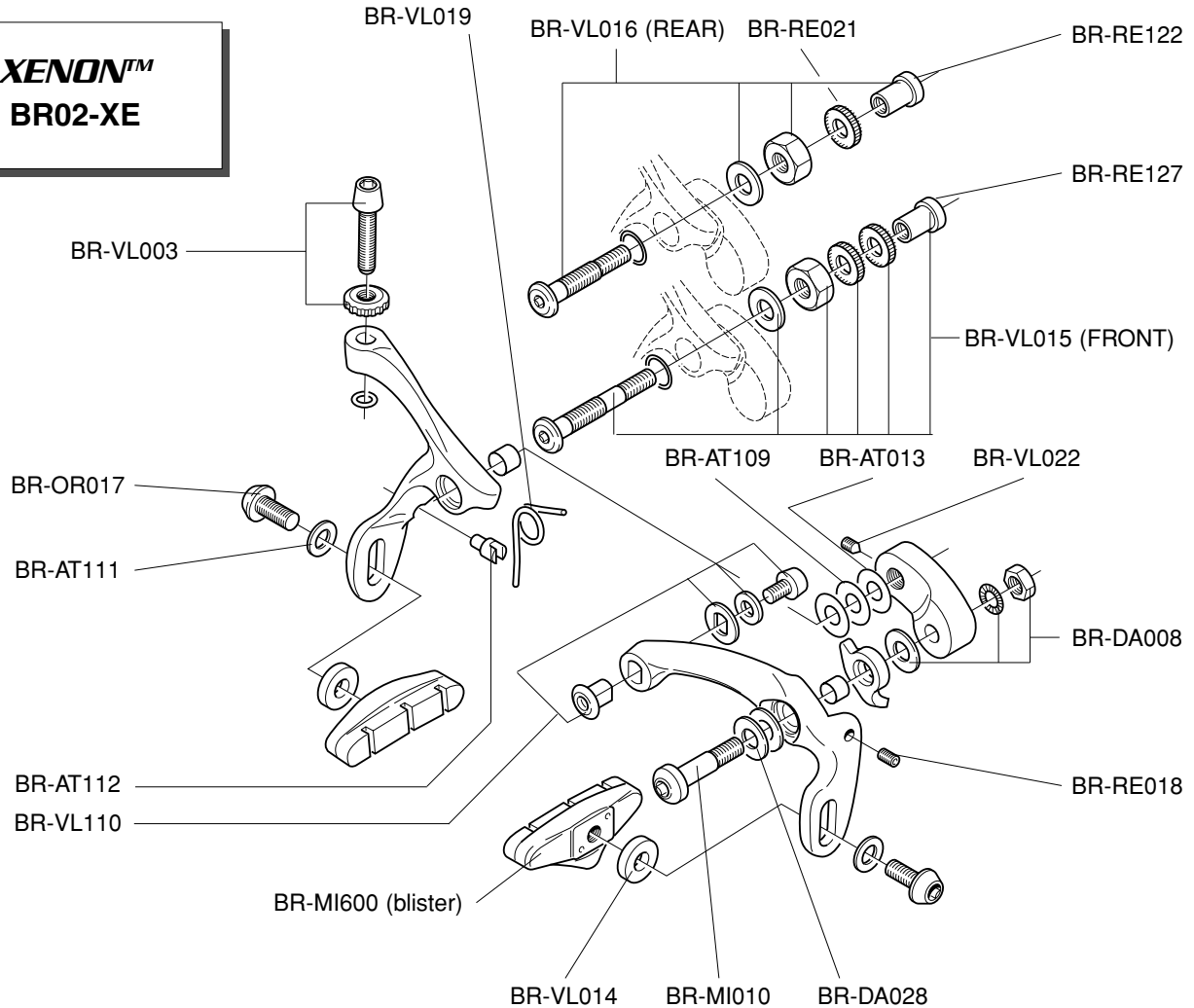

**BAR-END 10s**  
**SL00-BE10CG**

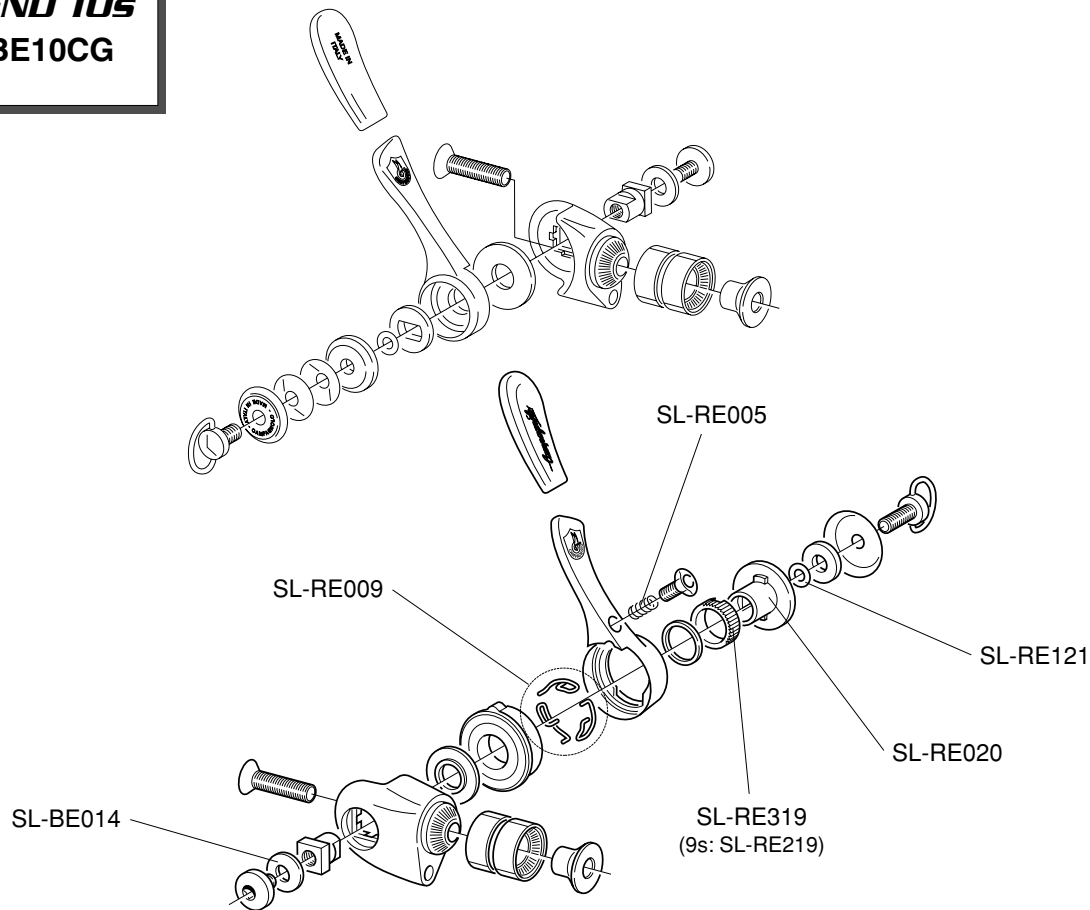

**RECORD™**  
*Carbon*  
**BL01-RECGC**

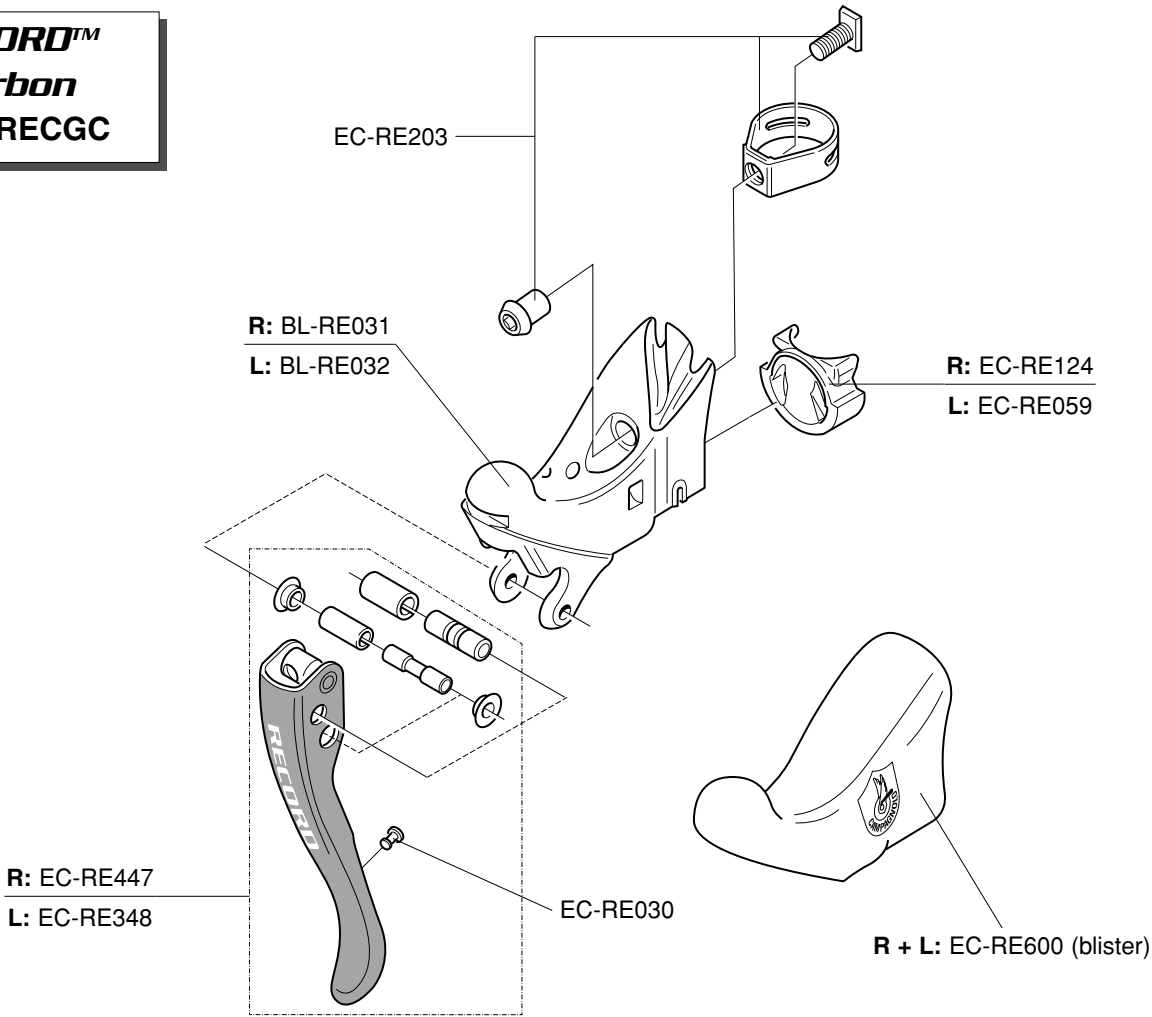

**RECORD™**

**BORA™ - EURUS™ - GHIBLI™**

**HYPERON™ - NEUTRON™**

front: QF-RE121

rear: QR-RE121

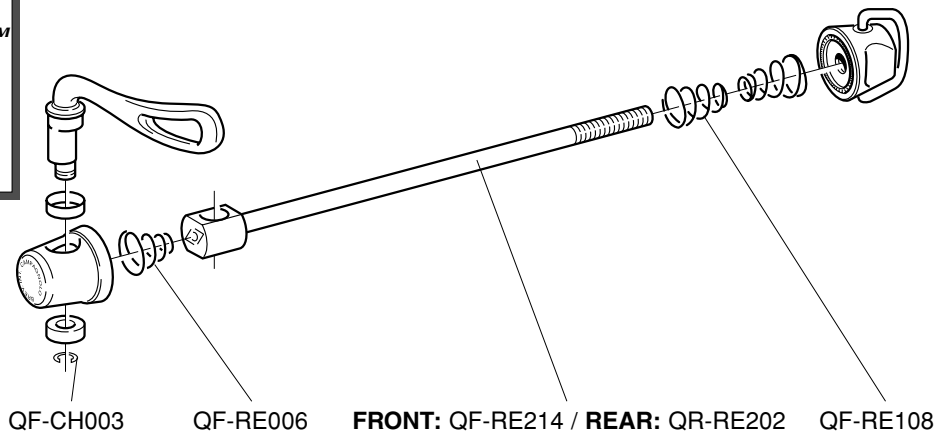

**CHORUS™**

front: QF-CH111

rear: QR-CH111

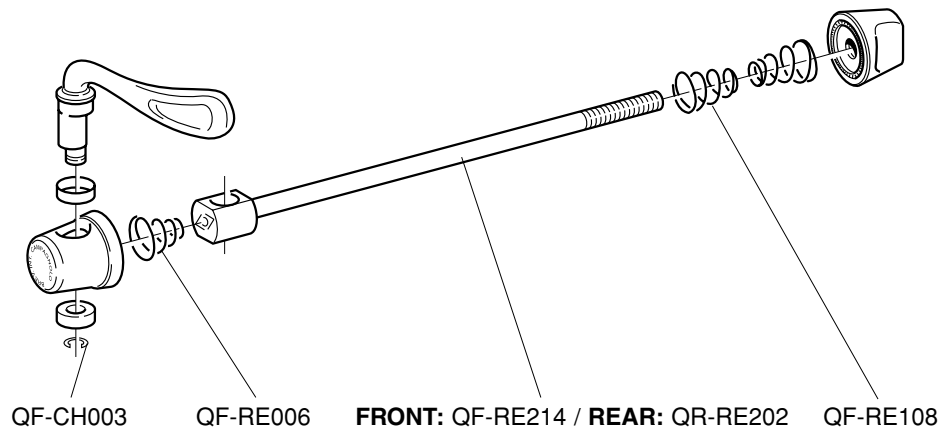

**CENTAUR™**  
**PROTON™**  
**ZONDA™**

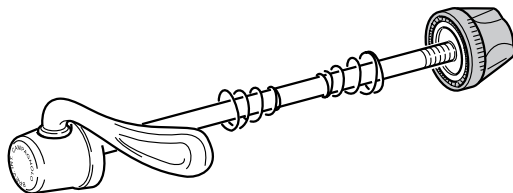

**FRONT: QF-AT101**  
**REAR: QR-AT101**

**VELOCE™**  
**SCIROCCO™**  
**VENTO™**

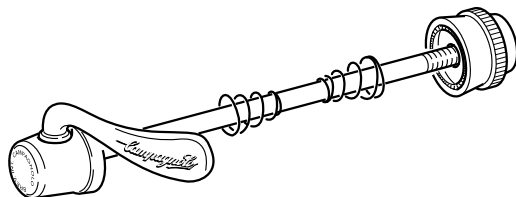

**FRONT: QF-AT101**  
**REAR: QR-AT101**

**RECORD™ HB02-RE..**  
**CHORUS™ HB02-CH..**  
**CENTAUR™ HB02-CE..**  
**CENTAUR™ CENTURY GREY™ HB4-CEG.**

RE/CH: HB-RE019  
 CE/CEG: HB-DA019

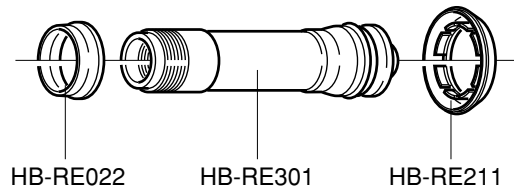
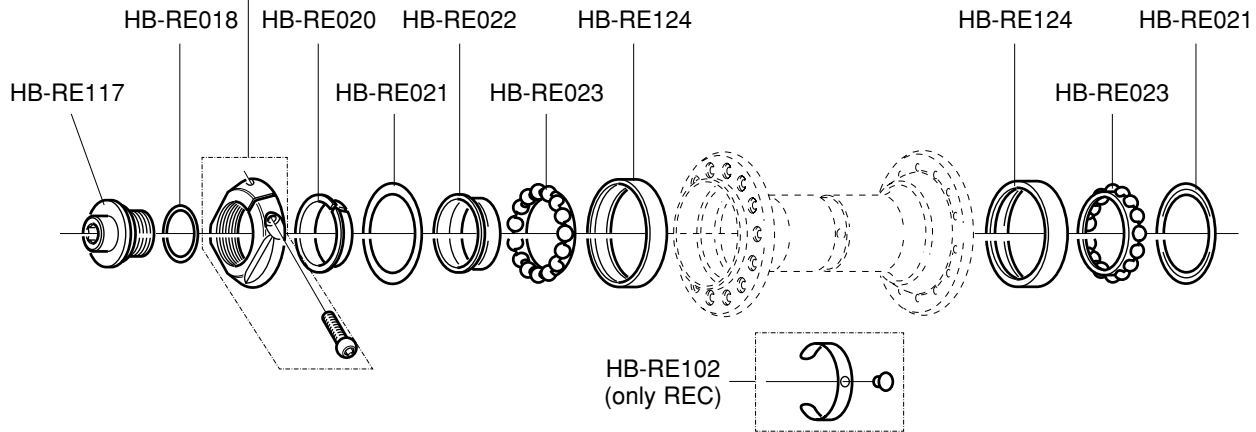

**RECORD™ 9s/10s FH02-RE..**  
**CHORUS™ 9s/10s FH02-CH..**  
**CENTAUR™ 9s/10s FH02-CE..**  
**CENTAUR™ CENTURY GREY™ 9s/10s FH4-CE.**

**RE:** FH-RE028  
**CH:** FH-CH025  
**CE/CEG:** HB-DA019

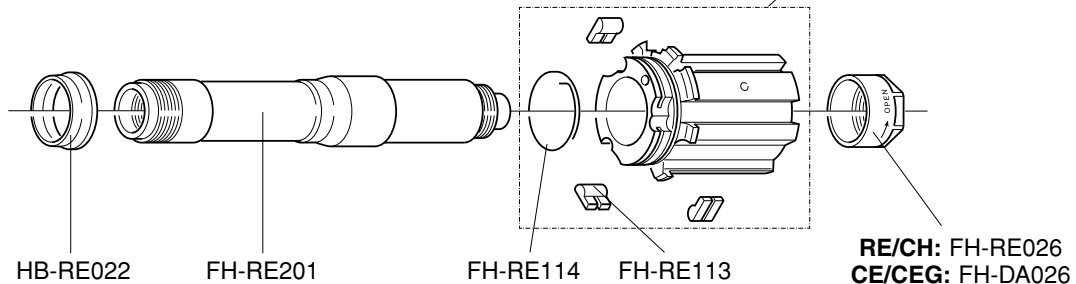
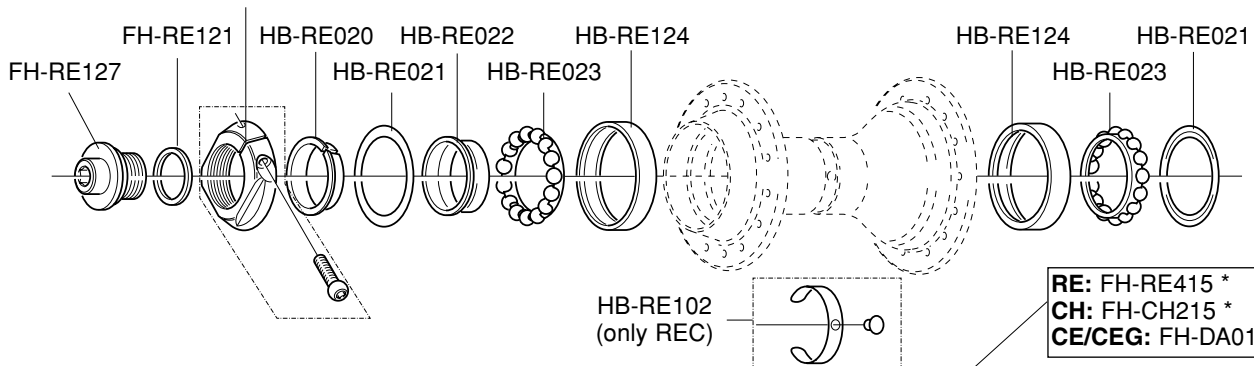

\* HG 8/9 type FW body / corpetto RL tipo HG 8/9: **WH-KX1** (RECORD™ type) **WH-KX2** (CHORUS™ type)

**VELOCE™ 9s/10s FH02-VL..**  
**MIRAGE™ 9s FH4-MIB.**

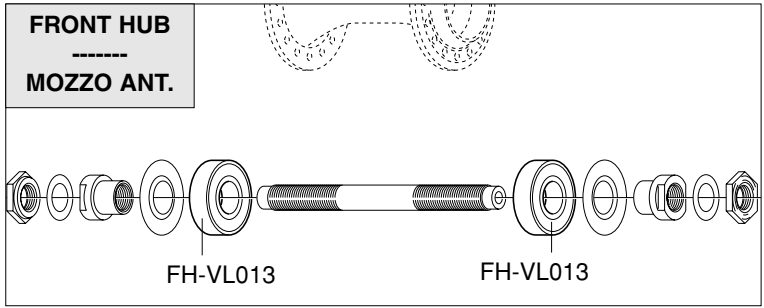

**VL:** FH-VL010  
**MI:** FH-MI110

FH-MI113

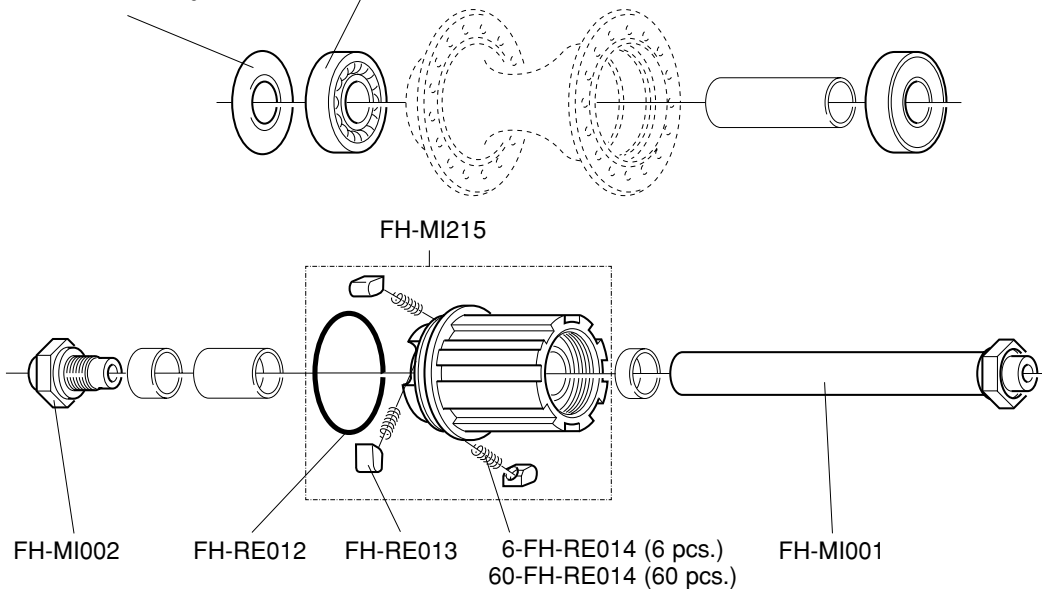



**RECORD™**  
**PISTA**  
**HB02-REPI..**

**FRONT HUB**

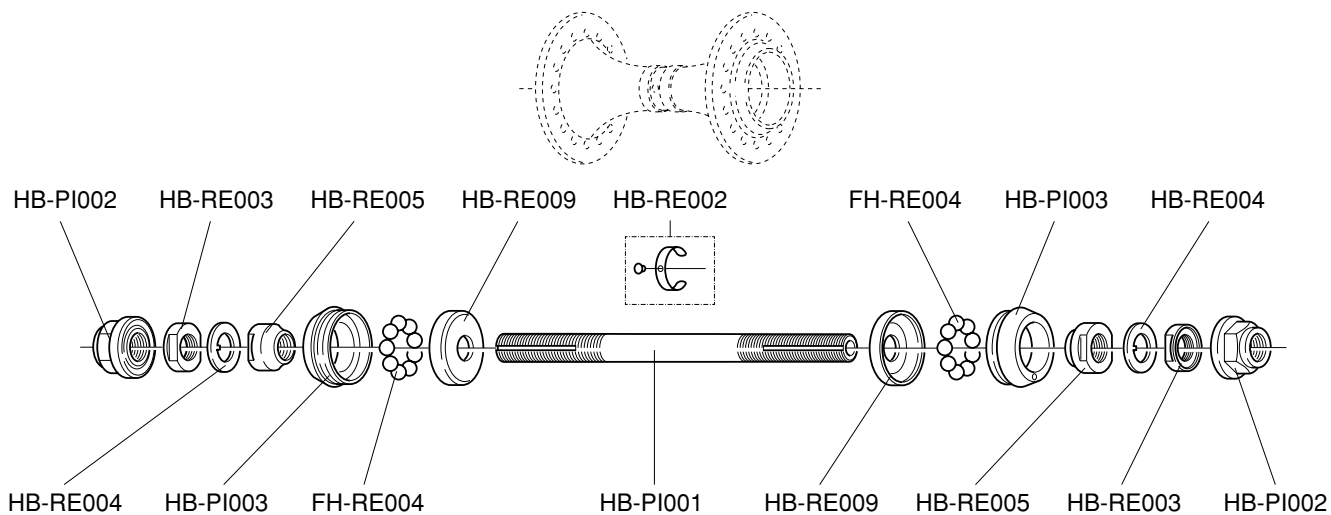

**RECORD™**  
**PISTA**  
**FH02-REPI..**

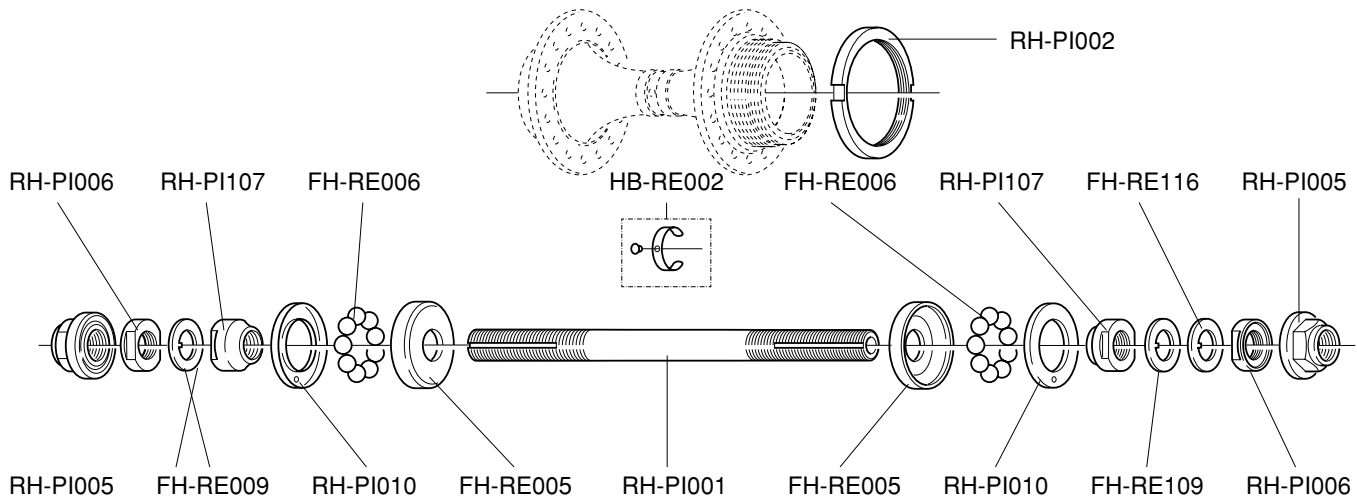

**ECROUS  
VERSCHLUSSRING**

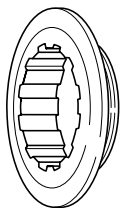

**GHIERE  
LOCKRINGS**

CODE CODICE	TYPE TIPO		RANGE GAMMA	HUB COMPATIBILITY COMPATIBILITÀ MOZZI
CS-401	<b>9s / 10s</b> "oversize" thread/fil.: 27 x 1	steel / acciaio	2000 e succ. <b>2000 and following</b>	<b>all groups / tutti i gruppi</b> all wheels / tutte le ruote
			<b>1999</b>	<b>™RECORD™ - CHORUS</b> all wheels / tutte le ruote
CS-501	<b>9s / 10s</b> "oversize" thread/fil.: 27 x 1	steel / acciaio (for Z. 11)	2000 e succ. <b>2000 and following</b>	<b>all groups / tutti i gruppi</b> all wheels / tutte le ruote
			<b>1999</b>	<b>RECORD™ - CHORUS™</b> all wheels / tutte le ruote
CS-101T	<b>9s / 10s</b> "oversize" thread/fil.: 27 x 1	titanium / titanio	2000 e succ. <b>2000 and following</b>	<b>all groups / tutti i gruppi</b> all wheels / tutte le ruote
			<b>1999</b>	<b>RECORD™ - CHORUS™</b> all wheels / tutte le ruote
CS-201	<b>9s</b> thread/fil.: 26 x 1	steel / acciaio	<b>1999</b>	<b>ATHENA - VELOCE™ - MIRAGE™</b>
			<b>1998 / 1997</b>	<b>9s groups / gruppi 9s</b> 9s wheels / ruote 9s
CS-301	<b>9s</b> thread/fil.: 26 x 1	steel / acciaio (for Z. 11)	<b>1999</b>	<b>ATHENA - VELOCE™ - MIRAGE™</b>
			<b>1998 / 1997</b>	<b>9s groups / gruppi 9s</b> 9s wheels / ruote 9s
CS-001T	<b>9s</b> thread/fil.: 26 x 1	titanium / titanio	<b>1999</b>	<b>ATHENA - VELOCE™ - MIRAGE™</b>
			<b>1998 / 1997</b>	<b>9s groups / gruppi 9s</b> 9s wheels / ruote 9s '97 8s aluminum FW body / corpetto RL in alluminio 8s '97
CS-001V	<b>8s</b> thread/fil.: 29 x 1	steel / acciaio	1999 e prec. <b>1999 and previous</b>	<b>all 8s hubs</b> (with steel FW body) <b>tutti i mozzi 8s</b> (con corpetto TL in acciaio)

**RECORD™**  
**UD 10s**  
**CSK00-RE10..**

**DISTANZIALI / SPACERS**

F = CS-601

G = CS-602

H = CS-603

I = CS-604

L = CS-605

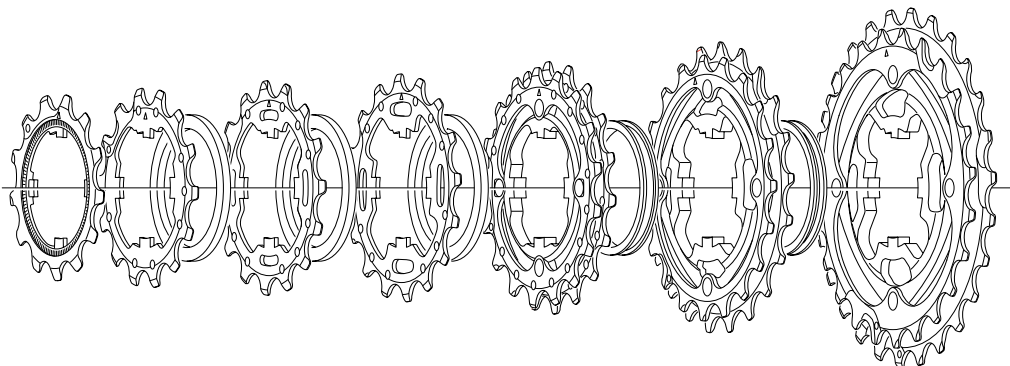

11 - 21	11A-1° 9S-011	12A-2° 10S-022		13A 10S-131	F	14A 10S-141	F	15A 10S-151	F	16A 10S-161	G	17A-18C* 10S-78CT	H	19C-21C* 10S-91CT
11 - 23	11A-1° 9S-011	12A-2° 10S-022		13A 10S-131	F	14A 10S-141	F	15A 10S-151	F	16A 10S-161	G	17A-19A* 10S-79AT	H	21A-23A* 10S-13AT
12 - 23	12A-1° 10S-032	13A 10S-131	F	14A 10S-141	F	15A 10S-151	F	16A 10S-161	I	17A 10S-171	G	18A-19A* 10S-89AT	H	21A-23A* 10S-113AT
12 - 25	12A-1° 10S-012	13A 10S-131	F	14A 10S-141	F	15A 10S-151	F	16A-17A* 10S-67A	I	19A-21A* 10S-91AT	L	23A-25A* 10S-35AT		
13 - 26	13A-1° 10S-013	14A 10S-141	F	15A 10S-151	F	16A 10S-161	F	17A-18C* 10S-78C	I	19C-21C* 10S-91CT	L	23C-26C* 10S-36CT		
13 - 29	13A-1° 10S-013	14A 10S-141	F	15A 10S-151	F	16A 10S-161	F	17A-19A* 10S-79A	I	21A-23A* 10S-13AT	L	26A-29A* 10S-69AT		

\* pre-assembled

**RECORD™ UD  
TITANIUM 10s  
CSK00-RE10..T**

**DISTANZIALI / SPACERS**

F = CS-601
G = CS-602
H = CS-603
I = CS-604
L = CS-605

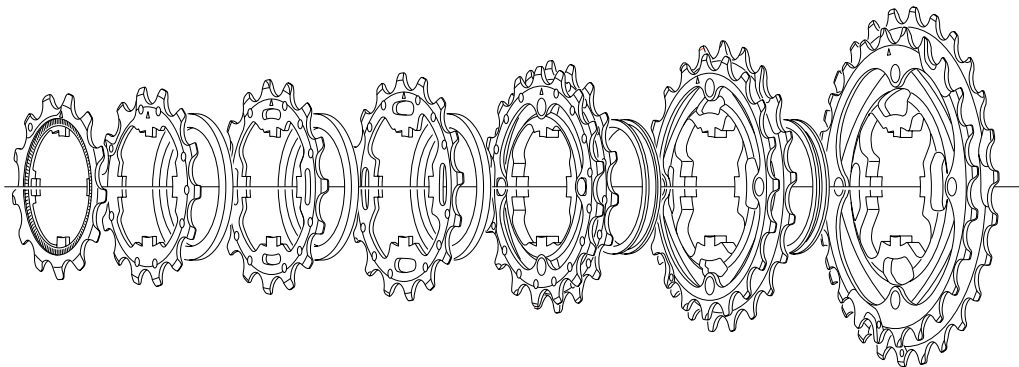

11 - 23	11A-1° 9S-011	12A-2° 10S-022T		13A 10S-131T	F	14A 10S-141T	F	15A 10S-151T	F	16A 10S-161T	G	17A-19A* 10S-79AT	H	21A-23A* 10S-13AT
12 - 25	12A-1° 10S-012T	13A 10S-131T	F	14A 10S-141T	F	15A 10S-151T	F	16A-17A* 10S-67AT	I	19A-21A* 10S-91AT	L	23A-25A* 10S-35AT		
13 - 26	13A-1° 10S-013T	14A 10S-141T	F	15A 10S-151T	F	16A 10S-161T	F	17A-18C* 10S-78CT	I	19C-21C* 10S-91CT	L	23C-26C* 10S-36CT		

\* pre-assembled

**CHORUS™**  
**UD 10s**  
**CSK00-CH10..**

DISTANZIALI / SPACERS
F = CS-601
G = CS-602
H = CS-603
I = CS-604
L = CS-605

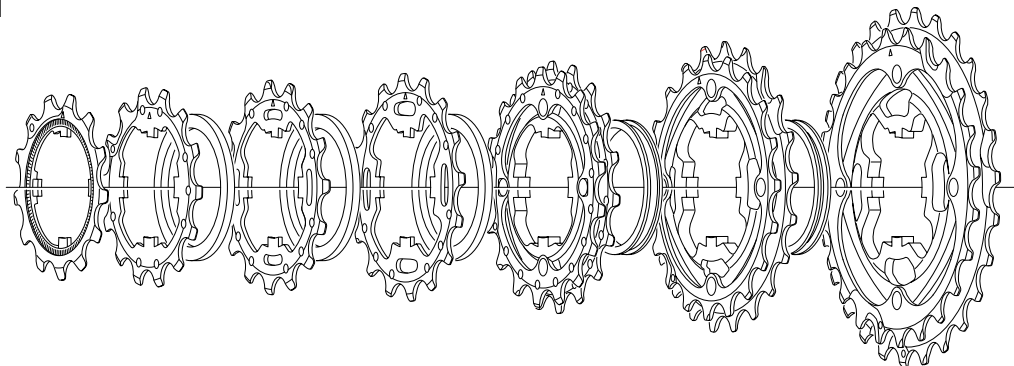

11 - 23	11A-1° 9S-011	12A-2° 10S-022		13A 10S-131	F	14A 10S-141	F	15A 10S-151	F	16A 10S-161	G	17A-19A* 10S-79A	H	21A-23A* 10S-13A
12 - 25	12A-1° 10S-012	13A 10S-131	F	14A 10S-141	F	15A 10S-151	F	16A-17A* 10S-67A	I	19A-21A* 10S-91A	L	23A-25A* 10S-35A		
13 - 26	13A-1° 10S-013	14A 10S-141	F	15A 10S-151	F	16A 10S-161	F	17A-18C* 10S-78C	I	19C-21C* 10S-91C	L	23C-26C* 10S-36C		
13 - 29	13A-1° 10S-013	14A 10S-141	F	15A 10S-151	F	16A 10S-161	F	17A-19A* 10S-79A	I	21A-23A* 10S-13A	L	26A-29A* 10S-69A		

\* pre-assembled

**CENTAUR™**  
**UD 10s**  
**CS4-CEX..**

**DISTANZIALI / SPACERS**

**F** = CS-601

**G** = CS-602

**M** = CS-606

**N** = CS-607

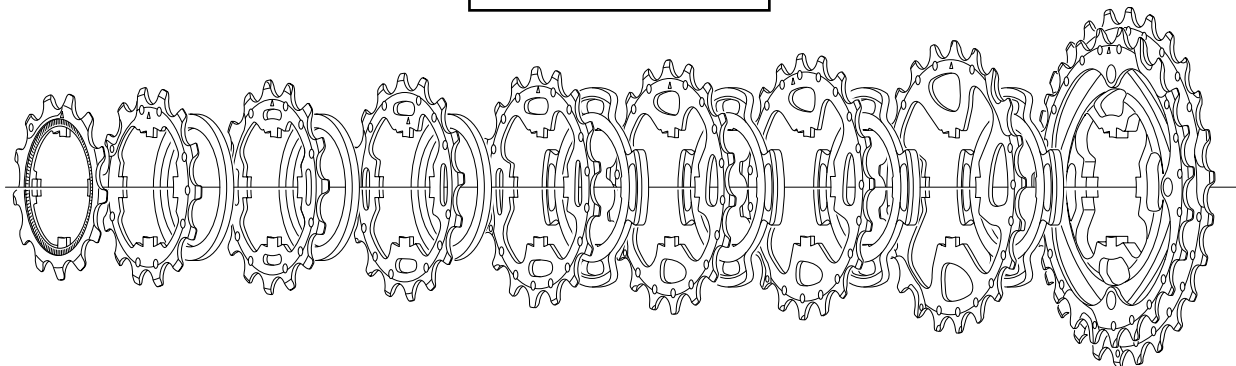

11 - 23	11A-1° 9S-011	12A-2° 10S-022		13A 10S-131	F	14A 10S-141	F	15A 10S-151	F	16A 10S-161	G	17A 10S-171	N	19A 10S-191	M	21A-23A* 10S-13A
12 - 25	12A-1° 10S-032	13A 10S-131	F	14A 10S-141	F	15A 10S-151	F	16A 10S-161	F	17A 10S-171	N	19A 10S-191	N	21A 10S-211	M	23A-25A* 10S-35A
13 - 26	13A-1° 10S-023	14A 10S-141	F	15A 10S-151	F	16A 10S-161	F	17A 10S-171	N	18C 10S-183	N	19C 10S-193	N	21C 10S-213	M	23C-26C* 10S-36C
13 - 29	13A-1° 10S-023	14A 10S-141	F	15A 10S-151	F	16A 10S-161	F	17A 10S-171	N	19A 10S-191	N	21A 10S-211	N	23A 10S-231	M	26A-29A* 10S-69A

\* pre-assembled

**VELOCE™ UD 10s**  
**CS4-VLX..**

**DISTANZIALI / SPACERS**

F = CS-601

N = CS-607

P = CS-608

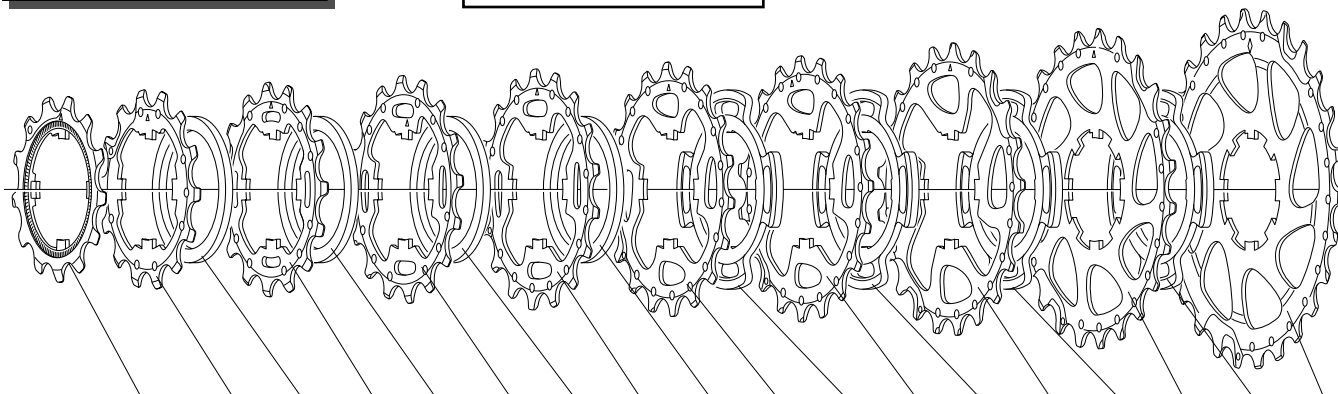

<b>12 - 23</b>	<b>12A-1°</b> 10S-032	<b>13A</b> 10S-131	<b>F</b>	<b>14A</b> 10S-141	<b>F</b>	<b>15A</b> 10S-151	<b>F</b>	<b>16A</b> 10S-161	<b>F</b>	<b>17A</b> 10S-171	<b>N</b>	<b>18C</b> 10S-193	<b>N</b>	<b>19C</b> 10S-193	<b>N</b>	<b>21C</b> 10S-213	<b>P</b>	<b>23C</b> 10S-233
<b>12 - 25</b>	<b>12A-1°</b> 10S-032	<b>13A</b> 10S-131	<b>F</b>	<b>14A</b> 10S-141	<b>F</b>	<b>15A</b> 10S-151	<b>F</b>	<b>16A</b> 10S-161	<b>F</b>	<b>17A</b> 10S-171	<b>N</b>	<b>19A</b> 10S-191	<b>N</b>	<b>21A</b> 10S-211	<b>N</b>	<b>23A</b> 10S-231	<b>P</b>	<b>25A</b> 10S-251
<b>13 - 26</b>	<b>13A-1°</b> 10S-023	<b>14A</b> 10S-141	<b>F</b>	<b>15A</b> 10S-151	<b>F</b>	<b>16A</b> 10S-161	<b>F</b>	<b>17A</b> 10S-171	<b>F</b>	<b>18C</b> 10S-183	<b>N</b>	<b>19C</b> 10S-193	<b>N</b>	<b>21C</b> 10S-213	<b>N</b>	<b>23C</b> 10S-233	<b>P</b>	<b>26C</b> 10S-263
<b>13 - 29</b>	<b>13A-1°</b> 10S-023	<b>14A</b> 10S-141	<b>F</b>	<b>15A</b> 10S-151	<b>F</b>	<b>16A</b> 10S-161	<b>F</b>	<b>17A</b> 10S-171	<b>F</b>	<b>19A</b> 10S-191	<b>N</b>	<b>21A</b> 10S-211	<b>N</b>	<b>23A</b> 10S-231	<b>N</b>	<b>26A</b> 10S-261	<b>P</b>	<b>29A</b> 10S-291
<b>14 - 23</b>	<b>14A-1°</b> 10S-014	<b>15A</b> 10S-151	<b>F</b>	<b>16A</b> 10S-161	<b>F</b>	<b>17A</b> 10S-171	<b>F</b>	<b>18C</b> 10S-183	<b>F</b>	<b>19C</b> 10S-193	<b>N</b>	<b>20D</b> 10S-204	<b>N</b>	<b>21D</b> 10S-214	<b>N</b>	<b>22D</b> 10S-224	<b>P</b>	<b>23D</b> 10S-234



**VELOCE™ UD 9s**  
CS01-EC09..

**MIRAGE UD 9s compatible**

CS-102

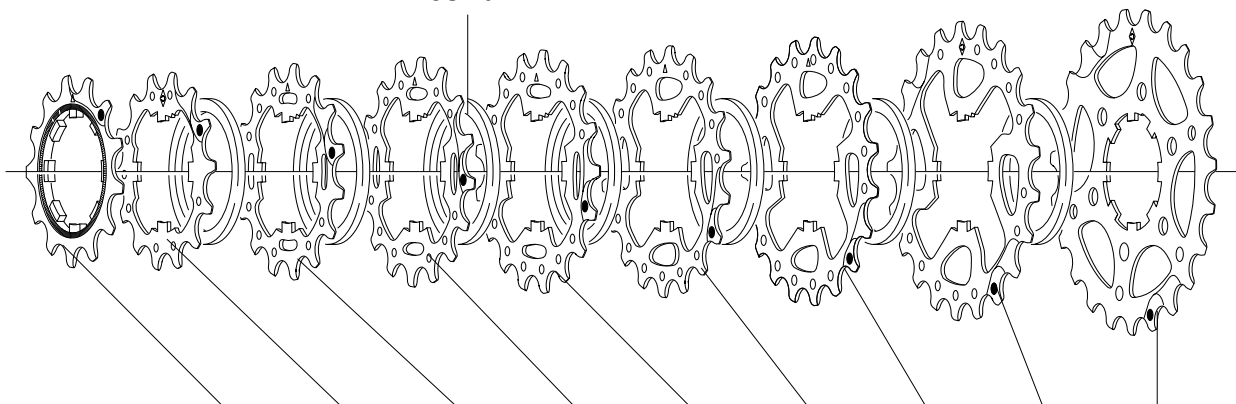

12 - 23	<b>12A-1°</b> 9S-113	<b>13A</b> 9S-131	<b>14A</b> 9S-141	<b>15A</b> 9S-151	<b>16A</b> 9S-161	<b>17A</b> 9S-171	<b>19A</b> 9S-191	<b>21A</b> 9S-211	<b>23A</b> 9S-231
13 - 23	<b>13A-1°</b> 9S-114	<b>14A</b> 9S-141	<b>15A</b> 9S-151	<b>16A</b> 9S-161	<b>17A</b> 9S-171	<b>18C</b> 9S-183	<b>19C</b> 9S-193	<b>21C</b> 9S-213	<b>23C</b> 9S-233
13 - 26	<b>13A-1°</b> 9S-114	<b>14A</b> 9S-141	<b>15A</b> 9S-151	<b>16A</b> 9S-161	<b>17A</b> 9S-171	<b>19A</b> 9S-191	<b>21A</b> 9S-211	<b>23A</b> 9S-231	<b>26A</b> 9S-261
13 - 28	<b>13B-1°</b> 9S-015	<b>14B</b> 9S-142	<b>15B</b> 9S-152	<b>17B</b> 9S-172	<b>19A</b> 9S-191	<b>21A</b> 9S-211	<b>23A</b> 9S-231	<b>25A</b> 9S-251	<b>28A</b> 9S-281
14 - 28	<b>14A-1°</b> 9S-016	<b>15A</b> 9S-151	<b>16A</b> 9S-161	<b>17A</b> 9S-171	<b>19A</b> 9S-191	<b>21A</b> 9S-211	<b>23A</b> 9S-231	<b>25A</b> 9S-251	<b>28A</b> 9S-281

**RECORD™**  
**PRO-FIT PLUS™**  
 PD01-RE

**CHORUS™**  
**PRO-FIT PLUS™**  
 PD01-CH

**CENTAUR™**  
**PRO-FIT PLUS™**  
 PD02-CE

<b>RECORD™</b>	R	PD-RE303
	L	PD-RE304

<b>CHORUS™</b>	R	PD-CH303
	L	PD-CH304

<b>CENTAUR™</b>	R	PD-DA003
	L	PD-DA004

<b>RECORD™</b>	R	PD-RE301
	L	PD-RE302

<b>CHORUS™</b>	R	PD-CH301
	L	PD-CH302

<b>CENTAUR™</b>	R	PD-CE001
	L	PD-CE002

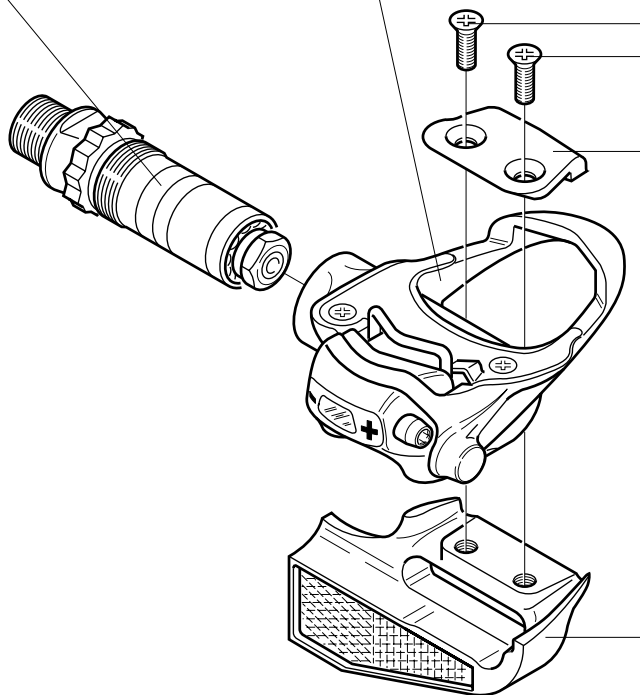

PD-RE108  
 (2 pcs.)

**PRO-FIT™ /  
PRO-FIT PLUS™  
SPARE PARTS**

R + L: PD-RE105

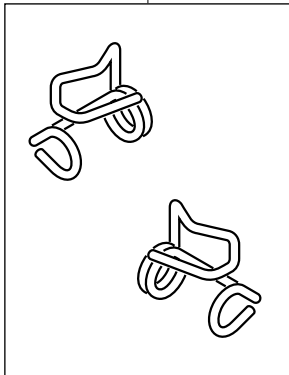

PD-RE107

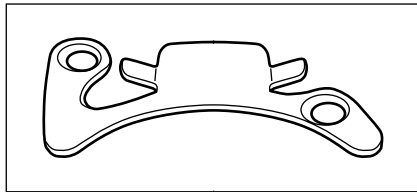
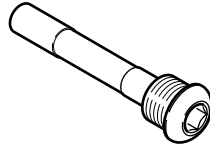

**PRO-FIT™  
PD-RE111**

PD-RE116 (blister)

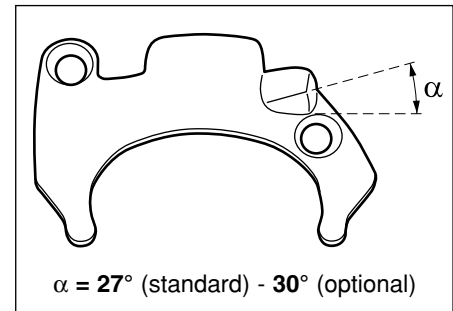
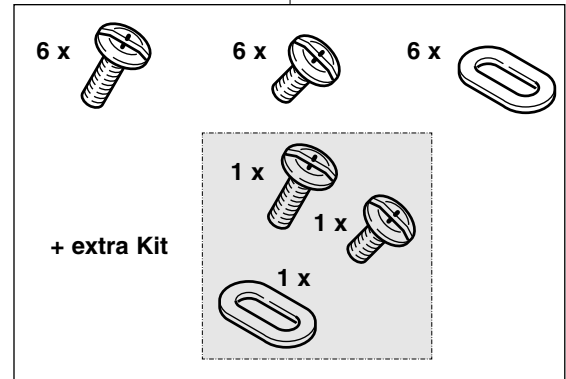

**PRO-FIT PLUS™**  
PD-RE110: standard -  $27^\circ$   
PD-RE109: HRE - optional -  $30^\circ$

**PRO-FIT™ /  
PRO-FIT PLUS™  
SPARE PARTS**

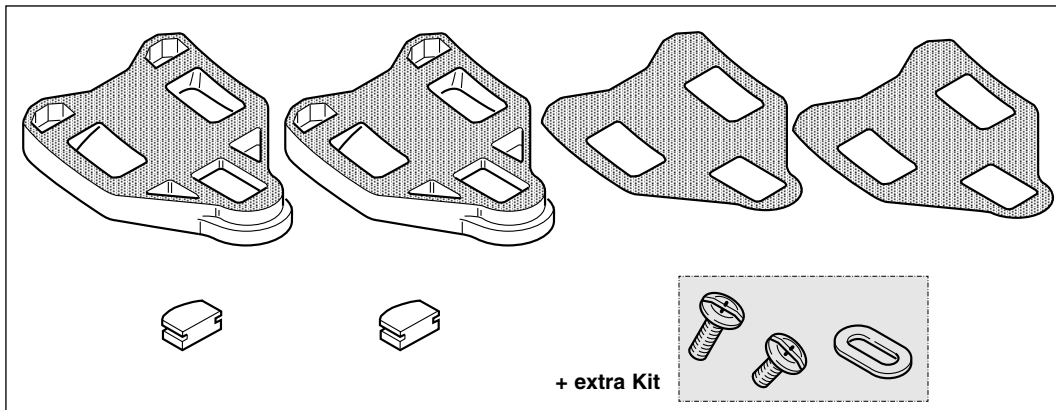

**FLOATING CLEATS  
PD-RE020  
(blister)**

**FIXED CLEATS  
PD-RE021  
(blister)**

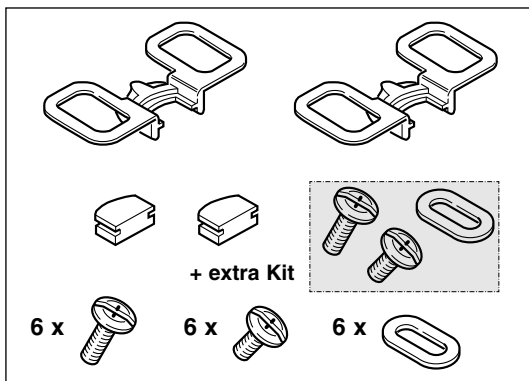

**PD-RE200 (blister)**

## CABLES & CASINGS complete sets

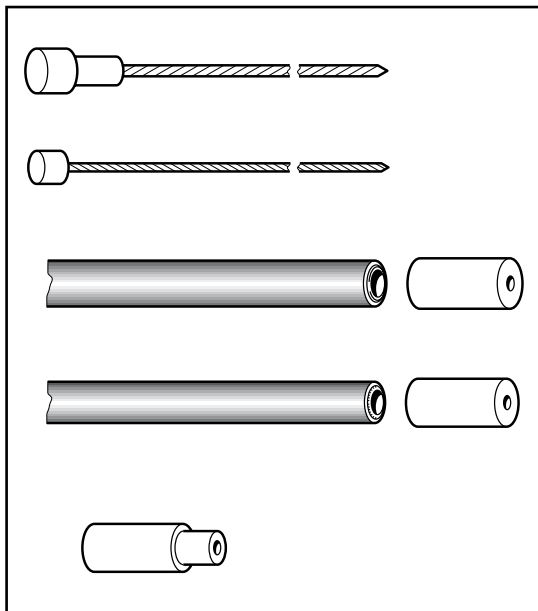

**ERGOPOWER**

CG-ER500 \*

CG-ER201BP (240 pcs. / pz.)

**TRADITIONAL**

**Brakes**



CG-BR201



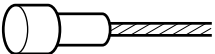

**Derailleurs**

CG-DD201

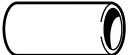
\* blister-packed (incl. brake housing ferrules) / in conf. blister (incl. capi guaina)

## CABLES & CASINGS SPARE PARTS

		FRONT	REAR
<b>BRAKES</b>		Ø 1,6 mm L. 800 mm <b>CG-CB003</b>	Ø 1,6 mm L. 1600 mm <b>10-CG-CB013</b> (10 pcs.) - <b>50-CG-CB013</b> (50 pcs.)
		Ø 5 mm L. 580 mm <b>CG-CS014</b>	Ø 5 mm L. 1250 mm <b>CG-CS002</b>
		Ø 6 mm <b>CG-CS011</b> (not sealed / senza guarnizione)	

<b>DERAILLEURS</b>	 Ø 1,2 mm	ERGOPOWER	L. 1600	<b>CG-CB014</b>
		ERGOPOWER	L. 2000	<b>10-CG-CB009</b> (10 pcs.) - <b>50-CG-CB009</b> (50 pcs.)
		SHIFTING LEVERS	L. 830	<b>CG-CB011</b>
		SHIFTING LEVERS	L. 1600	<b>CG-CB014</b>
	 Ø 4,5 mm	ERGOPOWER	L. 680	<b>CG-CS015</b>
		ERGOPOWER	L. 330	<b>CG-CS008</b>
		Ø 5,7 mm <b>CG-CS012</b> (sealed / con guarnizione)		
		Ø 5,7/4 mm <b>CG-CS013</b> (sealed / con guarnizione)		



ErgoBrain™

ErgoBrain10™

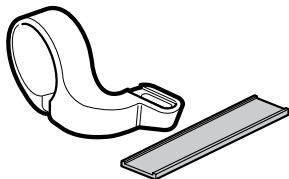

31,7 mm arm / fascetta 31,7 mm

**CI-EB001**

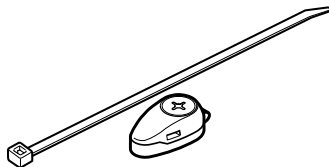

CDC magnet / magnete cadenza

**CI-EB003**

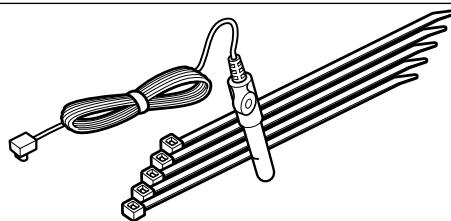

CDC sensor / sensore cadenza

**CI-EB006**

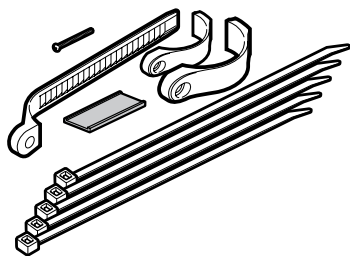

Sensor attachment / fascetta sensori

**CI-EB002**



CDC PRO-FIT pedal magnet /  
magnete cadenza pedale PRO-FIT

**CI-EB004**

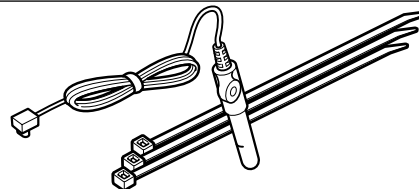

SPD sensor / sensore velocità

**CI-EB007**



push buttons / copripulsanti

**CI-EB009**



SPD magnet / magnete velocità

**CI-EB008**

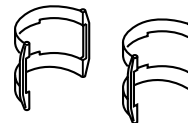

spacers / distanziali

**CI-EB010**



## ERGOPOWER BLOCKS

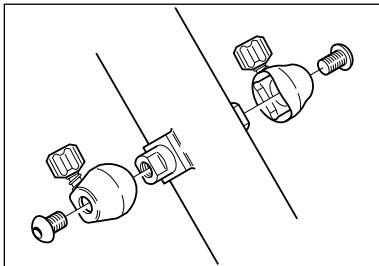

FOR ROUND DOWN TUBE

Aluminum: **EC-RE001**

Resin: **EC-AT001**

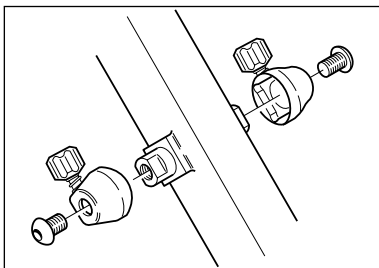

FOR FLAT DOWN TUBE

Resin: **EC-AT002**

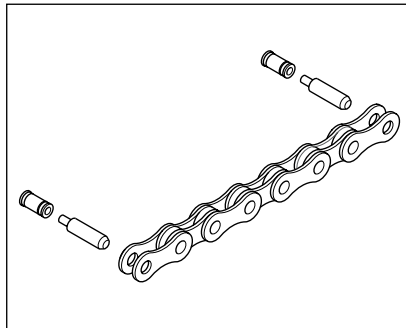

**CN-RE200**

**HD-Link™**

for C10™ UD™ and C10™ HD-L™  
chains (blister-packed)



**LB-1CN**

**SUPERLATIVE™**

chain lubricant

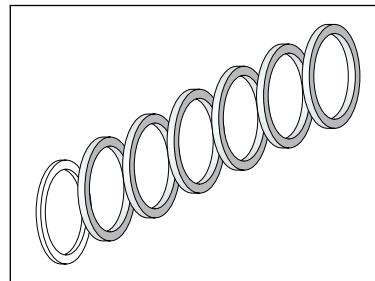

**KIT-03**

Transforms a Veloce™ 9s sprocket set into a 8s cassette.

**Only for 9s/10s hub/wheels.**

<b>RD-RE700</b>	rotelline cambio 10s (8,4 mm)	10s (8,4 mm) rear derailleur pulleys	jeu de galets dérail. arr. 10s (8,4 mm)
<b>RD-RE600</b>	rotelline cambio 9s (8,8 mm)	9s (8,8 mm) rear derailleur pulleys	jeu de galets dérail. arr. 9s (8,8 mm)
<b>RD-RE500</b>	rotelline cambio 8s (9,8 mm)	8s (9,8 mm) rear derailleur pulleys	jeu de galets dérail. arr. 8s (9,8 mm)
<b>EC-RE600</b>	coprisupporti EP dx + sx "new style"	right + left EP rubber hoods (new style)	repose-main EP droit + gauche "new style"
<b>EC-RE500</b>	coprisupporti EP dx + sx "old style"	right + left EP rubber hoods (old style)	repose-main EP droit + gauche "old style"
<b>BR-RE701</b>	pattini freno per ruote HYPERON™ e BORA™ 2003 tubolare	brake pads for HYPERON™ and BORA™ 2003 tubular wheels	patins de frein roues HYPERON™ et BORA™ 2003 boyaux
<b>BR-RE702</b>	pattini freno per ruote HYPERON™ copertoncino	brake pads for HYPERON™ clincher wheels	patins de frein roues HYPERON™ pneus étroits
<b>BR-RE700</b>	pattini freno	brake pads	patins de frein
<b>BR-RE600</b>	pattini freno	brake pads	patins de frein
<b>BR-MI600</b>	pattini freno compl.	compl. brake pads	patins de frein compl.
<b>BL-RE500</b>	coprisupporti tradizionali dx + sx (gamma 2000 e prec.)	r + l traditional rubber hoods (2000 range and prev.)	repose-main trad. droit + gauche (gamme 2000 et préc.)
<b>PD-RE020</b>	tacchette pedali (con gioco)	self-aligning pedal cleats	plaques avec jeu pour pédales
<b>PD-RE021</b>	tacchette pedali (senza gioco)	fixed pedal cleats	plaques sans jeu pour pédales
<b>PD-RE200</b>	denti d'aggancio pedali + viti	pedal engaging hooks + screws	dispositifs d'accrochage pédales + vis
<b>PD-RE116</b>	viti fissaggio tacchette pedali	pedal cleats fixing screws	vis fixation plaques pédales
<b>CG-ER500</b>	cavi e guaine EP (con capi-guaina)	EP cables and casings (with brake housing ferrules)	câbles et gaines EP (avec butée de gaines)
<b>CN-RE200</b>	HD-LINK™ per catene C10™ UD™ e HD-L™	HD-LINK™ for C10™ UD™ and HD-L™ chains	HD-LINK™ for C10™ UD™ and HD-L™ chains

**HYPERON Ultra /  
HYPERON  
clincher  
9s / 10s**

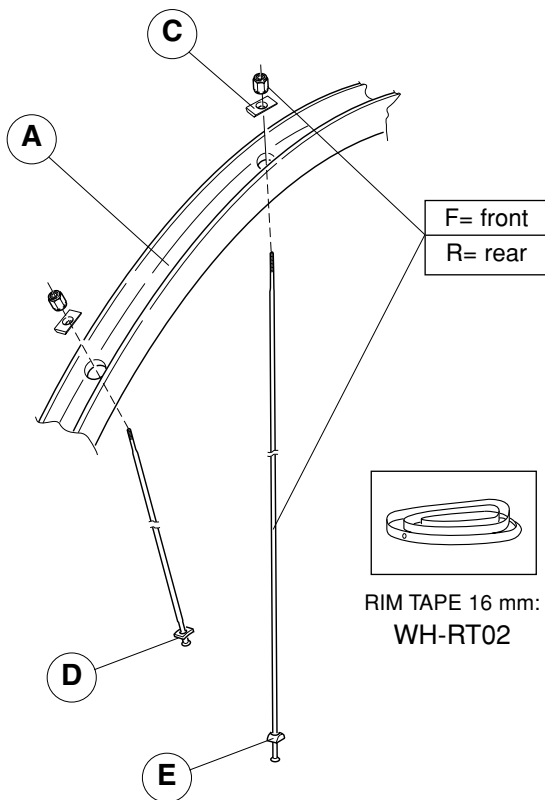

COMPLETE WHEELS	A	Compl. KIT	MINI-KIT
<b>FRONT</b>			
WH4-HYCFU clincher 28"	WH-003HYU	KIT-03HYU (24F+24C)	<b>HYPERON ULTRA KIT-200HYU</b> (2F+2R right +2R left+6C+2E)
WH4-HYCF clincher 28"	WH-003HY	KIT-03HY (24F+24C)	
<b>REAR</b>			
WH4-HYCRU clincher 28"	WH-004HYU	KIT-04HYU (13R right+13R left+26C+13E)	<b>HYPERON KIT-200HY</b> (2F+2R right +2R left+6C+2E)
WH4-HYCR WH4-HYCRX clincher 28"	WH-004HY	KIT-04HY (13R right+13R left+26C+13E)	

COMPLETE WHEELS	F	R right	R left
WH4-HYCFU clincher 28"	L. 292 mm WH-005HYC (10 pcs.)		
WH4-HYCF clincher 28"	L. 292 mm WH-005HYC (10 pcs.)		
WH4-HYCRU clincher 28"		L. 292 mm WH-006HYC (10 pcs.)	L. 291 mm WH-007HYC (10 pcs.)
WH4-HYCR WH4-HYCRX clincher 28"		L. 292 mm WH-006HYC (10 pcs.)	L. 291 mm WH-008HYC (10 pcs.)

**HYPERON**  
*tubular*  
**9s / 10s**

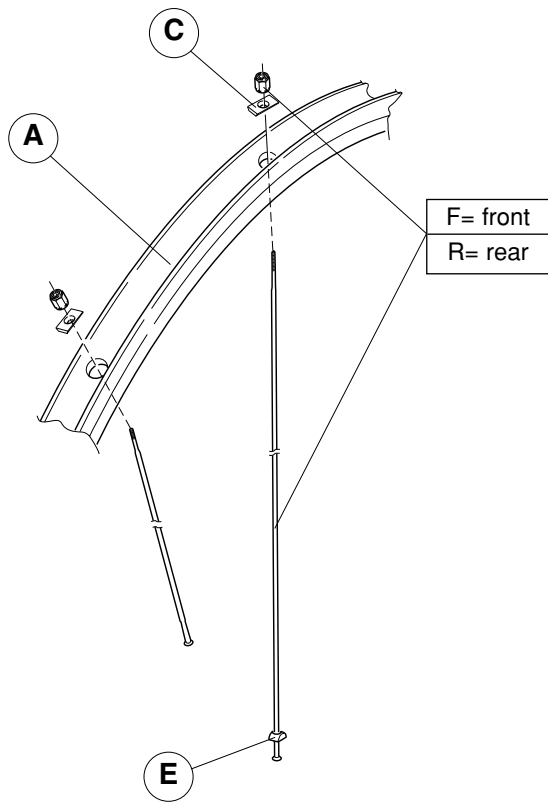

COMPLETE WHEELS	A	Compl. KIT	MINI-KIT
<b>FRONT</b>			<b>KIT-100HY</b> (2F+2R right +2R left+6C+2E)
<b>WH02-HYTF</b> tubular 28"	<b>WH-001HY</b>	<b>KIT-01HY</b> (24F+24C)	
<b>REAR</b>			
<b>WH02-HYTR</b> <b>WH02-HYTRX</b> tubular 28"	<b>WH-002HY</b>	<b>KIT-02HY</b> (13R right+13R left+26C+13E)	

COMPLETE WHEELS	F	R right	R left
<b>WH02-HYTF</b> tubular 28"	L. 294,5 mm WH-005HYT (10 pcs.)		
<b>WH02-HYTR</b> <b>WH02-HYTRX</b> tubular 28"		L. 295 mm WH-006HYT (10 pcs.)	L. 294,5 mm WH-007HYT (10 pcs.)

## NEUTRON 9s / 10s

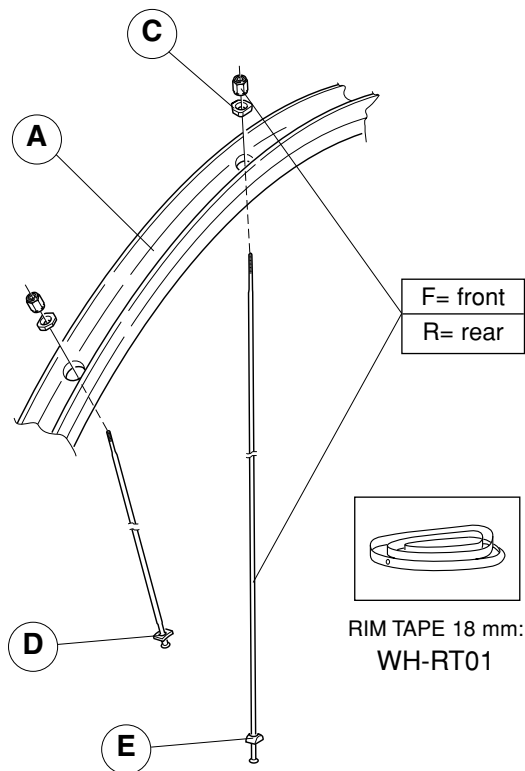

COMPLETE WHEELS	A	Compl. KIT	MINI-KIT
<b>FRONT</b>			
<b>WH02-NETF</b> tubular 28"	<b>WH-001NE</b>	<b>KIT-01NE</b> (24F+24C+24D)	<u>tubular</u> <b>KIT-100NE</b> (2F+2R right +2R left+6C+4D+2E)
<b>WH4-NECF</b> clinchers 28"	<b>WH-103NE</b>	<b>KIT-03NE</b> (24F+24C+24D)	
<b>REAR</b>			
<b>WH02-NETR</b> <b>WH02-NETRX</b> tubular 28"	<b>WH-002NE</b>	<b>KIT-02NE</b> (13R right+13R left+26C+13D+13E)	<u>clinchers</u> <b>KIT-200NE</b> (2F+2R right +2R left+6C+4D+2E)
<b>WH4-NECR</b> <b>WH4-NECRX</b> clinchers 28"	<b>WH-104NE</b>	<b>KIT-04NE</b> (13R right+13R left+26C+13D+13E)	
COMPLETE WHEELS	F	R right	R left
<b>WH02-NETF</b> tubular 28"	L. 296,5 mm WH-005NET (10 pcs.)		
<b>WH4-NECF</b> clinchers 28"	L. 294,25 mm WH-005NEC (10 pcs.)		
<b>WH02-NETR</b> <b>WH02-NETRX</b> tubular 28"		L. 299,5 mm WH-006NET (10 pcs.)	L. 296,5 mm WH-007NET (10 pcs.)
<b>WH4-NECR</b> <b>WH4-NECRX</b> clinchers 28"		L. 296,5 mm WH-006NEC (10 pcs.)	L. 294,75 mm WH-007NEC (10 pcs.)

# PROTON 9s / 10s

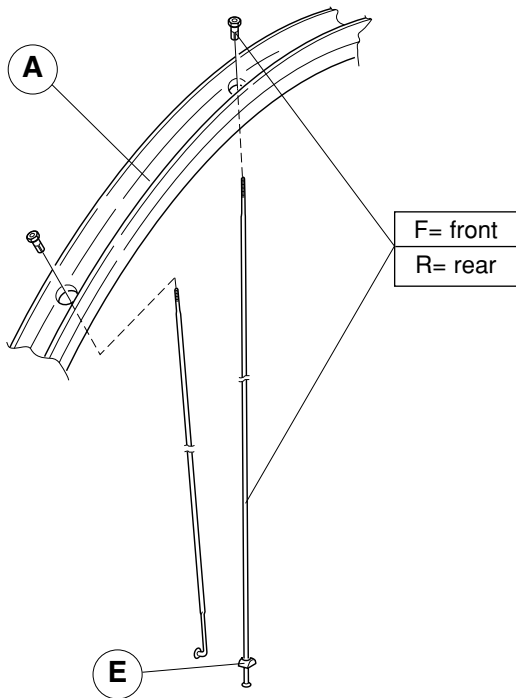

COMPLETE WHEELS	A	Compl. KIT	MINI-KIT
<b>FRONT</b>			
WH4-PRCF clincher 28"	WH-201PR	KIT-03PR (24F)	KIT-400PR (2F+2R right +2R left+2E)
<b>REAR</b>			
WH4-PRCR WH4-PRCRX clincher 28"	WH-202PR	KIT-04PR (13R right+13R left+13E)	

COMPLETE WHEELS	F	R right	R left
WH4-PRCF clincher 28"	L. 283 mm WH-005PRC (10 pcs.)		
WH4-PRCR WH4-PRCRX clincher 28"		L. 292 mm WH-006PRC (10 pcs.)	L. 283 mm WH-005PRC (10 pcs.)

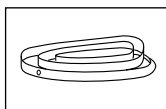

RIM TAPE 18 mm:  
WH-RT01

## EURUS 9s / 10s

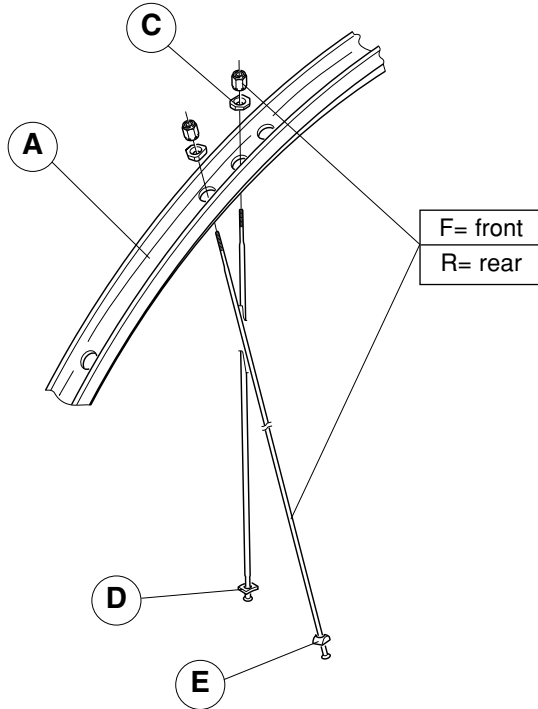

COMPLETE WHEELS	A	Compl. KIT	MINI-KIT
<b>FRONT</b>			
WH02-EUCF clincher 28"	WH-003EU	KIT-03EU (18F+18C+18D)	<b>KIT-200EU</b> (2F+2R right +2R left+6C+4D+2E)
<b>REAR</b>			
WH02-EUCR WH02-EUCRX clincher 28"	WH-004EU	KIT-04EU (15R right+8R left+23C+8D+15E)	

COMPLETE WHEELS	F	R right	R left
WH02-EUCF clincher 28"	L. 285 mm WH-005EUC (10 pcs.)		
WH02-EUCR WH02-EUCRX clincher 28"		L. 288 mm WH-006EUC (10 pcs.)	L. 285 mm WH-007EUC (10 pcs.)

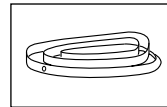

RIM TAPE 18 mm:  
WH-RT01

# ZONDA 9s / 10s

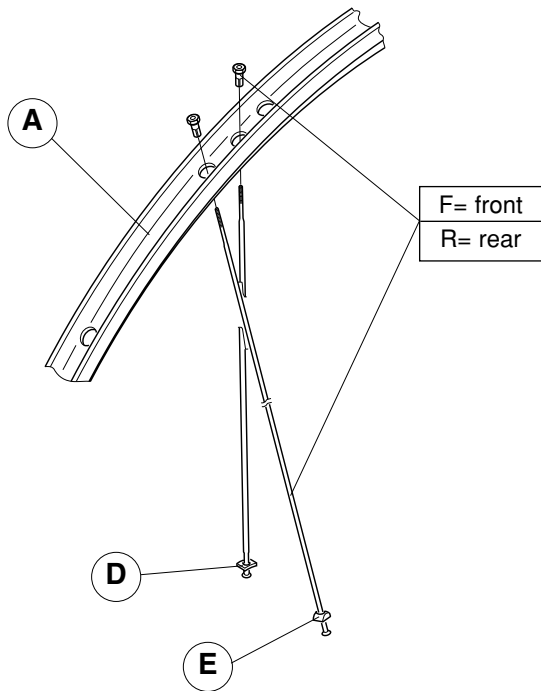

COMPLETE WHEELS	A	Compl. KIT	MINI-KIT
<b>FRONT</b>			
<b>WH4-ZOCF</b> clincher 28"	<b>WH-103ZO</b>	<b>KIT-13ZO</b> (18F+18D)	<b>KIT-300ZO</b> (2F+2R right +2R left+2E+4D)
<b>REAR</b>			
<b>WH4-ZOCR</b> <b>WH4-ZOCRX</b> clincher 28"	<b>WH-104ZO</b>	<b>KIT-14ZO</b> (15R right+8R left +8D+15E)	

COMPLETE WHEELS	F	R right	R left
<b>WH4-ZOCF</b> clincher 28"	L. 279 mm WH-005ZOC (10 pcs.)		
<b>WH4-ZOCR</b> <b>WH4-ZOCRX</b> clincher 28"		L. 282 mm WH-006ZOC (10 pcs.)	L. 279 mm WH-007ZOC (10 pcs.)

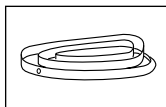

RIM TAPE 18 mm:  
WH-RT01



## SCIROCCO 9s / 10s

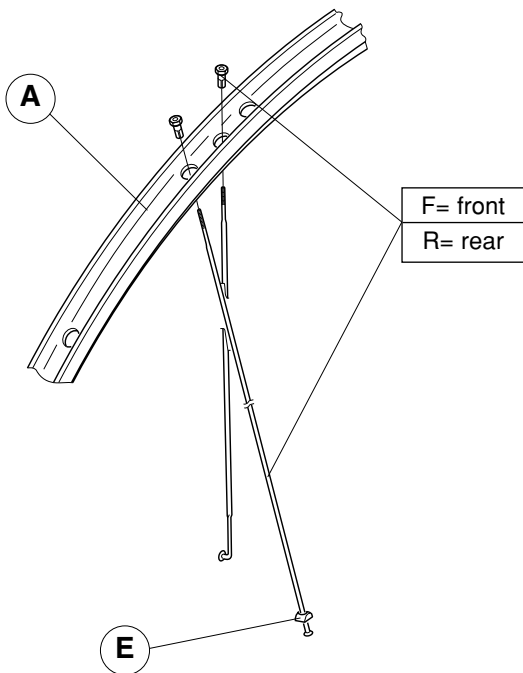

COMPLETE WHEELS	A	Compl. KIT	MINI-KIT
<b>FRONT</b>			<b>KIT-500SC</b> (2F+2R right +2R left+2E)
<b>WH4-SCCF</b> clincher 28"	<b>WH-003SC</b>	<b>KIT-23SC</b> (26F)	
<b>REAR</b>			
<b>WH4-SCCR</b> <b>WH4-SCCRX</b> clincher 28"	<b>WH-004SC</b>	<b>KIT-14SC</b> (17R right+9R left+17E)	

COMPLETE WHEELS	F	R right	R left
<b>WH4-SCCF</b> clincher 28"	L. 274 mm WH-005SCC (10 pcs.)		
<b>WH4-SCCR</b> <b>WH4-SCCRX</b> clincher 28"		L. 279 mm WH-006SCC (10 pcs.)	L. 272 mm WH-007SCC (10 pcs.)

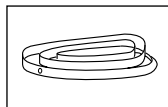

RIM TAPE 18 mm:  
WH-RT01

# VENTO 9s / 10s

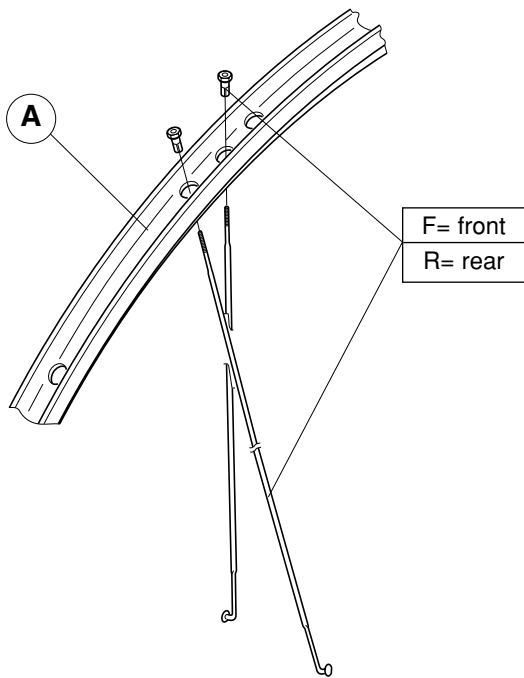

COMPLETE WHEELS	A	Compl. KIT	MINI-KIT
<b>FRONT</b>			
<b>WH4-VECF</b> clincher 28"	<b>WH-003VE</b>	<b>KIT-03VE</b> (26F)	<b>KIT-400VE</b> (2F+2R right +2R left)
<b>REAR</b>			
<b>WH4-VECR</b> <b>WH4-VECRX</b> clincher 28"	<b>WH-004VE</b>	<b>KIT-04VE</b> (19R right+10R left)	

COMPLETE WHEELS	F	R right	R left
<b>WH4-VECF</b> clincher 28"	L. 278 mm WH-005VEC (10 pcs.)		
<b>WH4-VECR</b> <b>WH4-VECRX</b> clincher 28"		L. 288 mm WH-006VEC (10 pcs.)	L. 278 mm WH-007VEC (10 pcs.)

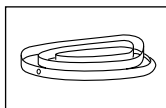

RIM TAPE 16 mm:  
WH-RT02

**BORA**  
**"full carbon"**  
**9s / 10s**

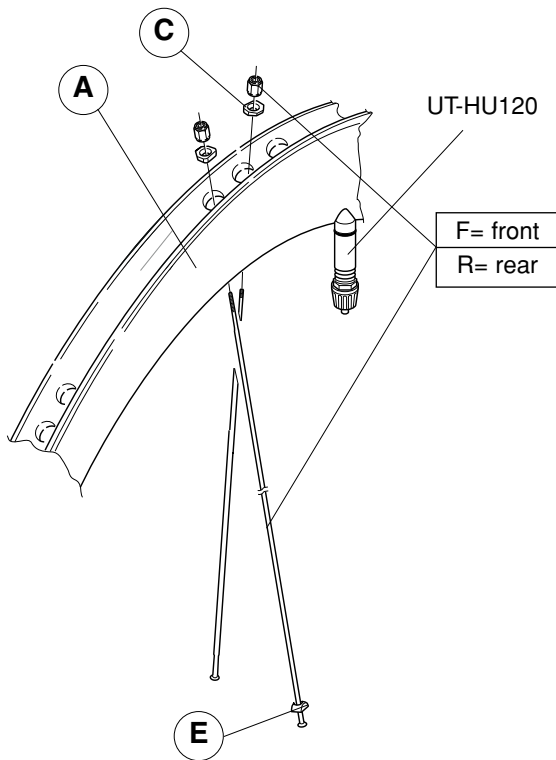

COMPLETE WHEELS	A	Compl. KIT	MINI-KIT
<b>FRONT</b>			
<b>WH03-BOTF</b> tubular 28"	<b>WH-301BO</b>	<b>KIT-21BO</b> (20F+20C)	<b>KIT-200BO</b> (2F+2R right +2R left+6C+2E)
<b>REAR</b>			
<b>WH03-BOTR</b> <b>WH03-BOTRX</b> tubular 28"	<b>WH-302BO</b>	<b>KIT-22BO</b> (15R right+8R left+23C+15E)	

COMPLETE WHEELS	F	R right	R left
<b>WH03-BOTF</b> tubular 28"	L. 264 mm WH-005BOT (10 pcs.)		
<b>WH03-BOTR</b> <b>WH03-BOTRX</b> tubular 28"		L. 268 mm WH-006BOT (10 pcs.)	L. 268 mm WH-007BOT (10 pcs.)

# PISTA

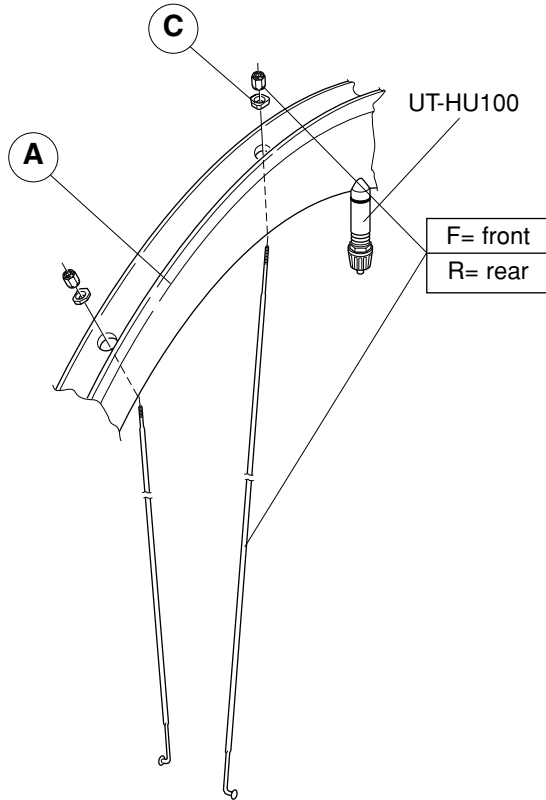

COMPLETE WHEELS	A	Compl. KIT	MINI-KIT
<b>FRONT</b>			<b>KIT-100PI</b> (3F+3R+6C)
<b>WH02-PTF</b> tubular 28"	<b>WH-001PI</b>	<b>KIT-01PI</b> (22F+22C)	
<b>REAR</b>			
<b>WH02-PTR</b> tubular 28"	<b>WH-002PI</b>	<b>KIT-02PI</b> (26R+26C)	

COMPLETE WHEELS	F	R
<b>WH02-PTF</b> tubular 28"	L. 278 mm WH-005PIT (10 pcs.)	
<b>WH02-PTR</b> tubular 28"		L. 287 mm WH-006PIT (10 pcs.)

**MOZZO ANTERIORE**  
***HYPERON tub. / HYPERON ULTRA clincher / BORA "full carbon" tub.***  
**FRONT HUB**

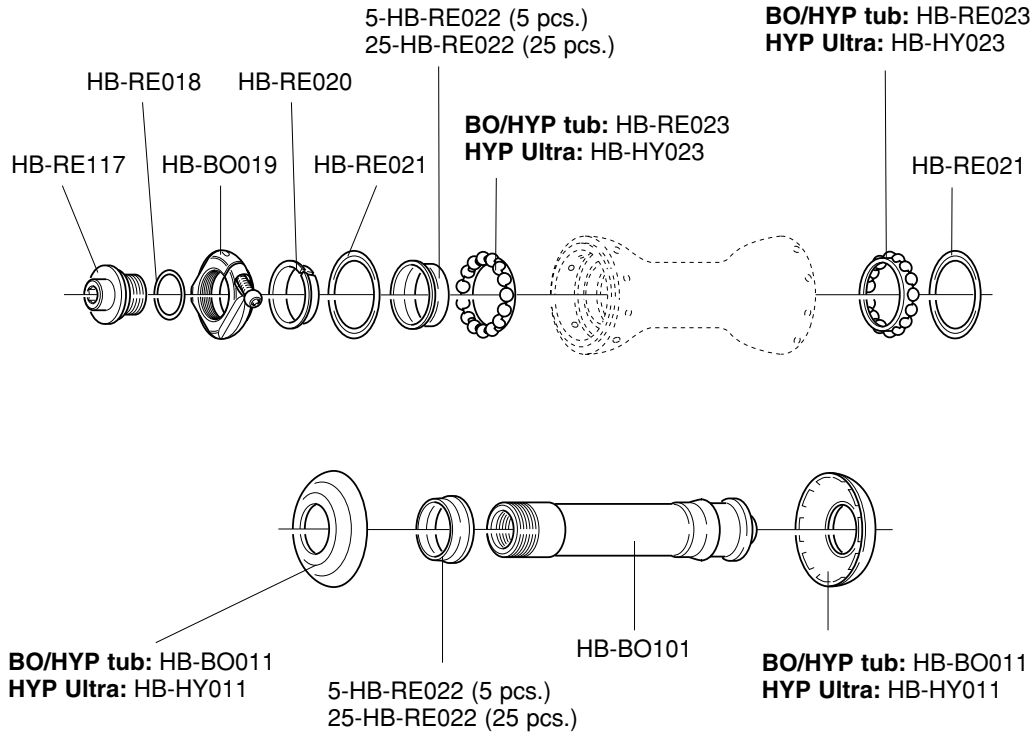

**MOZZO POSTERIORE 9s / 10s**  
***HYPERON tub. / HYPERON ULTRA clincher / BORA "full carbon" tub.***  
**9s / 10s REAR HUB**

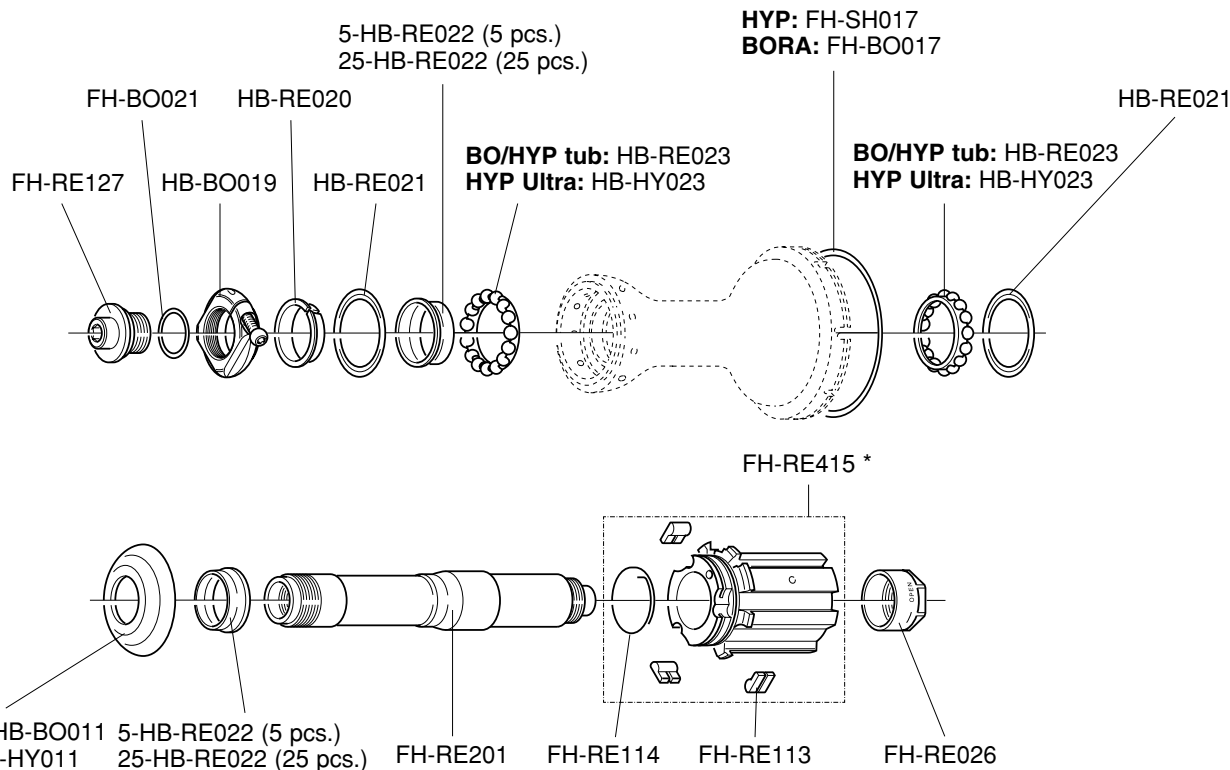

\* HG 8/9 type FW body / corpetto RL tipo HG 8/9: **WH-KX1** (RECORD type) **WH-KX2** (CHORUS type)

**MOZZO ANTERIORE**  
**NEUTRON - EURUS - HYPERON clincher - ZONDA**  
**FRONT HUB**

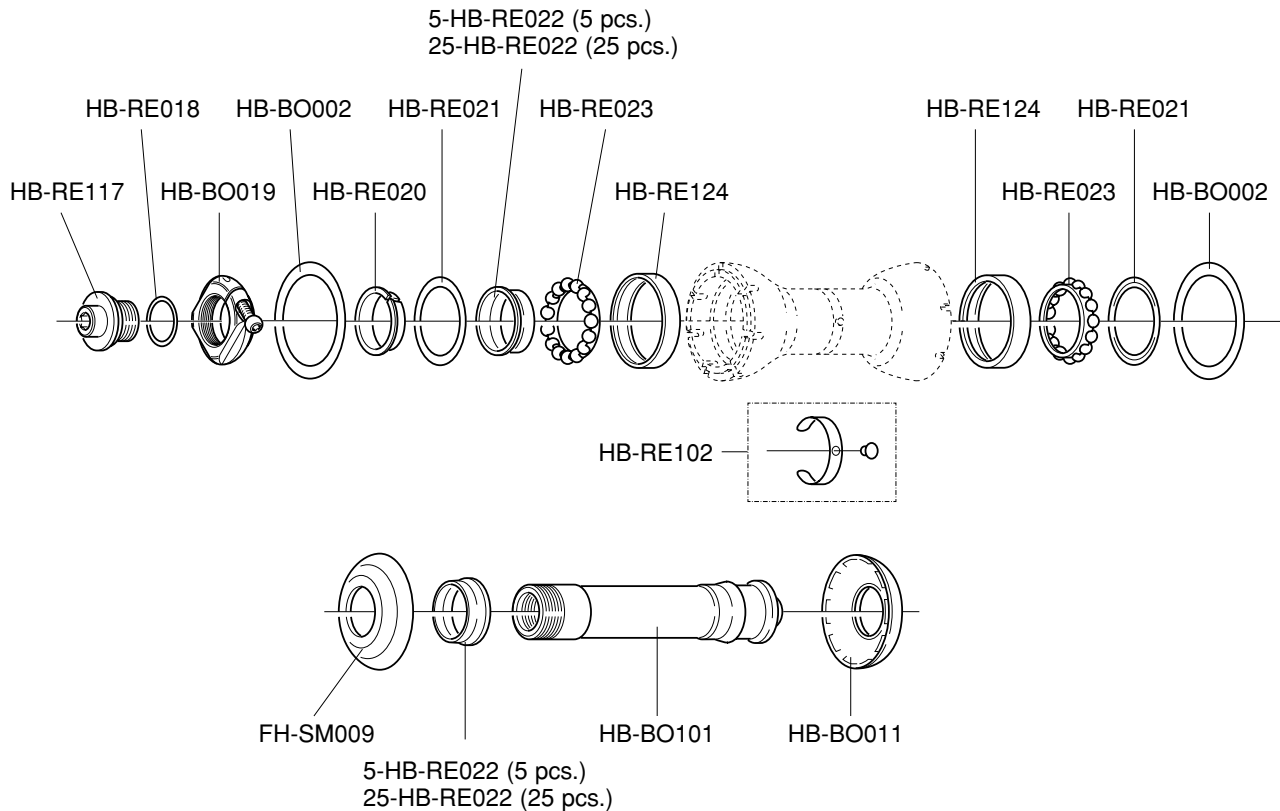

**MOZZO POSTERIORE 9s / 10s**  
**NEUTRON - EURUS - HYPERON clincher - ZONDA**  
**9s / 10s REAR HUB**

5-HB-RE022 (5 pcs.)  
 25-HB-RE022 (25 pcs.)

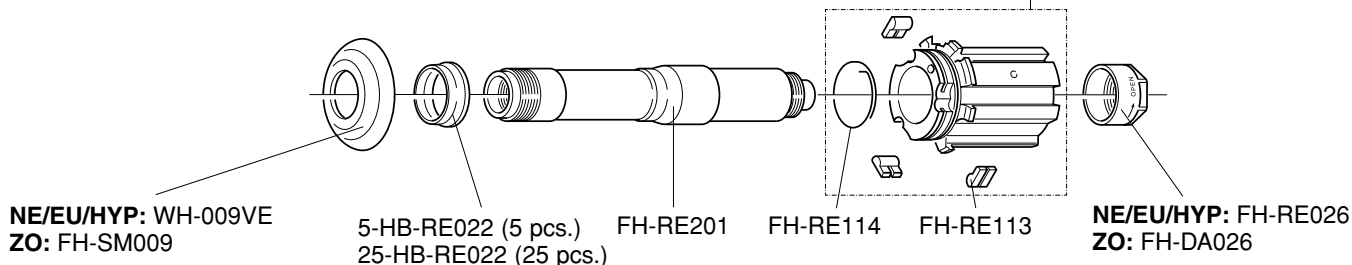
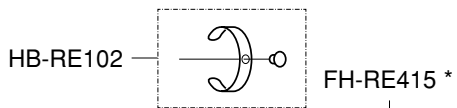
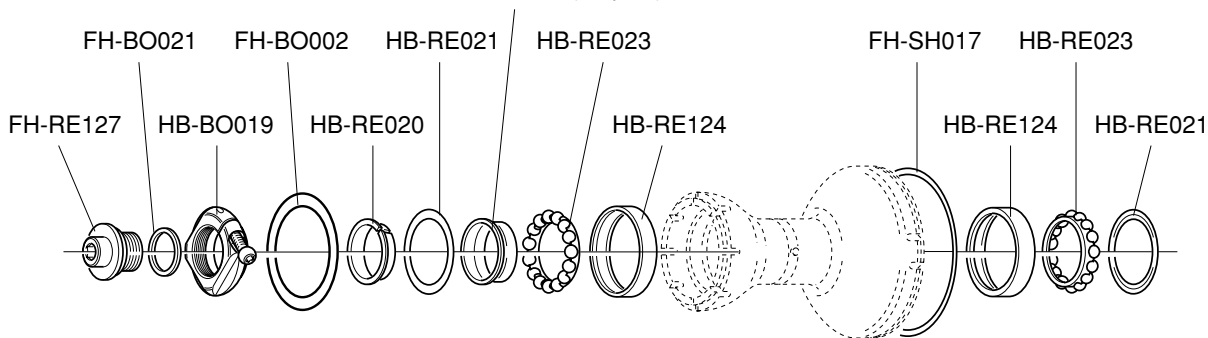

\* HG 8/9 type FW body / corpetto RL tipo HG 8/9: **WH-KX1** (RECORD type) **WH-KX2** (CHORUS type)



## MOZZO ANTERIORE *PROTON* FRONT HUB

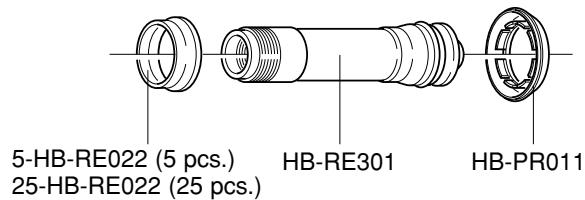
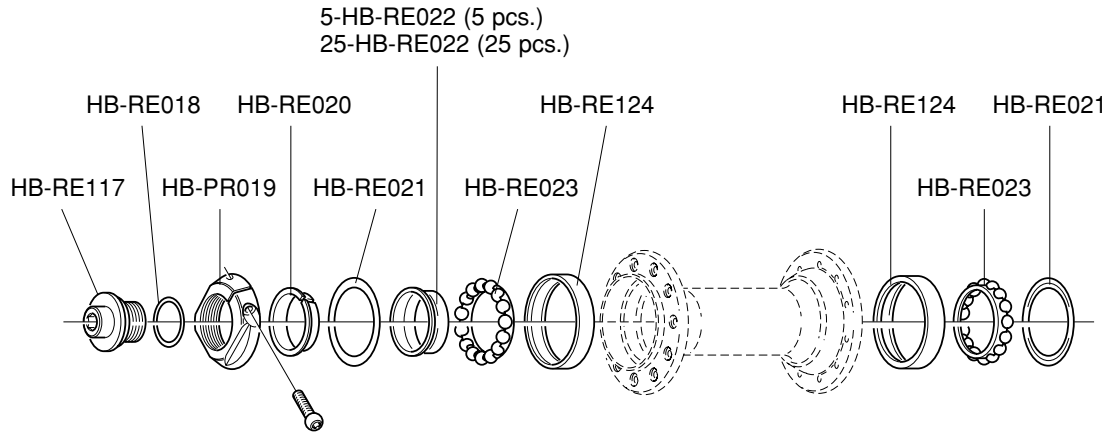

**MOZZO POSTERIORE 9s / 10s**  
**PROTON**  
**9s / 10s REAR HUB**

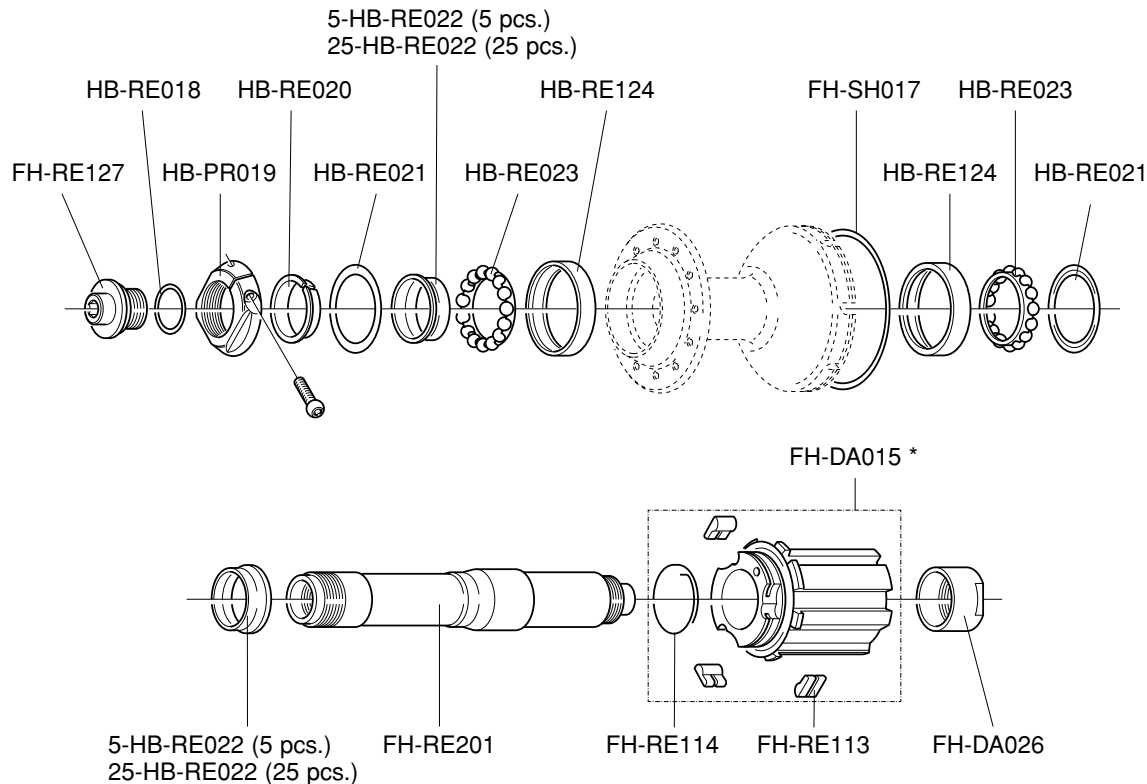

\* HG 8/9 type FW body / corpetto RL tipo HG 8/9: **WH-KX1** (RECORD type) **WH-KX2** (CHORUS type)

**MOZZO ANTERIORE  
e POSTERIORE  
*SCIROCCO*  
FRONT and REAR HUB**

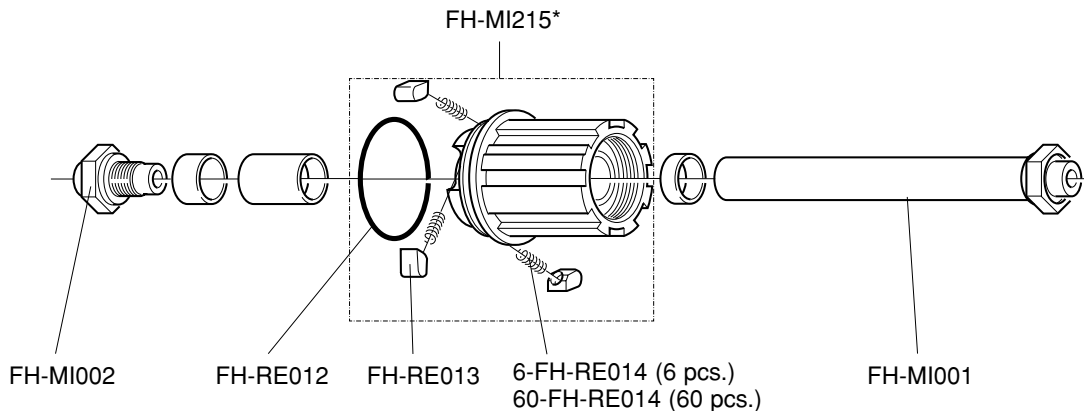
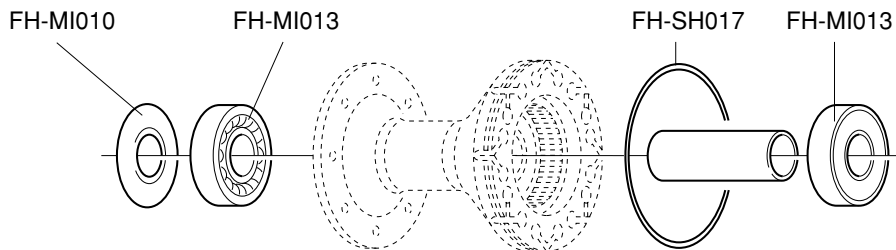
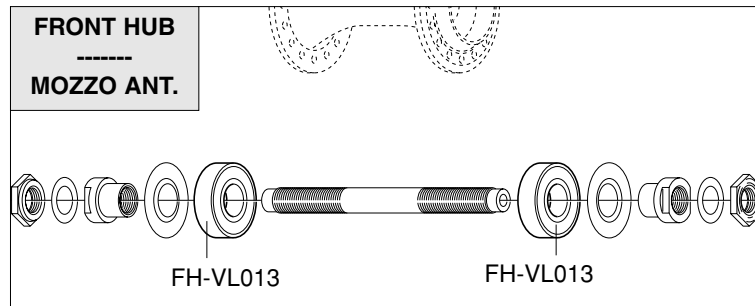

\* HG 8/9 type FW body / corpetto RL tipo HG 8/9: **WH-KX3**

**MOZZO ANTERIORE  
*PISTA*  
FRONT HUB**

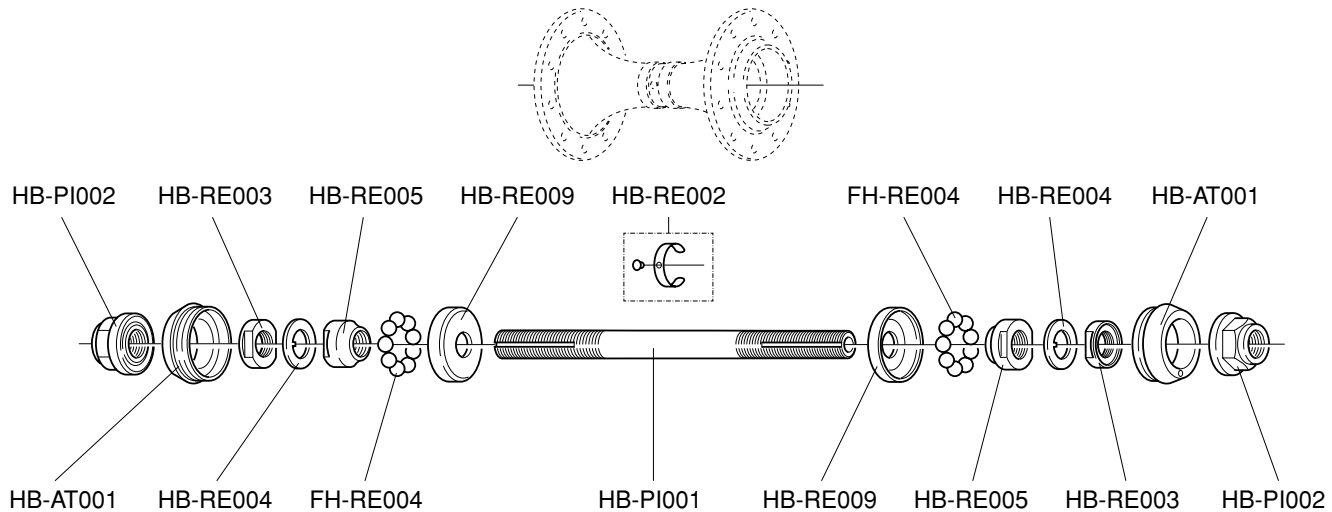

## MOZZO POSTERIORE *PISTA* REAR HUB

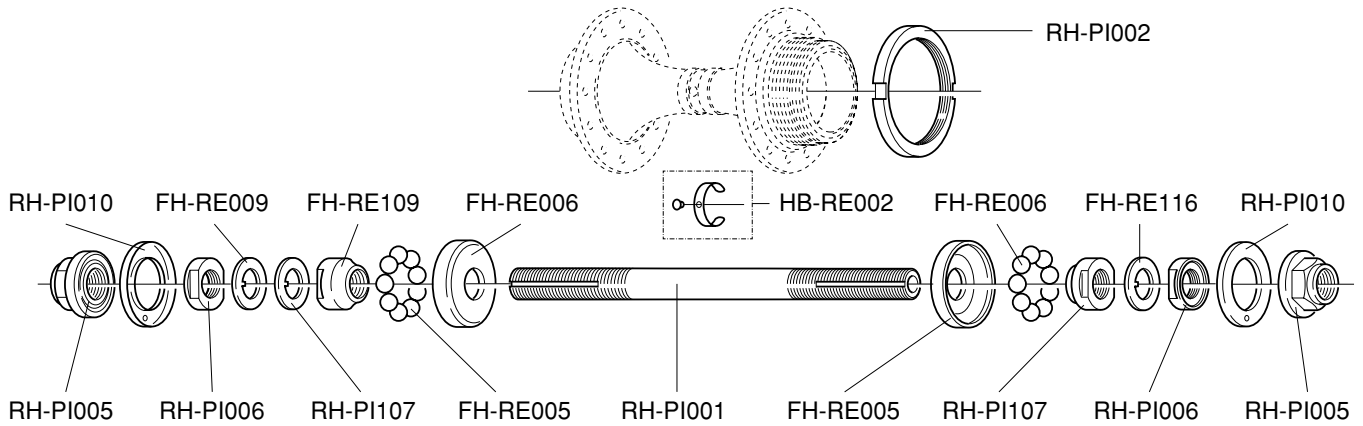

**MOZZO ANTERIORE  
e POSTERIORE  
VENTO  
FRONT and REAR HUB**

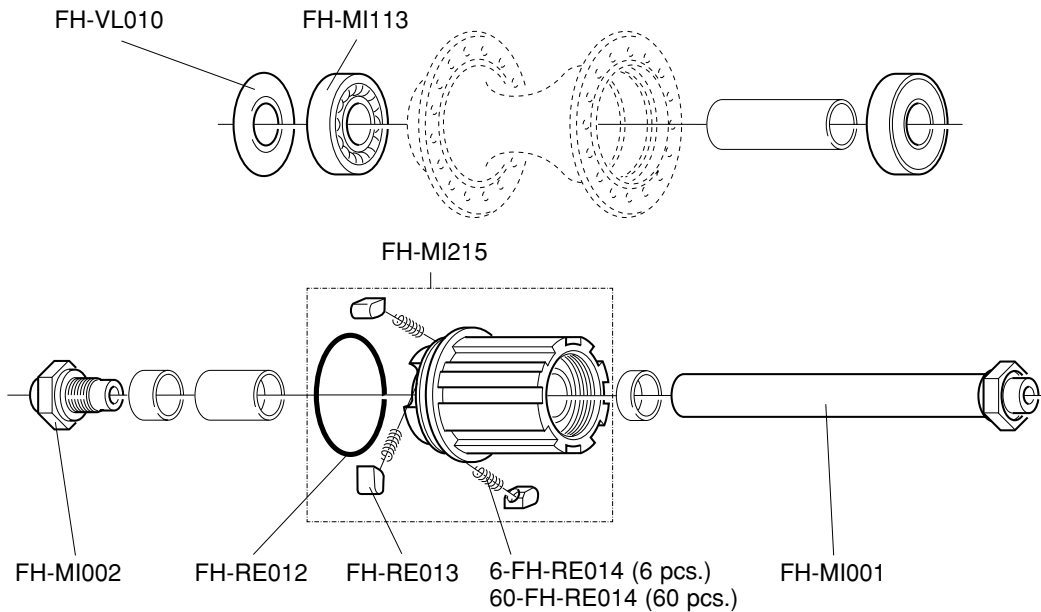
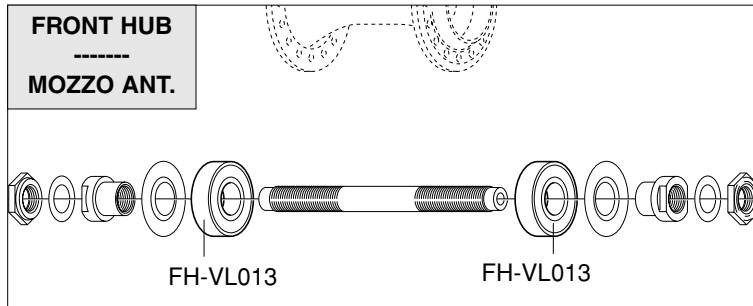

\* HG 8/9 type FW body / corpetto RL tipo HG 8/9: **WH-KX3**

## Utensili raccomandati reperibili in commercio

### Recommended tools, commercially available

---

- Cacciavite a croce PH 1 (Phillips)
  - Chiave a manico di cacciavite con esagono da 5mm per ruote:
    - Nucleon ed Electron
    - Shamal e Vento (solo da gamma '99 - per gamme precedenti vedi pag. 115)
  - Chiave a brugola da 2,5 mm per registrazione mozzi
  - Chiave a brugola da 3 mm per blocchetti fermaguaine
  - Chiave a brugola da 5 mm per freni, Ergopower, ecc.
  - Chiave dinamometrica con chiave a brugola da 8 mm per montaggio viti pedivelle
  - Chiave fissa da 17 mm per controdado mozzo posteriore
  - Chiave a bussola da 24 mm per utensile fissaggio calotte mov. centrale Daytona/Centaur, Veloce, Mirage (UT-BB100 - pag. 108)
  - Maschio M10 x 1 per ripasso occhiello attacco cambio su forcellini
  - Chiave TORX per viti fissaggio ingranaggi guarniture RECORD e CHORUS CARBON gamma 2004
- 
- Phillips type screwdriver
  - 5 mm nut driver for wheels:
    - Nucleon and Electron
    - Shamal and Vento (only from '99 range - for previous versions see page 115)
  - 2.5 mm allen key, for hub lock nut
  - 3 mm allen key, for downtube adjusters
  - 5 mm for brakes, Ergopower levers, etc.
  - Torque wrench fitted with 8 mm allen key
  - 17 mm hexagonal wrench, for rear hub axle nut
  - 24 mm hexagonal wrench for Daytona/Centaur, Veloce, Mirage bottom bracket tool (UT-BB100 on page 108)
  - M10 x 1 tap for recutting rear derailleur hanger thread
  - TORX wrench to fix the chainrings of the RECORD and CHORUS CARBON 2004 range cranksets

## HEADSET

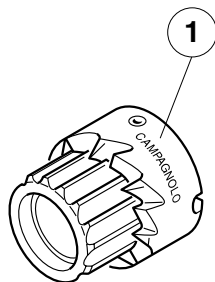

Doppia fresa sedi calotte per attrezzo UT-HS090 (Ø 1")

**UT-HS093:** standard

**UT-HS094:** con inserti in metallo duro

Double cutter cup seats for tool UT-HS090 (Ø 1")

**UT-HS093:** standard

**UT-HS094:** with hard metal inserts

Fraise double pour sièges cuvettes pour outil UT-HS090 (Ø 1")

**UT-HS093:** standard

**UT-HS094:** avec inserts métal dur

Doppelfräser für Gabelkonus für Werkzeug UT-HS090 (Ø 1")

**UT-HS093:** Standard

**UT-HS094:** mit aufgetragenen Hartmetallplättchen

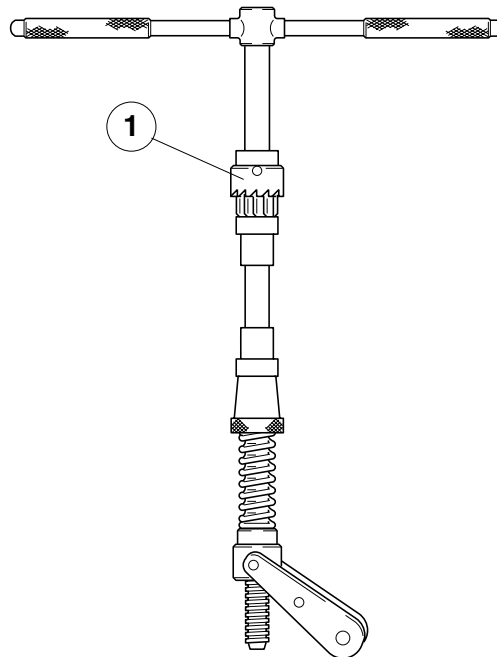

**UT-HS090:** Attrezzo fresatura tubo sterzo, montaggio calotta inferiore e cono superiore serie sterzo 1" - completo di doppia fresa standard (1)

**UT-HS090:** Tool for milling steering tube, for fitting bottom cup and top cone 1" headset - with standard double cutter (1)

**UT-HS090:** Outil pour fraisage tube de direction, montage cuvette inférieure et cône supérieur jeux de directions 1" - avec fraise double standard (1)

**UT-HS090:** Steuersatz-Fräswerkzeug - mit Standard-Doppelfräser (1) - für 1" Steuerschalensitz



## HEADSET

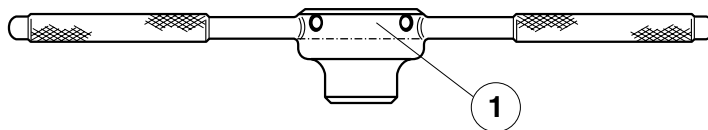

**UT-HS020:** Attrezzo per ripasso filetto forcelle per sterzi 1", con filiera (1)

**UT-HS020:** Tool for recutting fork thread for 1" Headsets, with threader (1)

**UT-HS020:** Outil pour repassage filetage fourche pour jeux de directions 1", avec filière (1)

**UT-HS020:** Werkzeug zum Nachschneiden von Gabelschaftgewinde, mit Gewinde-schneider (1), für Ø 1" Steuersatz

**UT-HS021:** Filiera per attrezzo ripasso forcella UT-HS020 (1")

**UT-HS021:** Cutter for recutting fork thread tool UT-HS020 (1")

**UT-HS021:** Filière pour outil repassage fourche UT-HS020 (1")

**UT-HS021:** Gewindeschneider für Werkzeug UT-HS020 (1") zum Nachschneiden für Gabelschaftrohr

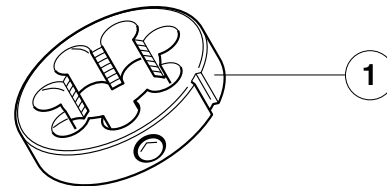

## HEADSET

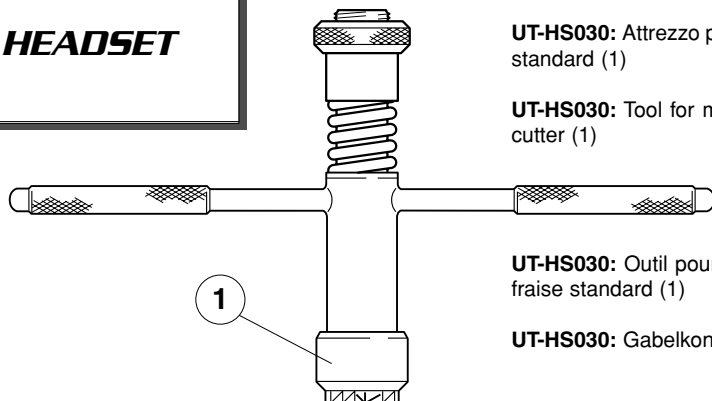

**UT-HS030:** Attrezzo per fresatura sede cono forcella per serie sterzo 1" con fresa standard (1)

**UT-HS030:** Tool for milling fork bottom cone seat for 1" headsets with standard cutter (1)

**UT-HS030:** Outil pour le fraisage siège cône de fourche pour directions 1" avec fraise standard (1)

**UT-HS030:** Gabelkonus-Fräswerkzeug für 1" Steuersitz mit Standardfräser (1)



**UT-HS110:** Attrezzo mont. cono forcella, per s.sterzo Hiddenset 1"  
**UT-HS120:** Attrezzo mont. cono forcella, per s. sterzo Hiddenset 1-1/8"

**UT-HS110:** Tool for installing fork cone, for Ø 1" Hiddenset headset  
**UT-HS120:** Tool for installing fork cone, for Ø 1-1/8" Hiddenset headset

**UT-HS110:** Outil pour montage cône de fourche, pour jeux de directions Hiddenset 1"  
**UT-HS120:** Outil pour montage cône de fourche, pour jeux de directions Hiddenset 1-1/8"

**UT-HS110:** Werkzeug zur Montage von Gabelkonus, für Ø 1" Hiddenset Steuersatz  
**UT-HS120:** Werkzeug zur Montage von Gabelkonus, für Ø 1-1/8" Hiddenset Steuersatz

Fresa per attrezzo UT-HS030 Ø 1"  
**UT-HS031:** standard  
**UT-HS032:** con inserti in metallo duro

Cutter for tool UT-HS030 Ø 1"  
**UT-HS031:** standard  
**UT-HS032:** with hard metal inserts

Fraise pour outil UT-HS030 Ø 1"  
**UT-HS031:** standard  
**UT-HS032:** avec inserts métal dur

Ø 1" Fräser für UT-HS030 Werkzeug  
**UT-HS031:** Standard  
**UT-HS032:** mit aufgetragenen Hartmetallplättchen

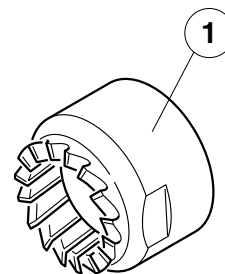

## HEADSET

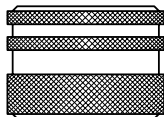

**UT-HS080:** Calibro controllo sede cono forcelle Ø 26,4 mm

**UT-HS080:** Gauge for checking fork cone seat 26,4 mm Ø

**UT-HS080:** Calibre de contrôle siège cône de fourche Ø 26,4 mm

**UT-HS080:** Kontrolllehre für Gabelkonussitz Ø 26,4 mm

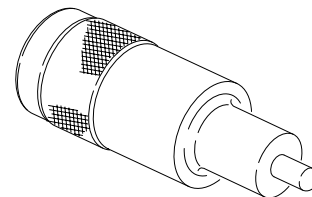

**UT-HS100:** Attrezzo montaggio serie sterzo Ø 1" per cannotto non filettato

**UT-HS100:** Tool for installing Ø 1" headset for unthreaded steerers

**UT-HS100:** Outil pour montage jeu de direction Ø 1" pour tube de fourche non fileté

**UT-HS100:** Werkzeug zur Ø 1" Steuersatzmontage für gewindelosen Gabelschaft

## **HEADSET**

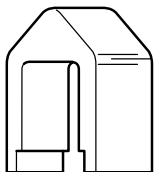

**UT-HS060:** Estrattore cono forcella serie sterzo

**UT-HS060:** Headset crown race remover

**UT-HS060:** Extracteur cône de fourche pour jeux de directions

**UT-HS060:** Abschläger für Gabelkonus für Steuersatz

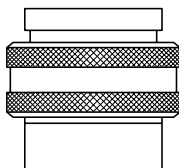

**UT-HS070:** Calibro controllo sedi coni e calotte sterzi 1"

**UT-HS070:** Gauge for checking cone and cup seats 1" headsets

**UT-HS070:** Calibre de contrôle sièges cônes et cuvettes jeux de directions 1"

**UT-HS070:** Kontrollehre für Gabelkonus und 1" Steuerschalensitz

## HEADSET

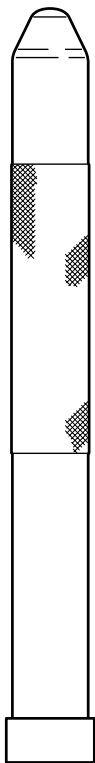

**UT-HS040:** Punzone per montaggio cono forcella, per serie sterzo Ø 1"

**UT-HS040:** Punch for installing fork cone, for Ø 1" headset

**UT-HS040:** Outil pour montage cône de fourche, pour jeux de directions Ø 1"

**UT-HS040:** Aufschläger für Montage von Gabelkonus, für Ø 1" Steuersatz



**UT-HS050:** Estrattore calotta inferiore e cono superiore, per serie sterzo Ø 1"

**UT-HS050:** Extractor for lower headset cup and race, for Ø 1" headset

**UT-HS050:** Extracteur cuvette inférieure et cône supérieur, pour jeux de directions Ø 1"

**UT-HS050:** Austreiber für oberen Konus und untere Lagerschale, für Ø 1" Steuersatz

## ***BOTTOM BRACKET***

**UT-BB045:** Maschio filetto italiano (1 pz.)

**UT-BB046:** Maschio filetto inglese destro (1 pz.)

**UT-BB047:** Maschio filetto inglese sinistro (1 pz.)

**UT-BB045:** Tap for Italian thread (1pc.)

**UT-BB046:** Tap for English thread right-hand (1pc.)

**UT-BB047:** Tap for English thread left-hand (1pc.)

**UT-BB045:** Taraud filetage italien (1 pc.)

**UT-BB046:** Taraud filetage anglais droit (1 pc.)

**UT-BB047:** Taraud filetage anglais gauche (1 pc.)

**UT-BB045:** ITA Gewindeschneider (1 St.)

**UT-BB046:** BSA Gewindeschneider rechts (1 St.)

**UT-BB047:** BSA Gewindeschneider links (1 St.)

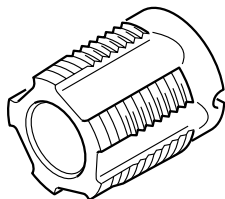

Atrezzo per filettatura scatola movimento centrale con 2 maschi

**UT-BB040:** Filetto italiano

**UT-BB041:** Filetto inglese

Tool for threading bottom bracket housing with 2 taps

**UT-BB040:** Italian thread

**UT-BB041:** English thread

Outil pour le filetage de la boîte de pédalier avec 2 tarauds

**UT-BB040:** filetage italien

**UT-BB041:** filetage anglais

Tretlager-Gewindeschneid-Werkzeug mit 2 Gewindeschneider mit:

**UT-BB040:** ITA Gewinde

**UT-BB041:** BSA Gewinde

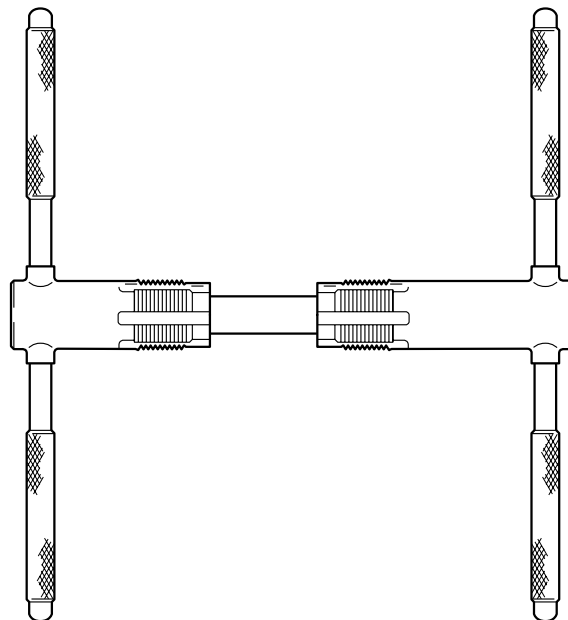

## **BOTTOM BRACKET**

**UT-BB052:** 2 manicotti filettati di guida per attrezzo UT-BB050, italiano

**UT-BB053:** 2 manicotti filettati di guida per attrezzo UT-BB051, inglese

**UT-BB052:** Inner and outer thread guide for UT-BB050, IT thread

**UT-BB053:** Inner and outer thread guide for UT-BB051, BSC thread

**UT-BB052:** 2 manchons filetés de guide pour outils UT-BB050 fil. Italien

**UT-BB053:** 2 manchons filetés de guide pour outils UT-BB051 fil. anglais

**UT-BB052:** 2 Gewindemuffen zur Führung Werkzeuge UT-BB050, ITA

**UT-BB053:** 2 Gewindemuffen zur Führung Werkzeuge UT-BB051, BSA

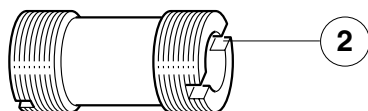

Fresa per attrezzi UT-BB050 e UT-BB051

**UT-BB054:** Fresa standard

**UT-BB055:** Fresa con inserti metallo duro

Cutter for tools UT-BB050 and UT-BB051

**UT-BB054:** standard cutter

**UT-BB055:** cutter with hard metal inserts

Attrezzo fresatura piani scatola movimento centrale con fresa standard (1) e 2 manicotti filettati (2)

**UT-BB050:** Filetto italiano

**UT-BB051:** Filetto inglese

Bottom bracket facing set with standard cutter (1) and 2 - inner and outer - thread guide (2)

**UT-BB050:** Italian thread

**UT-BB051:** English thread

Outil fraisage faces boîte de pédalier avec fraise standard (1) et 2 manchons filetés de guide (2)

**UT-BB050:** filetage italien

**UT-BB051:** filetage anglais

Werkzeug zum Planfräsen des Tretlagergehäuses mit Standardfräse (1) und 2 Gewindemuffen (2)

**UT-BB050:** für ITA Gewinde

**UT-BB051:** für BSA Gewinde

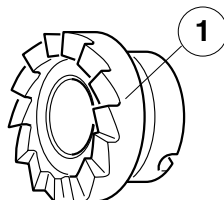
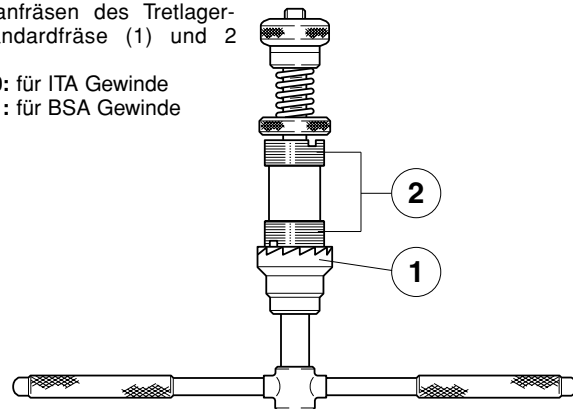

Fresa per attrezzi UT-BB050 e UT-BB051

**UT-BB054:** Fresa standard

**UT-BB055:** Fresa con inserti metallo duro

Cutter for tools UT-BB050 and UT-BB051

**UT-BB054:** standard cutter

**UT-BB055:** cutter with hard metal inserts

## **BOTTOM BRACKET**

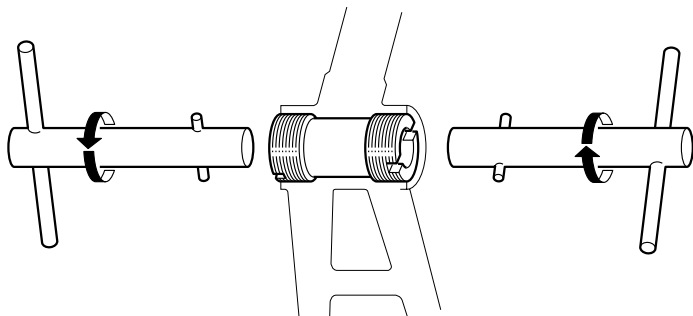

**UT-BB060:** Chiave per montaggio manicotti attrezzi UT-BB050/UT-BB051 (1 pz.)

**UT-BB060:** Key for BB-thread guides UT-BB050/UT-BB051 (1 pcs.)

**UT-BB060:** Clé pour montage guides pour outils UT-BB050/UT-BB051 (1 pcs.)

**UT-BB060:** Rohrschlüssel für Tretlagergewinde-Führungsteile UT-BB050/UT-BB051 (1 Stück)

**UT-BB080** (1 pz.) - **10-UT-BB080** (10 pz.): Chiave per montaggio movimenti centrali CART e ghiera di chiusura pacchi pignoni

**UT-BB080** (1 pz.) - **10-UT-BB080** (10 pz.): Cartridge bottom bracket and sprocket cassette- lock ring remover

**UT-BB080** (1 pz.) - **10-UT-BB080** (10 pz.): Clé pour montage jeux de pédalier CART et roues-libres à cassette

**UT-BB080** (1 pz.) - **10-UT-BB080** (10 pz.): Schlüssel zur Montage von Patronen-Tretlager und Schließring für Freilaufzahnkranz

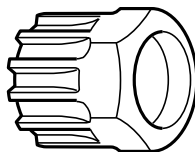



## ***BOTTOM BRACKET***

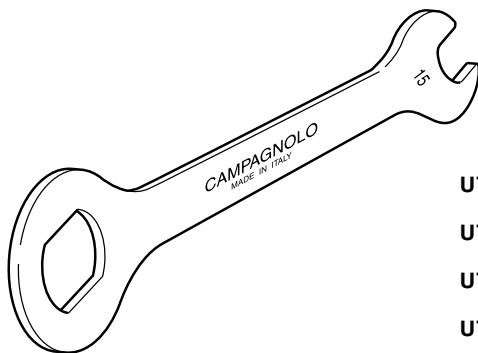

**UT-BB030:** Chiave per calotta destra movimenti centrali e per montaggio pedali

**UT-BB030:** Spanner for bottom bracket right-hand cup and installing pedals

**UT-BB030:** Clé pour cuvette droite jeu de pédalier et montage pédales

**UT-BB030:** Schlüssel für rechte Innenlagerschalen und Pedal-Montage

**UT-BB100:** Utensile per movimenti a cartuccia Daytona/Centaur, Veloce e Mirage

**UT-BB100:** Tool for Daytona/Centaur, Veloce and Mirage cartridge bottom bracket

**UT-BB100:** Clé pour jeux de pédalier à cartouche Daytona/Centaur, Veloce et Mirage

**UT-BB100:** Montageschlüssel für Daytona/Centaur, Veloce und Mirage Patronen-Tretlager

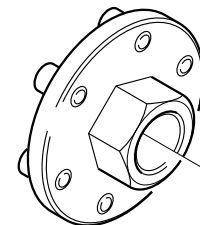

## **HEADSET / BOTTOM BRACKET**



**UT-BB010:** Chiave per serie sterzo Ø 1" e calotta sinistra movimento centrale Pista

**UT-BB010:** Spanner for Ø 1" head sets and Pista bottom bracket left hand cup

**UT-BB010:** Clé pour direction Ø 1" et cuvette réglable jeu de pédalier Pista

**UT-BB010:** Schlüssel für Ø 1" Steuersatz und Stiftschlüssel für Pista Tretlagerschale

**UT-BB011:** Punta per chiave UT-BB010

**UT-BB011:** Pin for UT-BB010

**UT-BB011:** Grain pour clé UT-BB010

**UT-BB011:** Stift für Schlüssel UT-BB010

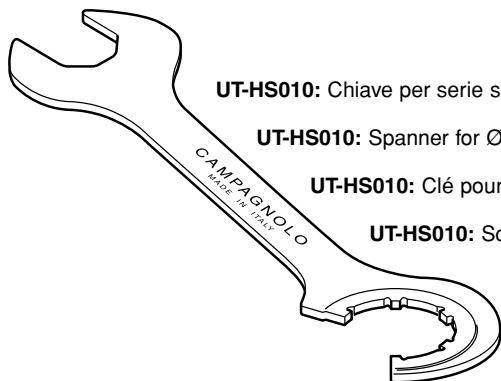

**UT-HS010:** Chiave per serie sterzo Ø 1" e contranello movimento centrale Pista

**UT-HS010:** Spanner for Ø 1" head sets and Pista bottom bracket counter ring

**UT-HS010:** Clé pour direction Ø 1" et contre-écrou du jeu de pédalier Pista

**UT-HS010:** Schlüssel für Ø 1" Steuersatz und Pista Tretlager-Konterring

## FRAME PREPARATION

**UT-VS060:** Maschio M3 x 0,5 per ripasso filetti forcellini per viti registrazione

**UT-VS060:** M3 x 0,5 tap for recutting rear drop-out threads for setting screws

**UT-VS060:** Taraud M3 x 0,5 pour repassage filetage pattes de cadre pour vis de réglage

**UT-VS060:** M3 x 0,5 Gewindebohrer zum Nachschneiden von Stellschraubengewinde im Ausfallende

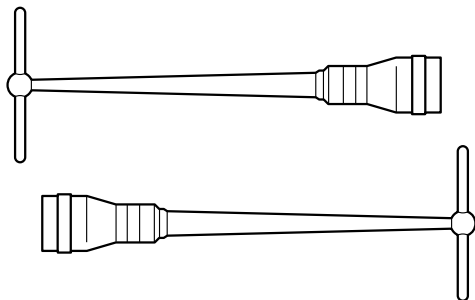
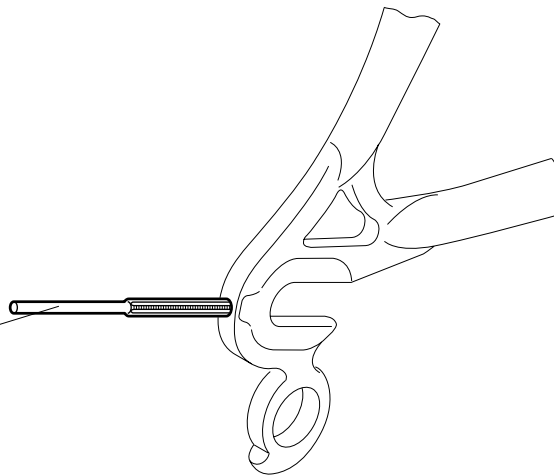

**UT-VS120:** Calibro per controllo allineamento forcellini e punte forcelle (2 pz.)

**UT-VS120:** Drop-out alignment set (2 pcs.)

**UT-VS120:** Calibre pour contrôle alignement pattes de cadres et pattes de fourches (2 pcs.)

**UT-VS120:** Werkzeug zum Ausrichten von Gabel- und Ausfallenden (2 St.)

## **FRAME PREPARATION**

**UT-VS050:** Maschio M5 x 0,8 per ripasso filetti attacchi quadri comandi e attacchi borracce

**UT-VS050:** M5 x 0,8 tap for recutting shifting lever- and bottle cage threads

**UT-VS050:** Taraud M5 x 0,8 pour repassage filetage plots de manettes et attaches bidons

**UT-VS050:** M5 x 0,8 Gewindebohrer zum Nachschneiden der Gewinde für Schalthebel und Trinkflaschenhalter

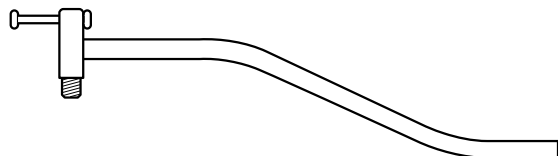
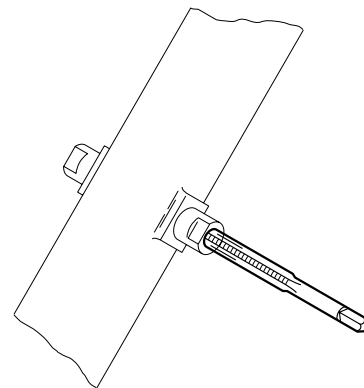

**UT-VS030:** Riscontro allineamento occhiello attacco cambio

**UT-VS030:** Rear derailleur hanger alignment tool

**UT-VS030:** Calibre de contrôle attache de dérailleur arrière

**UT-VS030:** Richtwerkzeug zur Kontrolle von Ausfallende mit Schaltauge

## **CRANKS / CHAINRINGS**

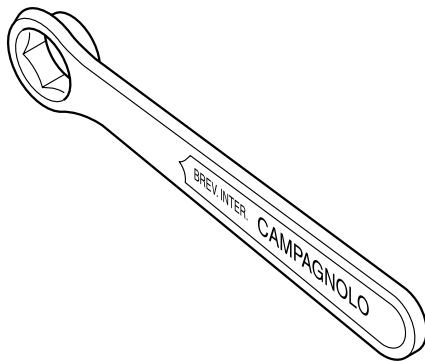

**UT-FC050:** Chiave con esagono da 15 mm per estrattore pedivelle

**UT-FC050:** 15 mm crank bolt spanner

**UT-FC050:** Clé avec hexagone de 15 mm pour extracteur manivelles

**UT-FC050:** 15 mm Schlüssel für Tretkurbelabzieher

**UT-FC060:** Estrattore pedivelle standard

**UT-FC070:** Estrattore pedivelle con filetto a sinistra

**UT-FC060:** Extractor for standard cranks

**UT-FC070:** Extractor for cranks with l.h. thread

**UT-FC060:** Extracteur manivelles standards

**UT-FC070:** Extracteur manivelles avec filetage à gauche

**UT-FC060:** Standard - Tretkurbelabzieher

**UT-FC070:** Tretkurbelabzieher mit Linksgewinde

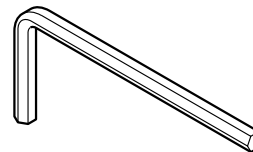
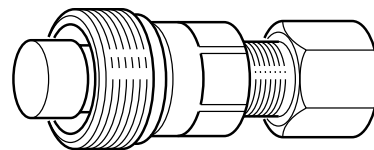

**UT-FC030:** Chiave a brugola da 5 mm

**UT-FC030:** 5 mm allen key

**UT-FC030:** Clé à pans creux de 5 mm

**UT-FC030:** 5 mm L-Schlüssel

**CRANKS /  
CHAINRINGS /  
BRAKES**

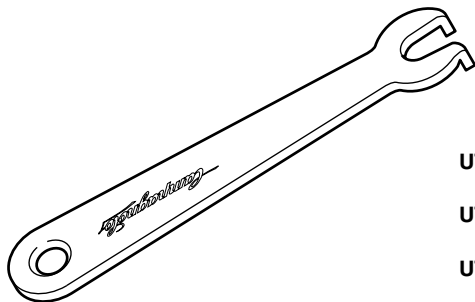

**UT-FC040:** Chiave per dadi fissaggio ingranaggi

**UT-FC040:** Spanner for chainring retaining nuts

**UT-FC040:** Clé pour écrous de fixation plateaux de pédaliers

**UT-FC040:** Schlüssel zur Befestigung von Kettenblattbolzen

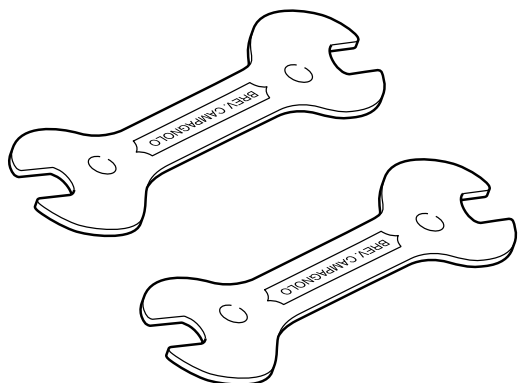

**UT-BR010:** Coppia chiavi 13-14 per registrazione freni e coni mozzi

**UT-BR010:** Pair of 13-14 mm spanners for adjusting brakes and hub cones

**UT-BR010:** Paire clés 13-14 pour réglage freins et cônes de moyeux

**UT-BR010:** 13-14 mm Schlüssel (2 Stücke) zum Einstellen von Bremsen und Nabelkonusen

## HUBS & WHEELS

**UT-HU090:** Attrezzo per montaggio cricchetti ruota libera su mozzi standard e HPW

**UT-HU090:** freewheel-pawl assembling tool (standard and HPW-hubs)

**UT-HU090:** Outil pour montage cliquets de roue-libre sur moyeux standard et HPW

**UT-HU090:** Werkzeug zur Montage der Kassettenkörper-Sperrklinken (Standard- und HPW-Nabe)

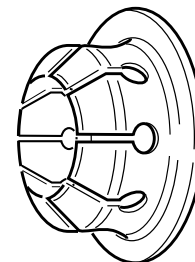

**UT-HU020:** Pinza per perni filettati mozzi

**UT-HU020:** Hub axle vise

**UT-HU020:** Pince pour axes filetés de moyeux

**UT-HU020:** Klemmvorrichtung für Naben-Achsgewinde

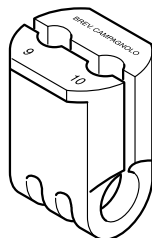

**UT-HU050:** Tiraraggi

**UT-HU050:** Spoke wrench

**UT-HU050:** Clé à rayons

**UT-HU050:** Speichenschlüssel

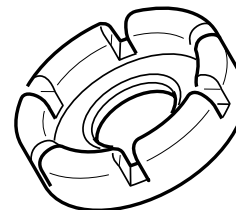

## HUBS & WHEELS

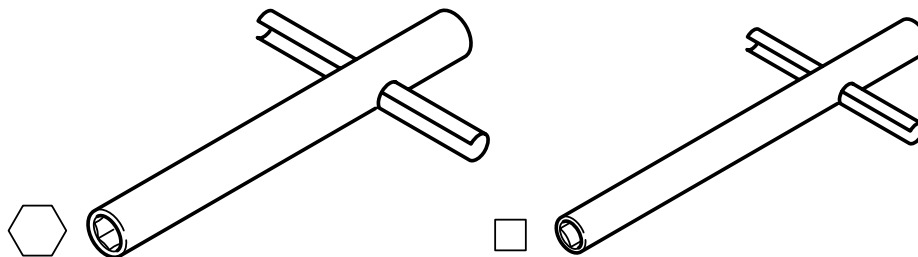

**UT-HU070:** Chiave per raggi ruote Shamal, Vento e Zonda (fino a gamma '98 - per gamma '99 e successive vedi pag. 98)

**UT-HU070:** Shamal, Vento and Zonda wheel truing tool (till '98 range - from '99 range see page 98)

**UT-HU070:** Clé à rayons pour roues Shamal, Vento et Zonda (jusqu'à la gamme '98 - pour la gamme '99 et suivantes v. page 98)

**UT-HU070:** Nippelspanner für Shamal, Vento und Zonda (bis '98 Produktlinie - ab '99 Produktlinie siehe S. 98)

**UT-HU060:** Chiave per raggi ruote Bora

**UT-HU060:** Bora wheel truing tool

**UT-HU060:** Clé à rayons pour roues Bora

**UT-HU060:** Vierkant-Nippelspanner für Bora



## **HUBS & WHEELS**

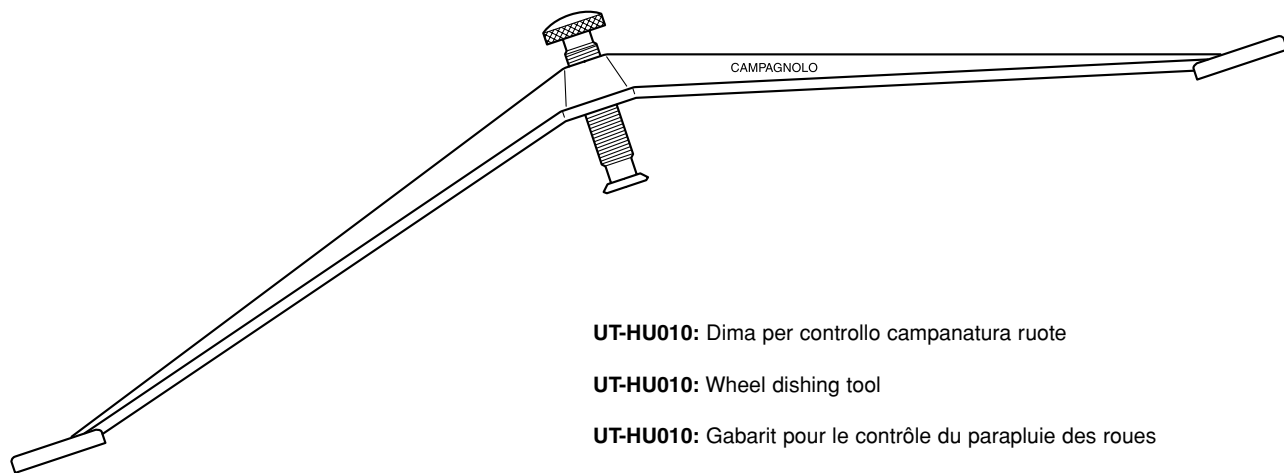

**UT-HU010:** Dima per controllo campanatura ruote

**UT-HU010:** Wheel dishing tool

**UT-HU010:** Gabarit pour le contrôle du parapluie des roues

**UT-HU010:** Zentrierbügel

## **SPROCKETS / CHAIN**

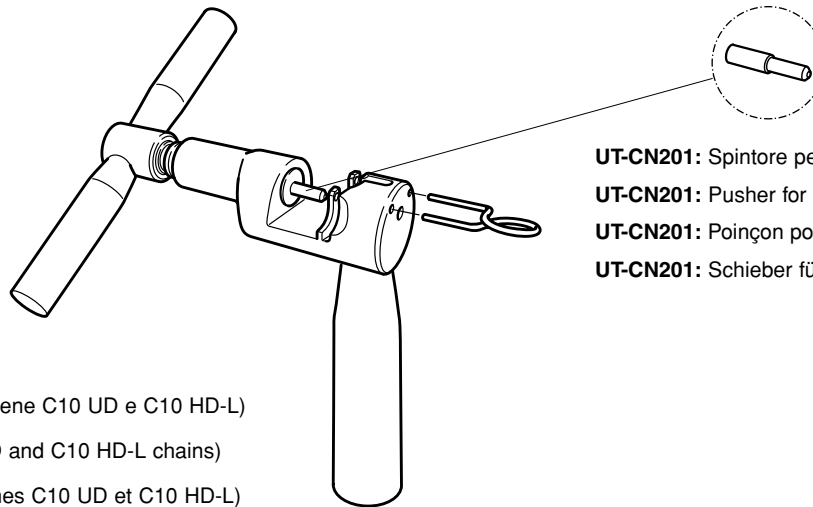

**UT-CN201:** Spintore per UT-CN200

**UT-CN201:** Pusher for UT-CN200

**UT-CN201:** Poinçon pour UT-CN200

**UT-CN201:** Schieber für UT-CN200

**UT-CN200:** Utensile per **HD-Link** (catene C10 UD e C10 HD-L)

**UT-CN200:** Tool for **HD-Link** (C10 UD and C10 HD-L chains)

**UT-CN200:** Outil pour **HD-Link** (chaînes C10 UD et C10 HD-L)

**UT-CN200:** Werkzeug für **HD-Link** (C10 UD und C10 HD-L Ketten)

**UT-CS060:** Chiave con catena 10s per smontaggio pignoni 10s, 9s e 8s

**UT-CS060:** Spanner with 10s chain for 10, 9 and 8s sprockets

**UT-CS060:** Fouet à chaîne 10s pour pignons 10s, 9s et 8s

**UT-CS060:** Zahnkranzabnehmer mit Rennkette 10s für 10-, 9- und 8s Ritzeln

**ITALY - Central Service Center****CAMPAGNOLO SRL HEADQUARTERS**

Via della Chimica, 4 - 36100 VICENZA

Phone: +39-0-444-225605

Fax: +39-0-444-225400

E-mail: service@campagnolo.com

**AUSTRALIA****BIKE SPORTZ IMPORTS PTY LTD**

23c-23d Industrial Drive,

Braeside, Victoria 3195 NSW

Phone: +61-3-95861600

Fax: +61-3-98576951

**CYCLING PROJECTS**

80 King Street,

NSW 2193 Ashbury

Phone: +61-2-97992407

Fax: +61-2-97879940

**AUSTRIA****CAMPAGNOLO DEUTSCHLAND GMBH**

An der Schusterinsel, 15

51379 LEVERKUSEN - DEUTSCHLAND

Phone: +49-2171-724320

Fax: +49-2171-724315

**BENELUX****CARD BENELUX BV**

Vaartveld 19 - 4704 SE ROOSENDAAL

Netherlands

Phone: +31-165-564241

Fax: +31-165-563248

**BENELUX (continued)****FA. WOUT VERHOEVEN**

Rodenrijseweg 409 -

2651 AM BERKEL EN RODENRIJS - Netherlands

Phone: +31-10-5115014

Fax: +31-10-5117708

**I.C.C. - INTERNATIONAL CYCLE CONNECTION**

Weststraat 42 - P.O. Box 73

4527 ZH AARDENBURG - Netherlands

Phone: +31-117-492820

Fax: +31-117-492835

**CANADA****CYCLES MARINONI INC**

1067, Levis - LACHENAIE - QUEBEC J6W 4L2

Phone: +1-450-4717133

Fax: +1-450-4719887

**GREAT WESTERN BICYCLE CO. LTD.**

233 West Broadway

VANCOUVER BC V5Y 1P5

Phone: +1-604-8722424

Fax: +1-604-87202226

**CZECH REPUBLIC****KOLA SIRER**

P.O. Box 107 - 26601 BEROUN 1

Phone: 00420-311-621355

Fax: 00420-311-625492

**DENMARK****MARKER SCANDINAVIA**

Industrivej 1D - DK-4000

Roskilde - DENMARK

Phone: +45-70228075

Fax: +45-46498088

**FINLAND****MARKER SCANDINAVIA**

Industrivej 1D - DK-4000

Roskilde - DENMARK

Phone: +45-70228075

Fax: +45-46498088

**VELOSPORT KY**

Mäkelänkatu, 95 - 00610 HELSINKI P

Phone: +358-9-7571377

Fax: +358-9-795498

**FRANCE****CAMPAGNOLO FRANCE**

42160 ANDREZIEUX - BOUTHEON CEDEX

Phone: +33-477-556305

Fax: +33-477-556345

**GERMANY****CAMPAGNOLO DEUTSCHLAND GMBH**

An der Schusterinsel, 15

51379 LEVERKUSEN

Phone: +49-2171-724320

Fax: +49-2171-724315

**GREECE****CYCLES FIDUSA**

Th. Sofuli 97 - 85100 RHODOS

Phone: +30-241-021264

Fax: +30-241-021519

**JAPAN****KAWASHIMA CYCLE SUPPLY CO.**

No. 3-3-16 Kitasho-cho, Sakai,

Osaka, 590-0007

Phone: +81-722-38-6126

Fax: +81-722-21-4379

---

**JAPAN** (continued)

---

**NICHINAO SHOKAI CO., LTD**

6-16-8, Sotokanda, Chiyodaku - TOKYO 101  
Phone: +81-3-38326251  
Fax: +81-3-38326266

---

**NEW ZEALAND**

---

**WH WORRALL CO. LTD.**

43 Felix St./Penrose - P.O. Box 12481  
AUCKLAND  
Phone: +64-9-6360641  
Fax: +64-9-6360631

---

**NORWAY**

---

**MARKER SCANDINAVIA**

Industrivej 1D - DK-4000  
Roskilde - DENMARK  
Phone: +45-70228075  
Fax: +45-46498088

---

**SOUTH AFRICA**

---

**CYCLING J&J (PTY) LTD**

169 Meerlust Street - Willow Glen  
PRETORIA  
Phone: +27-012-8075570  
Fax: +27-012-8074267

---

**SPAIN**

---

**CAMPAGNOLO IBERICA S.L.**

Avda. de Los Huetos 46 Pab. 31 - 01010  
VITORIA  
Phone: +34-945-217195  
Fax: +34-945-217198

---

**SWEDEN**

---

**MARKER SCANDINAVIA**

Industrivej 1D - DK-4000  
Roskilde - DENMARK  
Phone: +45-70228075  
Fax: +45-46498088

**RACERDEPAN**

Odengatan, 38 - 52141 FALKÖPING  
Phone: +46-515711430  
Fax: +46-51559430

---

**SWITZERLAND**

---

**PIERO ZURINO AG**

Flawilerstrasse 3a  
9500 WIL SG  
Phone: +41-71-9236001  
Fax: +41-71-9236353

**U.G.D. SPORT DIFFUSION S.A.**

La Taille - 2053 CERNIER  
Phone: +41-32-8536363  
Fax: +41-32-8536464

---

**UNITED KINGDOM**

---

**ITALIAN CYCLE PRODUCTS LIMITED**

Unit 3, Napoleon Business Park  
Wheterby Road - DERBY - DE24 8HL  
Phone: +44-01332-371176  
Fax: +44-01332-371179

---

**UNITED STATES**

---

**CAMPAGNOLO USA INC.**

2105-L Camino Vida Roble  
CARLSBAD - CA 92009  
Phone: +1-760-9310106  
Fax: +1-760-9310991

**OCHSNER INT. INC**

246 E. Marquardt Drive - WHEELING  
Il. 60090-6430  
Phone: +1-847-4658200  
Fax: +1-847-4658282

**QUALITY BICYCLES PRODUCTS**

6400 W. 105th Street - BLOOMINGTON,  
MN 55438-2554  
Phone: +1-952-941-9391  
Fax: +1-952-941-9799

### **Avviso Importante su PRESTAZIONI, SICUREZZA E GARANZIA**

I componenti delle trasmissioni 9s e 10s, gli impianti frenanti, e la maggior parte dei componenti Campagnolo®, sono progettati come un unico sistema integrato. Per non compromettere la SICUREZZA, le PRESTAZIONI, la LONGEVITA', la FUNZIONALITA' e per non invalidare la GARANZIA, vi raccomandiamo di utilizzare **esclusivamente** i componenti specificati dalla Campagnolo Srl, senza interfacciarli o sostituirli con prodotti fabbricati da altre aziende.

### **Important PERFORMANCE, SAFETY and WARRANTY Notice**

The components of the 9s and 10s drivetrains, the braking systems, and most Campagnolo® components, are designed as a single integrated system. To avoid compromises in terms of SAFETY, PERFORMANCE, DURABILITY, FUNCTION, and to prevent voiding the WARRANTY, we recommend that you **only** use the components specified by Campagnolo Srl, without interfacing them with or substituting them with products manufactured by other companies.

### **Notice important sur PERFORMANCES, SECURITE ET GARANTIE**

Les composants des transmissions 9s et 10s, les freins et la plus part des composants Campagnolo®, sont projetés come un seul système intégré. Pour ne pas compromettre la SECURITE, les PERFORMANCES, la LONGEVITE, la FONCTIONNALITE et pour ne pas invalider la GARANTIE, on vous recommande **de n'utiliser que** les composants spécifiés par Campagnolo Srl, sans les relier avec ou les remplacer par des produits fabriqués par d'autres sociétés.

### **Wichtiger Hinweis zu PRODUKTLEISTUNG, SICHERHEIT und GARANTIE**

Die Komponenten der 9s und 10s Antriebssysteme, des Bremssystems, sowie Großteil der von Campagnolo® hergestellten Komponenten, wurden als Bestandteile eines integrierten Systems entwickelt. Um die SICHERHEIT, die LEISTUNG, die DAUER, die FUNKTIONSTÜCHTIGKEIT und die GARANTIE nicht zu beeinträchtigen, empfehlen wir den **ausschließlichen** Gebrauch der von Campagnolo Srl spezifizierten Bestandteile und diese nicht mit Produkten anderer Hersteller zu ersetzen oder zu kombinieren.

### **Avviso Importante sobre PRESTACIONES, SEGURIDAD Y GARANTÍA.**

Los componentes de las transmisiones 9s y 10s, los sistemas de frenado, y la mayor parte de componentes Campagnolo®, han sido ideados como un único sistema integrado. Con el fin de no comprometer la SEGURIDAD, las PRESTACIONES, la LONGEVIDAD, la FUNCIONALIDAD y no invalidar la GARANTÍA, os aconsejamos utilizar **exclusivamente** los componentes especificados por Campagnolo Srl, sin combinarlos o sustituirlos con productos fabricados por otras empresas.

Campagnolo, Campy, Record, Chorus, EPS, Centaur, Centaur Century Grey, Veloce, Mirage, Xenon, Hyperon, Hyperon Ultra, Neutron, Proton, Eurus, Zonda, Scirocco, Bora, Ghibli, Vento, Pista, Ergobrain, Ergobrain10, Superlative, Ultra, Floating-Link-Action, HD-Link, HD-L, Exa-Drive, Ultra-Drive, Pro-Fit, Pro-Fit PLUS, Differential brakes, Threadless, Hiddenset, Hiddenset TTC, TTC, Ergopower, BB System, C10, C9, ED, UD, HPW, G3, Ultralinear-Geometry, Ultralinear, Differential rims, Differential spokes, Asymmetric, AC-H, AC-S, SC-S, Pro-Shop, Tecnologia ed Emozione are Campagnolo Srl Trademarks.



# CAMPAGNOLO IN THE WORLD

## ITALY

CAMPAGNOLO S.R.L.

Via della Chimica, 4 • 36100 Vicenza • ITALY

Phone: +39-0444-225500 • Fax: +39-0444-225400

## FRANCE

CAMPAGNOLO FRANCE SARL

Rue Jean Autelin • B.P. 148 • 42160 Andrézieux • Bouthéon

Cedex • FRANCE

Phone: +33-477-556305 • Fax: +33-477-556345

## GERMANY

CAMPAGNOLO DEUTSCHLAND GMBH

An der Schusterinsel 15 • 51379 Leverkusen • GERMANY

Phone: +49-2171-72430 • Fax: +49-2171-724315

## SPAIN

CAMPAGNOLO IBERICA S.L.

Avda. de Los Huetos 46 Pab. 31 • 01010 Vitoria • SPAIN

Phone: +34-945-217195 • Fax: +34-945-217198

## UNITED STATES

CAMPAGNOLO USA INC.

2105-L Camino Vida Roble • Carlsbad CA 92009 • U.S.A.

Phone: +1-760-9310106 • Fax: +1-760-9310991

## SERVICE AND TECHNICAL INFORMATION:

### ITALY (CENTRAL)

Technical Information: Phone: +39-0444-225600 •

Fax: +39-0444-225400

Service Center: Phone: +39-0444-225605 •

Fax: +39-0444-225400

### FRANCE

Phone: +33-477-554449 • Fax: +33-477-556345

### GERMANY

Phone: +49-2171-724320 • Fax: +49-2171-724315

### SPAIN

Phone: +34-945-217195 • Fax: +34-945-217198

### U.S.A.

Phone: +1-760-9310106 • Fax: +1-760-9310991

## AGENCIES

### AUSTRALIA

CYCLING PROJECTS

80 King Street • NSW 2193 Ashbury • AUSTRALIA •

Tel. +61-2-97992407 • Fax +61-2-97879940

### BENELUX

INTERNATIONAL CYCLE CONNECTION • I.C.C. • Weststraat 42

P.O. Box 73 • 4527 ZH Aardenburg • NEDERLAND •

Tel. +31-11-7492820 • Fax +31-11-7492835

### BULGARIA • CZECH REPUBLIC • POLAND • RUMANIA

SLOVAKIAN REPUBLIC • SLOVENIA • HUNGARY

FIRMA GALLIZIA

10. Oktoberstraße 7 • 9800 Spittal/Drau • AUSTRIA •

Tel. +43-4762/2275 • Fax +43-4762/2275

### DENMARK • SWEDEN • NORWAY • FINLAND

MARKER SCANDINAVIA

Industrivej 1D • DK-4000 ROSKILDE • DENMARK •

Tel.: +45-70228075 • Fax: +45-46498088

### RUSSIA

VLADISLAV BOBRIK

Mob.: 335 7847758 and 339 1814329 - E-mail: bobrik@libero.it

### SOUTH AMERICA AND MEXICO

GEORGE PANARA

Sao Paulo - BRASIL - Tel.: +55 11 4436 9123 - Fax: +55 11 4436 12 13

### TAIWAN • MAINLAND CHINA • VIETNAM

COLMAX INTERNATIONAL LTD

2F, No.23 Lane 229 • Kuang Hwa Street • Tainan • TAIWAN

Tel. +886-6-2361683 • Fax +886-6-2361681

### UNITED KINGDOM

SELECT CYCLE COMPONENTS

Unit 3, Napoleon Business Park • Wheterby Road • DERBY • DE24 8HL

Tel. +44-0780260628 • Fax +44-1949-829039