

GHIERE LOCKRINGS

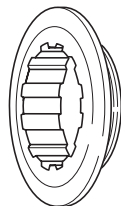

ECROUS VERSCHLUSSRING

CODE / CODICE	TYPE / TIPO		RANGE / GAMMA	HUB COMPATIBILITY / COMPATIBILITA' MOZZI
CS-401	9 Speed "oversize" thread / fil.: 27 x 1	steel/acciaio	1999	RECORD - CHORUS all wheels / tutte le ruote
CS-501	9 Speed "oversize" thread / fil.: 27 x 1	steel/acciaio (for Z.11)	1999	RECORD - CHORUS all wheels / tutte le ruote
CS-101T	9 Speed "oversize" thread / fil.: 27 x 1	titanium/titanio	1999	RECORD - CHORUS all wheels / tutte le ruote
CS-201	9 Speed thread / fil.: 26 x 1	steel/acciaio	1999	ATHENA - VELOCE - MIRAGE
			1998 / 1997	9 Speed groups / gruppi 9 Speed 9 Speed wheels / ruote 9 Speed
CS-301	9 Speed thread / fil.: 26 x 1	steel/acciaio (for Z.11)	1999	ATHENA - VELOCE - MIRAGE
			1998 / 1997	9 Speed groups / gruppi 9 Speed 9 Speed wheels / ruote 9 Speed
CS-001T	9 Speed thread / fil.: 26 x 1	titanium/titanio	1999	ATHENA - VELOCE - MIRAGE
			1998 / 1997	9 Speed groups / gruppi 9 Speed 9 Speed wheels / ruote 9 Speed '97 8 Speed aluminum freewheel body / corpetto RL in alluminio 8 Speed '97
CS-001V	8 Speed thread / fil.: 29 x 1	steel/acciaio	1999 and previous 1999 e precedenti	all 8 Speed hubs (with steel freewheel body) tutti i mozzi 8 Speed (con corpetto RL in acciaio)

RECORD MK2
9 SPEED
CS-29RE

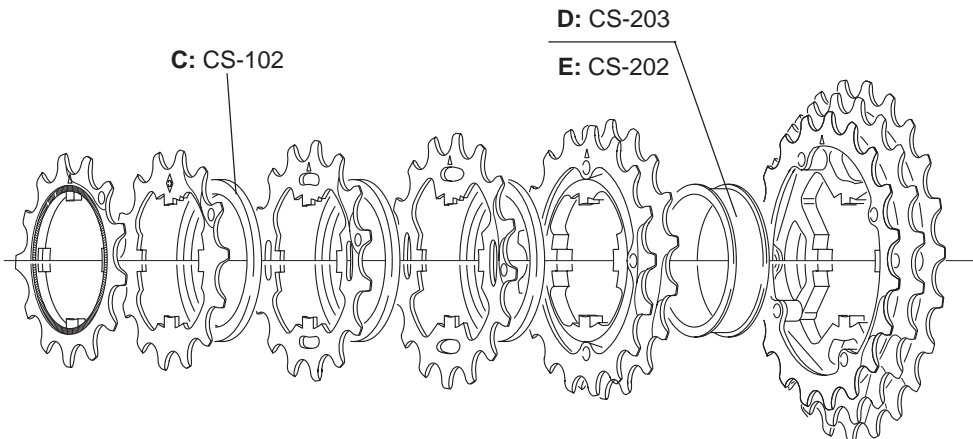

11 - 21	11A-1° 9S-011	12A-2° 9S-121	C	13A 9S-131	C	14A 9S-141	C	15A 9S-151	C	16A-17A* 9S-670	E	19A-21A* 9S-91AT
11 - 23	11B-1° 9S-012	12B-2° 9S-122	C	13B 9S-132	C	14B 9S-142	C	15B 9S-152	C	17B-19A* 9S-79B	E	21A-23A* 9S-130T
12 - 21	12A-1° 9S-113	13A 9S-131	C	14A 9S-141	C	15A 9S-151	C	16A-17A-18C* 9S-678	D	19C-21C* 9S-91CT		
12 - 23	12A-1° 9S-113	13A 9S-131	C	14A 9S-141	C	15A 9S-151	C	16A-17A* 9S-670	D	19A-21A-23A* 9S-913AT		
13 - 23	13A-1° 9S-114	14A 9S-141	C	15A 9S-151	C	16A 9S-161	C	17A-18C* 9S-780	D	19C-21C-23C* 9S-913CT		
13 - 26	13A-1° 9S-114	14A 9S-141	C	15A 9S-151	C	16A 9S-161	C	17A-19A* 9S-79A	D	21A-23A-26A* 9S-136T		

* pre-assembled

**RECORD
TITANIUM
MK2 9 SPEED
CS-29RETI**

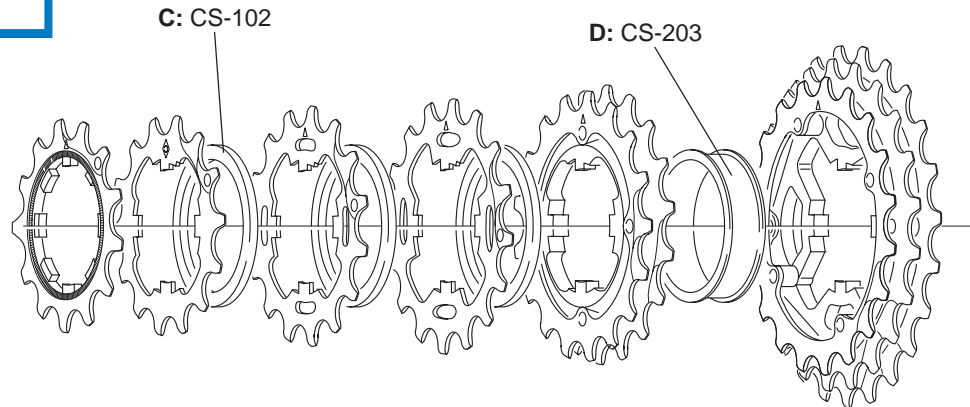

12 - 21	12A-1°	13A	C	14A	C	15A	C	16A-17A-18C*	D	19C-21C*
	9S-012T	9S-131T		9S-141T		9S-151T		9S-678T		9S-91CT
12 - 23	12A-1°	13A	C	14A	C	15A	C	16A-17A*	D	19A-21A-23A*
	9S-012T	9S-131T		9S-141T		9S-151T		9S-670T		9S-913AT
13 - 23	13A-1°	14A	C	15A	C	16A	C	17A-18C*	D	19C-21C-23C*
	9S-013T	9S-141T		9S-151T		9S-161T		9S-780T		9S-913CT
13 - 26	13A-1°	14A	C	15A	C	16A	C	17A-19A*	D	21A-23A-26A*
	9S-013T	9S-141T		9S-151T		9S-161T		9S-79AT		9S-136T

* pre-assembled

CHORUS MK2
9 SPEED
CS-09CH
ATHENA MK2
9 SPEED
CS-09AT

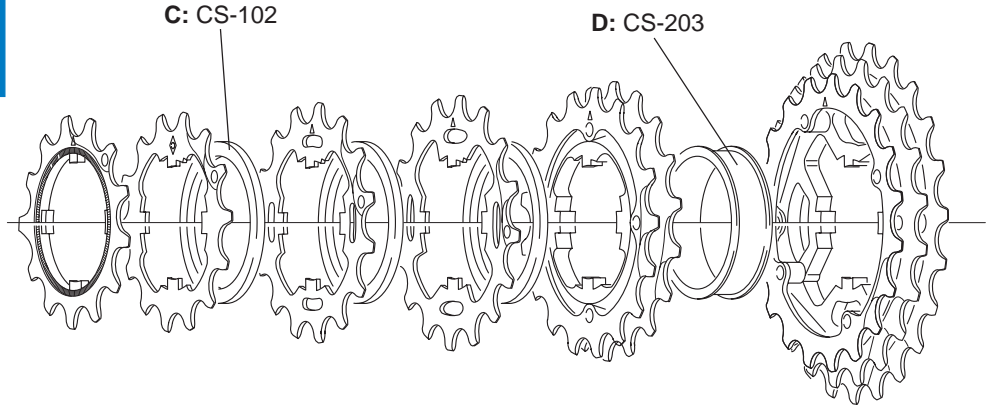

12 - 21	12A-1°	13A	C	14A	C	15A	C	16A-17A-18C*	D	19C-21C*
	9S-113	9S-131		9S-141		9S-151		9S-678		9S-91C
12 - 23	12A-1°	13A	C	14A	C	15A	C	16A-17A*	D	19A-21A-23A*
	9S-113	9S-131		9S-141		9S-151		9S-670		9S-913A
13 - 23	13A-1°	14A	C	15A	C	16A	C	17A-18C*	D	19C-21C-23C*
	9S-114	9S-141		9S-151		9S-161		9S-780		9S-913C
13 - 26	13A-1°	14A	C	15A	C	16A	C	17A-19A*	D	21A-23A-26A*
	9S-114	9S-141		9S-151		9S-161		9S-79A		9S-136

* pre-assembled

**VELOCE
9 SPEED
CS-09VL**

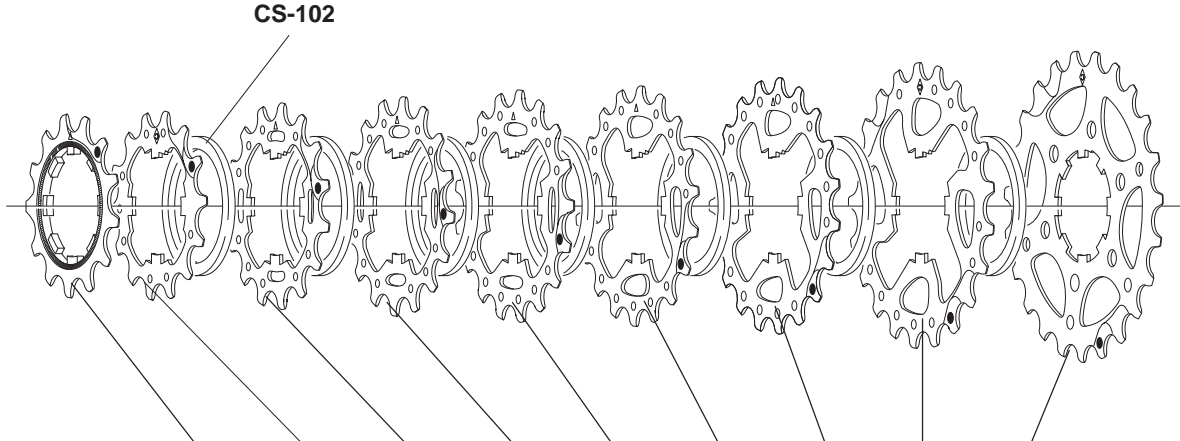

11 - 23	11B-1P 9S-012	12B 9S-022	13B 9S-132	14B 9S-142	15B 9S-152	17B 9S-172	19A 9S-191	21A 9S-211	23A 9S-231
12 - 23	12A-1P 9S-013	13A 9S-131	14A 9S-141	15A 9S-151	16A 9S-161	17A 9S-171	19A 9S-191	21A 9S-211	23A 9S-231
13 - 23	13A-1P 9S-014	14A 9S-141	15A 9S-151	16A 9S-161	17A 9S-171	18C 9S-183	19C 9S-193	21C 9S-213	23C 9S-233
13 - 26	13A-1P 9S-014	14A 9S-141	15A 9S-151	16A 9S-161	17A 9S-171	19A 9S-191	21A 9S-211	23A 9S-231	26A 9S-261

**MIRAGE
9 SPEED
CS-09MI**

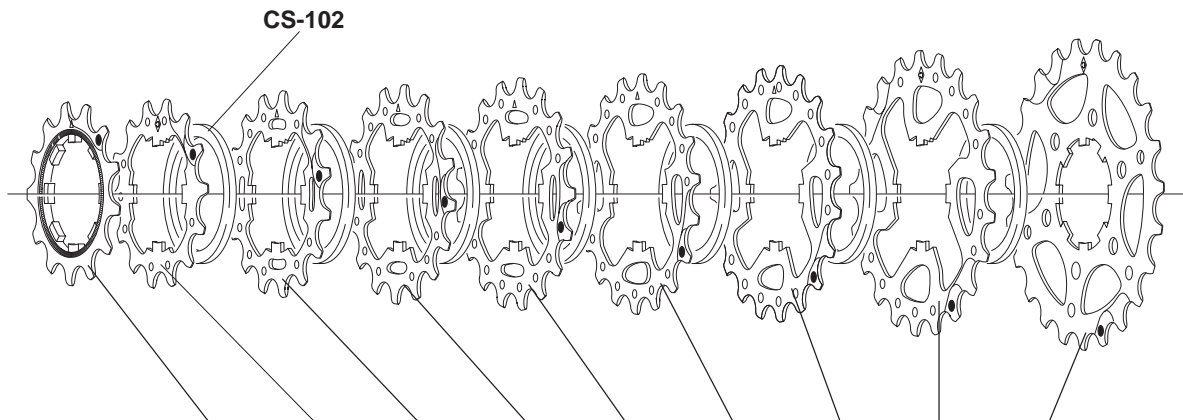

12 - 23	12A-1P	13A	14A	15A	16A	17A	19A	21A	23A
	9S-013Z	9S-131Z	9S-141Z	9S-151Z	9S-161Z	9S-171Z	9S-191Z	9S-211Z	9S-231Z
13 - 23	13A-1P	14A	15A	16A	17A	18C	19C	21C	23C
	9S-014Z	9S-141Z	9S-151Z	9S-161Z	9S-171Z	9S-183Z	9S-193Z	9S-213Z	9S-233Z
13 - 26	13A-1P	14A	15A	16A	17A	19A	21A	23A	26A
	9S-014Z	9S-141Z	9S-151Z	9S-161Z	9S-171Z	9S-191Z	9S-211Z	9S-231Z	9S-261Z

8 SPEED CS-08SP

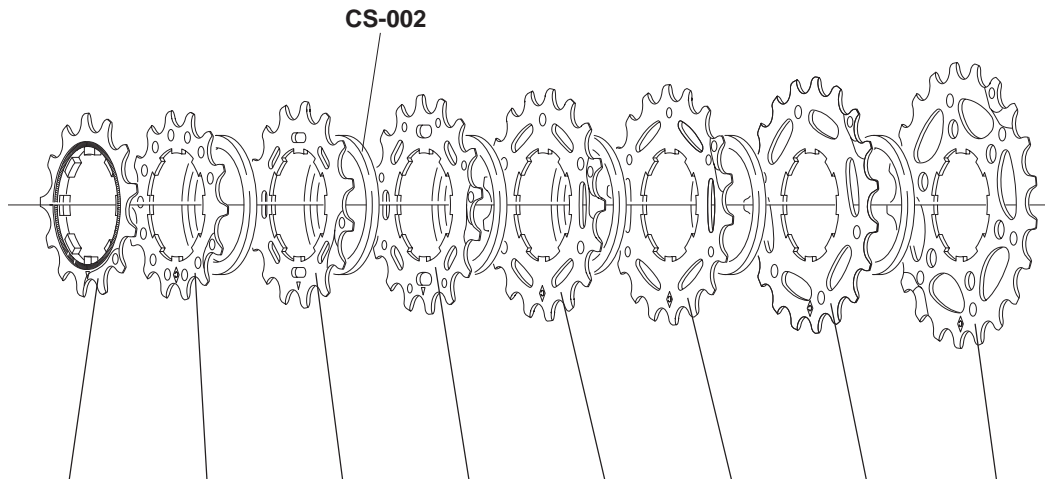

12 - 23	12B-1P CS-004V	13B CS-132V	14B CS-142V	15B CS-152V	17B CS-172V	19A CS-191V	21A CS-211V	23A CS-231V
13 - 23	13A-1P CS-005V	14A CS-141V	15A CS-151V	16A CS-161V	17A CS-171V	19A CS-191V	21A CS-211V	23A CS-231V
13 - 26	13B-1P CS-006V	14B CS-142V	15B CS-152V	17B CS-172V	19A CS-191V	21A CS-211V	23A CS-231V	26A CS-261V

**RECORD PRO-FIT
PEDALS
PD-52REQR**

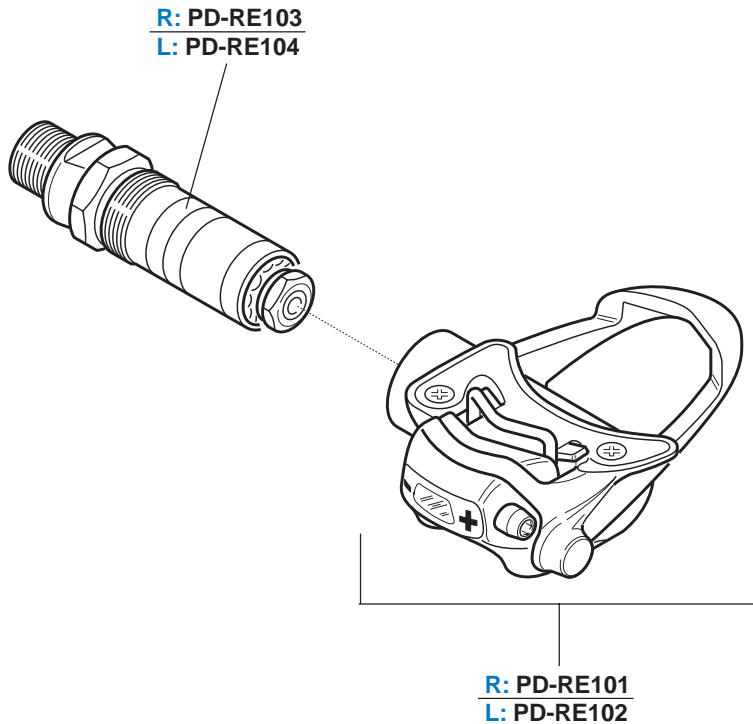

**CHORUS PRO-FIT
PEDALS
PD-42CHQR**

R: PD-CH103
L: PD-CH104

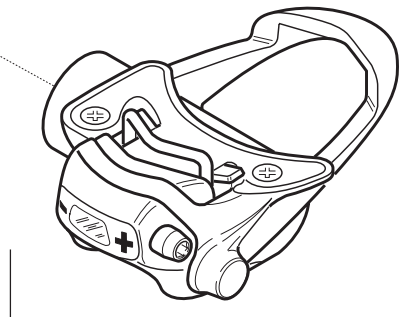
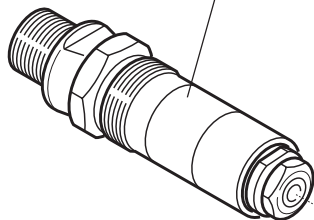

R: PD-CH101
L: PD-CH102

**VELOCE PRO-FIT
PEDALS
PD-32VLQR**

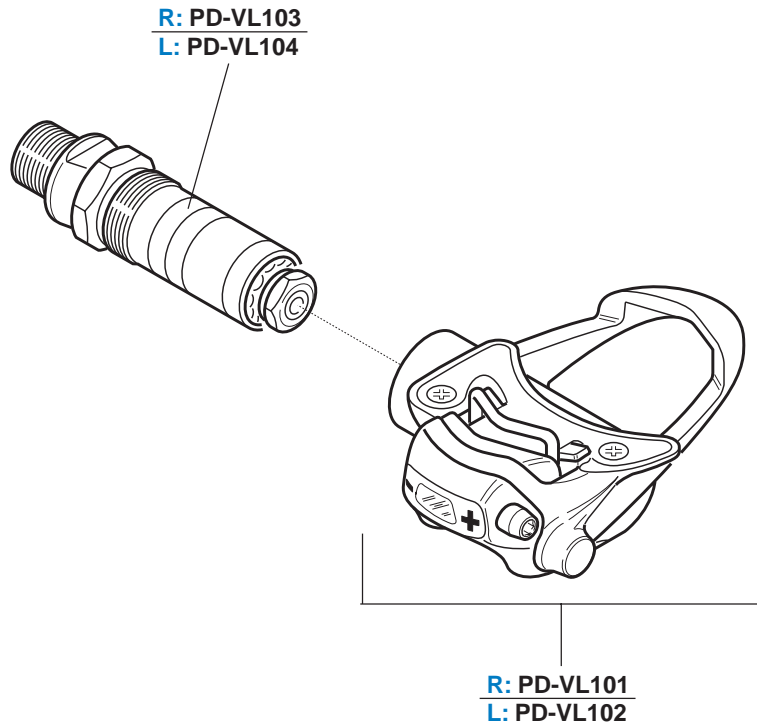

PRO-FIT PEDALS SPARE PARTS

PD-RE106

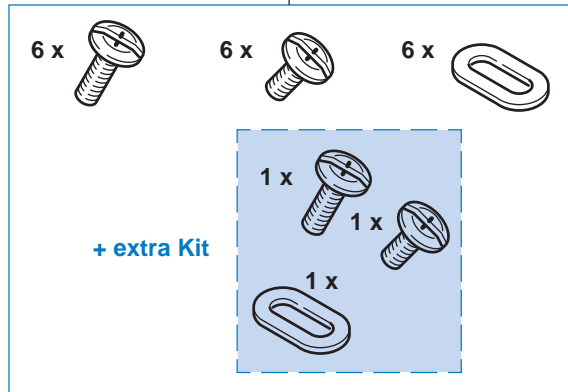

R + L: PD-RE105

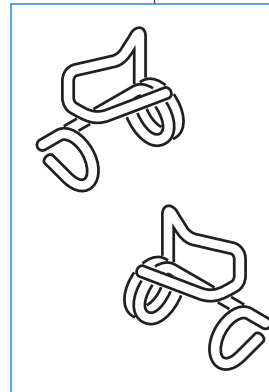

PD-RE107

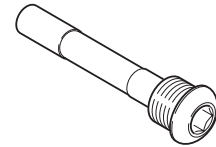

PRO-FIT PEDALS
SPARE PARTS
(blister-packed)

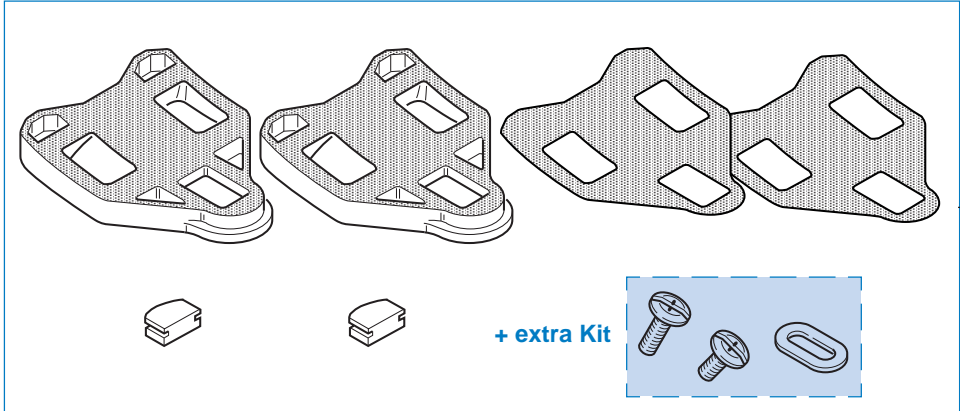



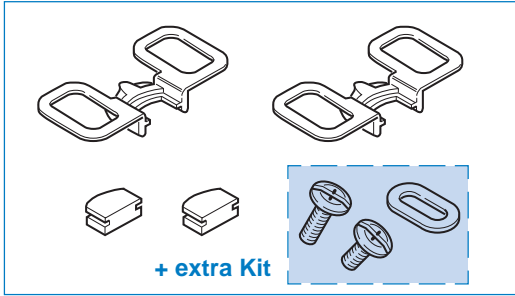



FLOATING CLEATS
PD-RE020



PD-RE100

COMPLETE SETS			
ERGOPOWER	<i>RECORD 9 SPEED</i>		CG-ER201
	<i>CHORUS 9 SPEED</i>		
	<i>ATHENA 9 SPEED</i>		
	<i>VELOCE 9 SPEED</i>		CG-ER102
<i>MIRAGE 9 SPEED</i>			
<i>AVANTI</i>			
TRADITIONAL	<i>RECORD 9 SP.</i>	brakes	CG-BR201
		derailleurs	CG-DD101

SPARE PARTS		FRONT		REAR		
BRAKES		Ø 1,6 mm L. 800 mm CG-CB003		Ø 1,6 mm L. 1600 mm CG-CB013		
		Ø 5 mm L. 580 mm CG-CS014		Ø 5 mm L. 1250 mm CG-CS002		
		Ø 6 mm CG-CS111 (not sealed/senza guarnizione)				
DERAILLEURS	 Ø 1,2 mm	ERGOPOWER	L. 1600	CG-CB014		
		ERGOPOWER	L. 2000	CG-CB009		
		SHIFTING LEVERS	L. 830	CG-CB011		
		SHIFTING LEVERS	L. 1600	CG-CB014		
	 Ø 4,5 mm	ERGOPOWER	L. 680	CG-CS015		
		ERGOPOWER	L. 330	CG-CS008		
		Ø 5,7 mm CG-CS012 (sealed/con guarnizione) <u>for RE/CH/AT</u>				
		Ø 5,7 mm CG-CS016 <u>for VL/MI/AV</u>				
	Ø 5,7/4 mm CG-CS013 (sealed/con guarnizione) <u>for RE/CH/AT</u>					
	Ø 5,7/4 mm CG-CS017 <u>for VL/MI/AV</u>					

CABLE GUIDE PLATES

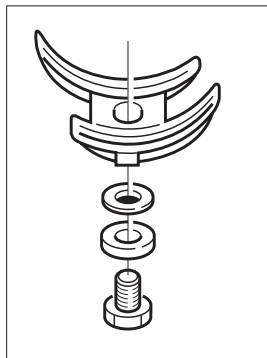

AI-00CD (stainless steel)

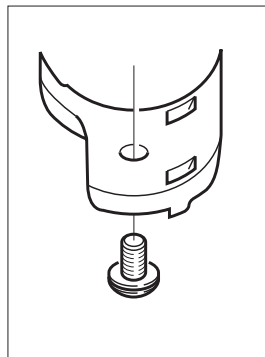

AI-12CD (resin)

ERGOPOWER BLOCKS

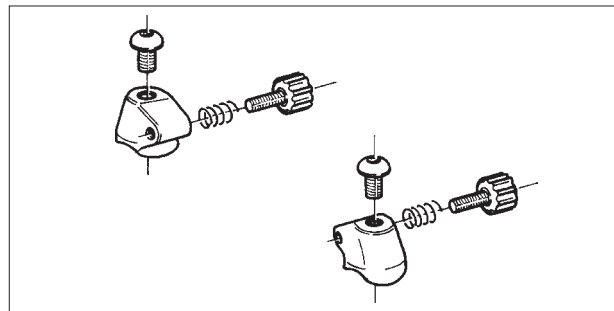

FOR STEEL FRAME

Aluminium: **EC-RE001** Resin: **EC-AT001**

8 SPEED ADAPTER KIT FOR 9 SPEED HUBS AND WHEELS

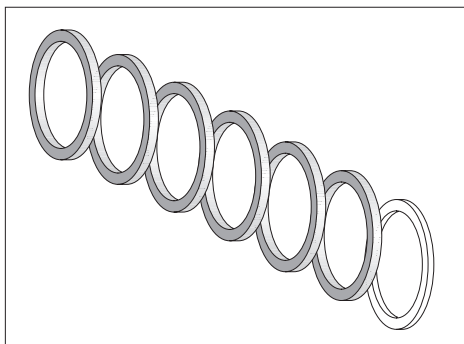

KIT-03

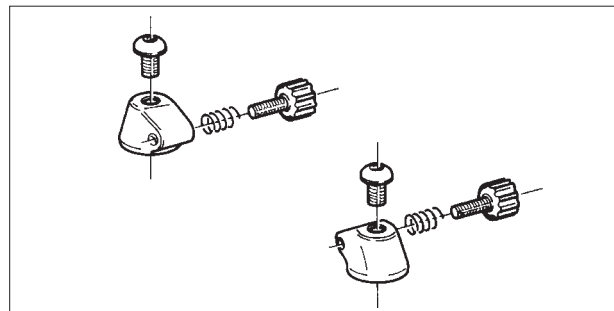

FOR CARBON FRAME

Aluminium: **EC-RE002** Resin: **EC-AT002**

BORA 9 SPEED

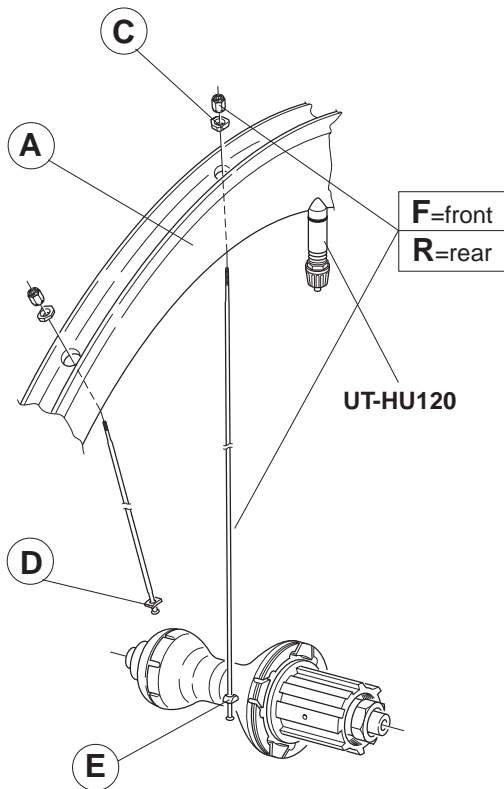

	COMPLETE WHEELS	A	compl. KIT (F + C + D)	compl. KIT (R + C + D + E)	MINI-KIT
FRONT	R-BO102 tubular 28"	WH-201BO	KIT-11BO (16F+16C+16D)		KIT-100BO (2 F + 2 R right + 2 R left + 6 C + 4 D + 2 E)
REAR	R-BO202 tubular 28"	WH-301BO		KIT-12BO (9 R right + 9 R left + 18 C + 9 D + 9 E)	

	COMPLETE WHEELS	F	R right	R left
FRONT	R-BO102 tubular 28"	L. 278 mm		
REAR	R-BO202 tubular 28"		L. 277 mm	L. 278 mm

BORA

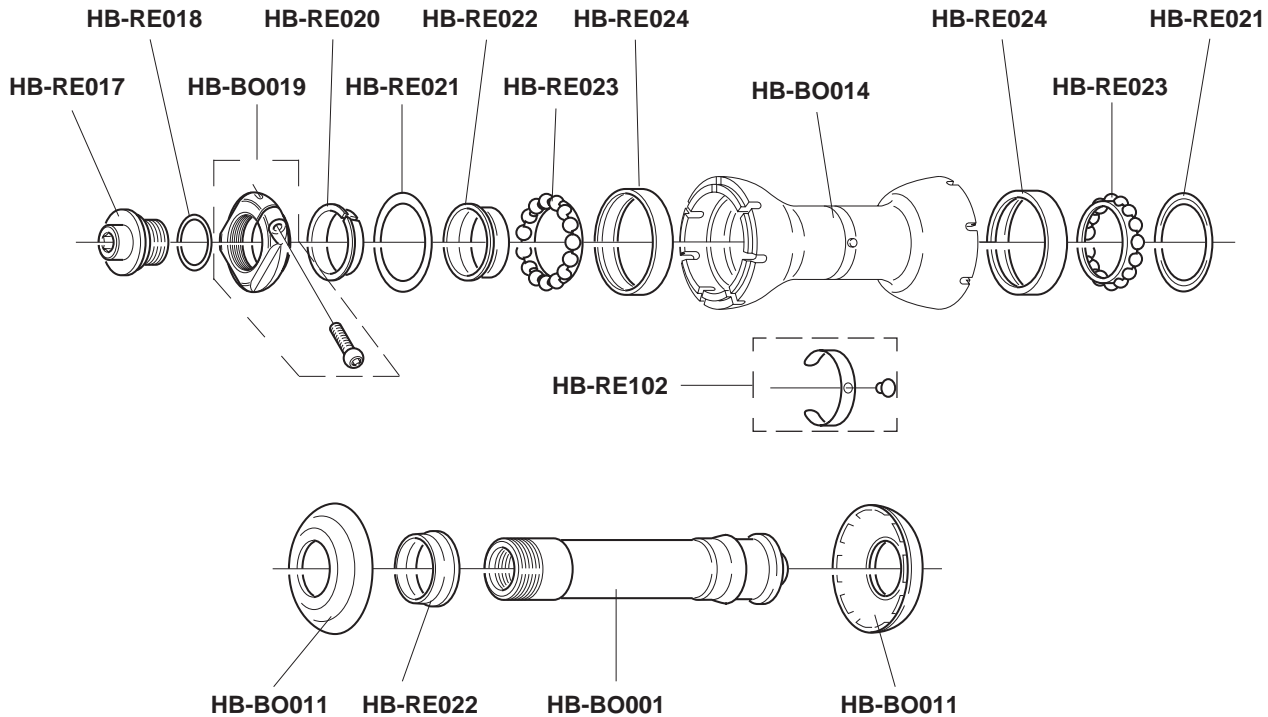

**BORA
9 SPEED**

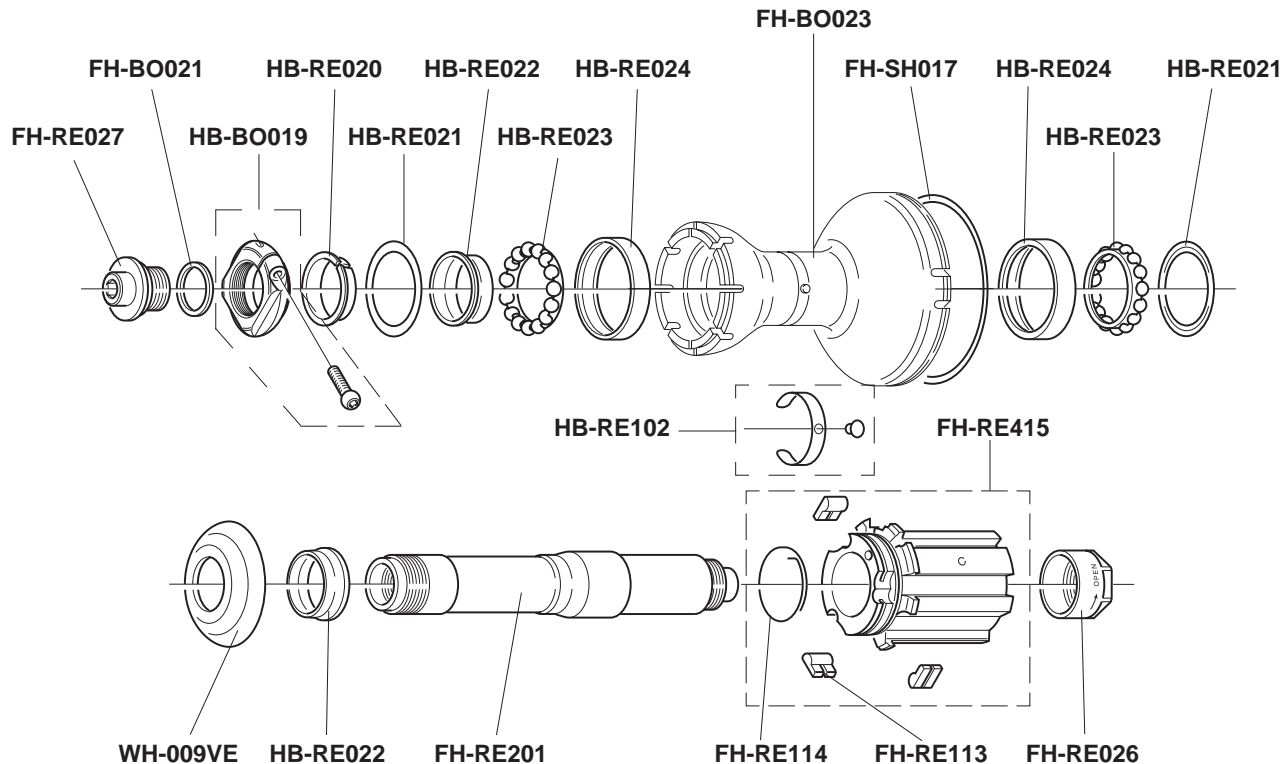

SHAMAL 9 SPEED

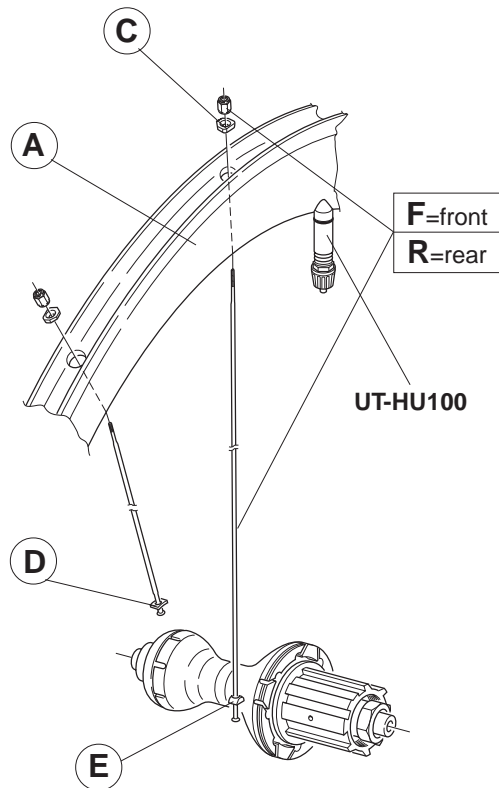

	COMPLETE WHEELS	A	compl. KIT (F + C + D)	compl. KIT (R + C + D + E)	MINI-KIT
FRONT	R-SH111 tubular 28"	WH-201SM	KIT-11SM (16 F+16 C+16D)		KIT-100SM (2 F + 2 R right + 2 R left + 6 C + 4 D + 2 E)
	R-SH306 clincher 28"	WH-401SM			
REAR	R-SH213 tubular 28"	WH-301SM	KIT-12SM (9 R right + 9 R left + 18 C + 9 D + 9 E)		
	R-SH407 clincher 28"	WH-501SM			

	COMPLETE WHEELS	F	R right	R left
FRONT	R-SH111 tubular 28"	L. 283 mm		
	R-SH306 clincher 28"	L. 283 mm		
REAR	R-SH213 tubular 28"		L. 283 mm	L. 283 mm
	R-SH407 clincher 28"		L. 283 mm	L. 283 mm

SHAMAL

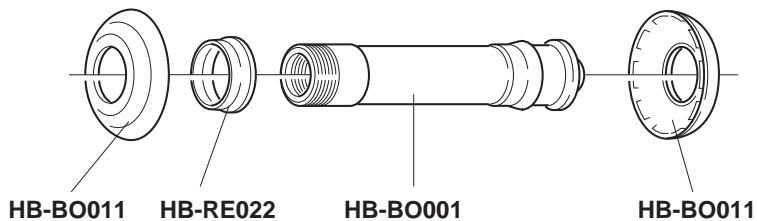
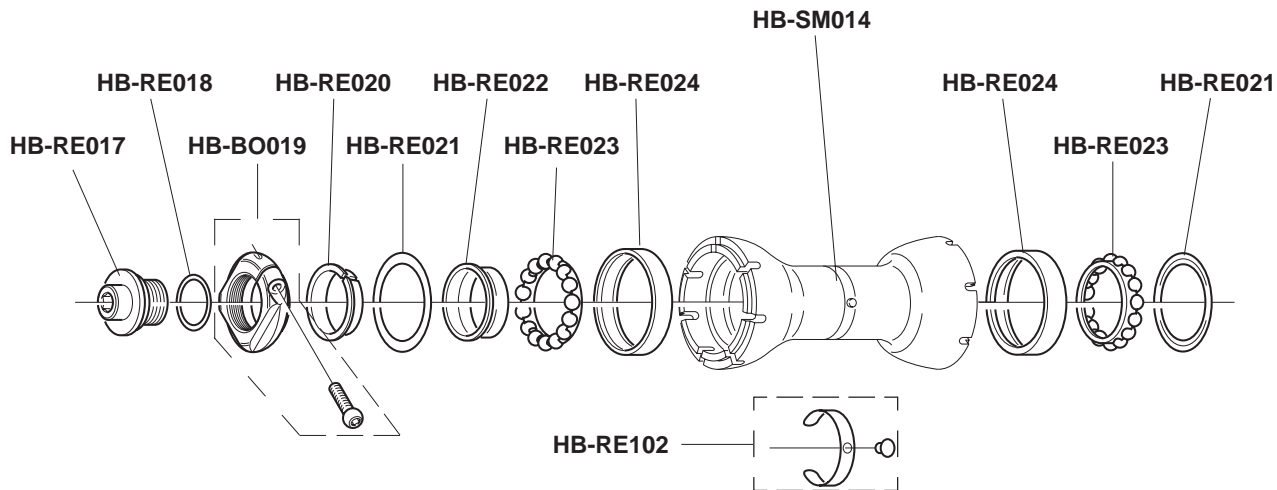

SHAMAL 9 SPEED

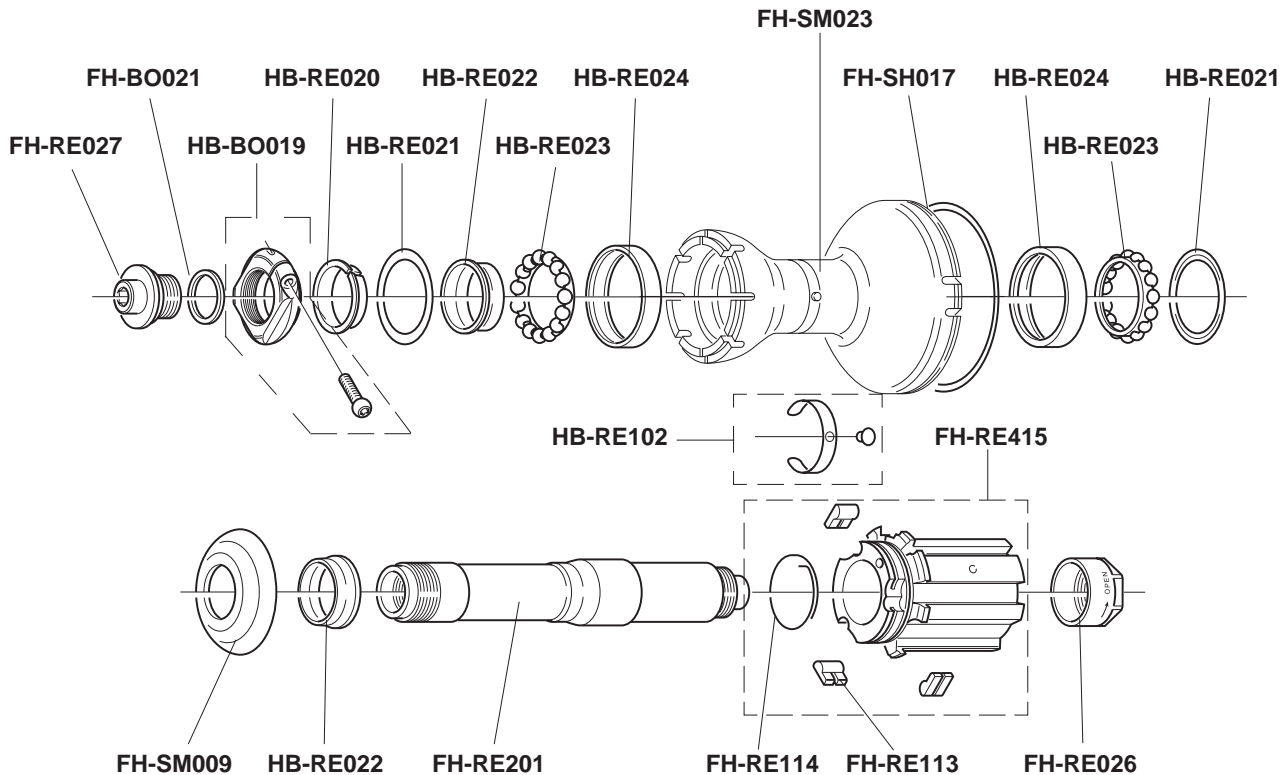

SHAMAL PISTA

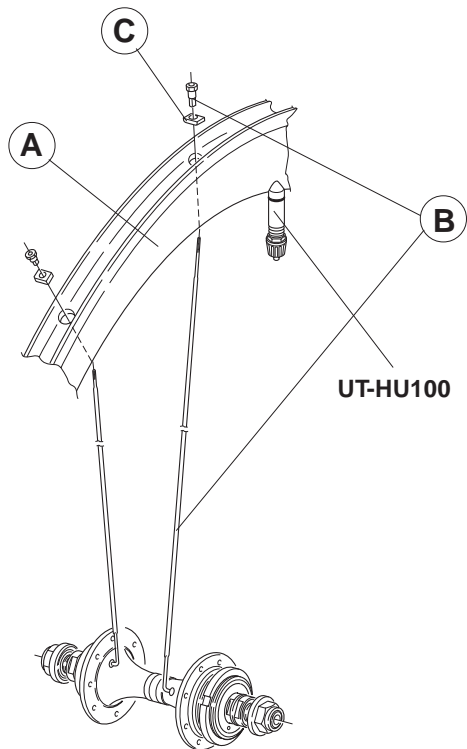

	COMPLETE WHEEL	A	KIT (B + C)
FRONT	R-SH107 tubular 28"	WH-026SH	KIT-01SH
REAR	R-SH204 tubular 28"	WH-026SH	KIT-02SH

	COMPLETE WHEEL	B	B right	B left
FRONT	R-SH107 tubular 28"	L. 276 mm		
REAR	R-SH204 tubular 28"		L. 277 mm	L. 274 mm

SHAMAL PISTA

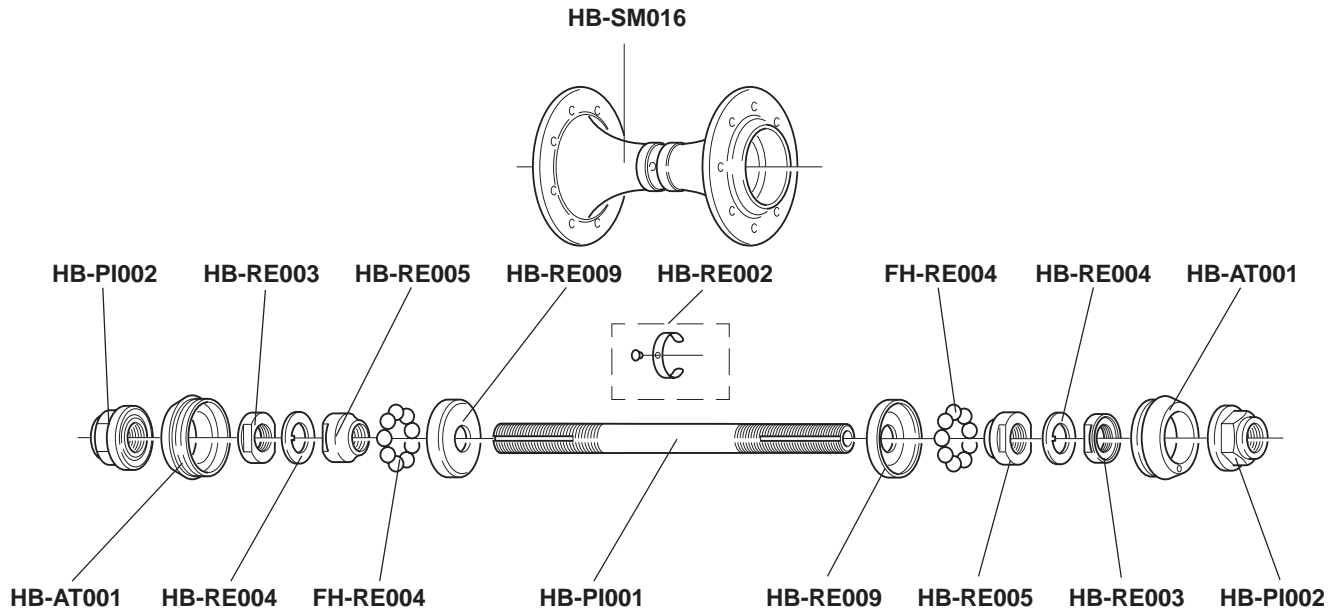

**SHAMAL
PISTA**

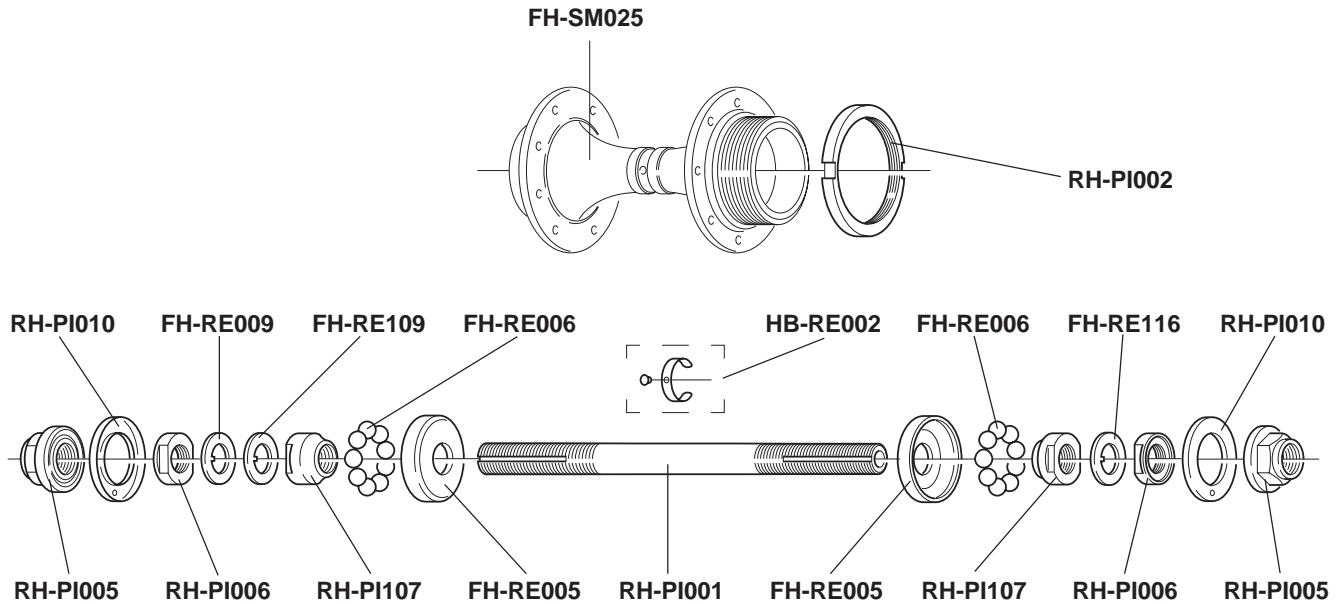

VENTO 9 SPEED

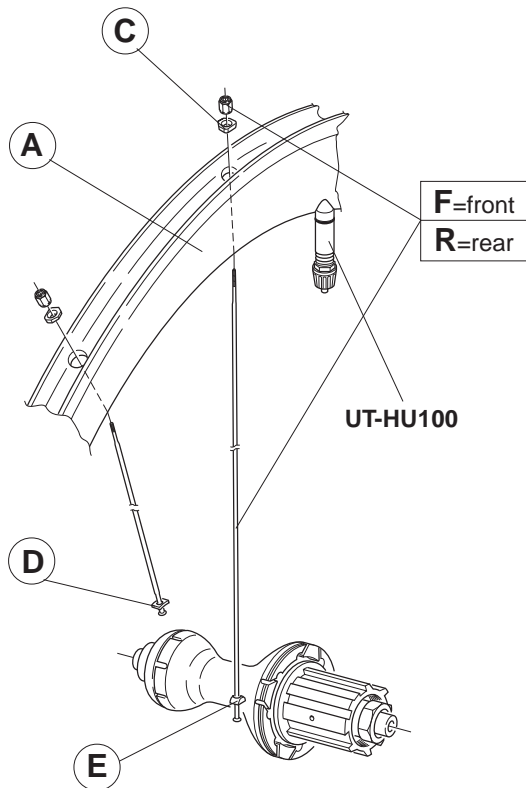

	COMPLETE WHEELS	A	compl. KIT (F + C + D)	compl. KIT (R + C + D + E)	MINI-KIT
FRONT	R-VE312 clincher 28"	WH-102VE	KIT-01VE (16 F + 16 C + 16 D)		KIT-100VE (2 F + 2 R right + 2 R left + 6 C + 4 D + 2 E)
REAR	R-VE412 clincher 28"	WH-104VE		KIT-02VE (9 R right + 9 R left + 18 C + 9 D + 9 E)	

	COMPLETE WHEELS	F	R right	R left
FRONT	R-VE312 clincher 28"	L. 283 mm		
REAR	R-VE412 clincher 28"		L. 283 mm	L. 283 mm

VENTO

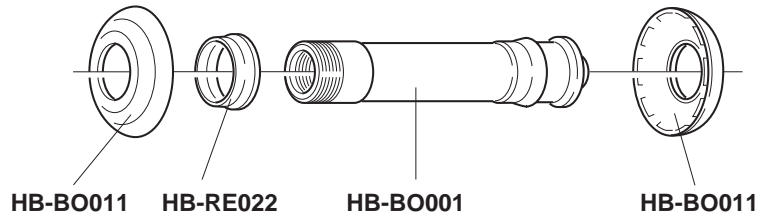
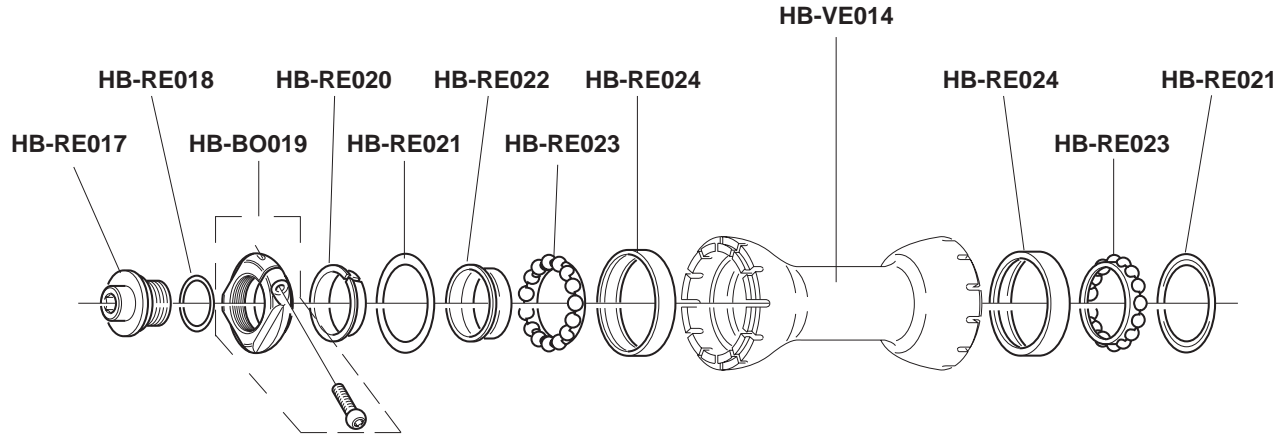

VENTO 9 SPEED

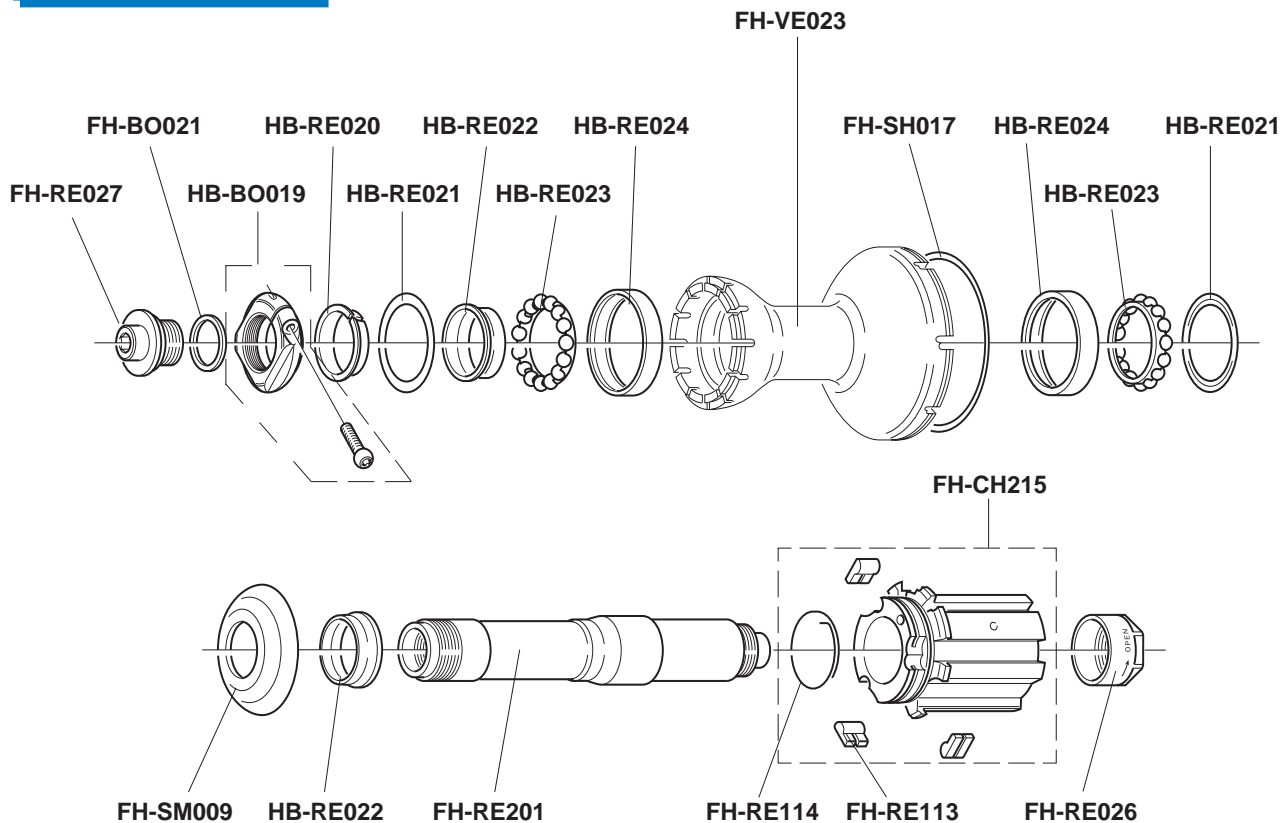

NUCLEON 9 SPEED

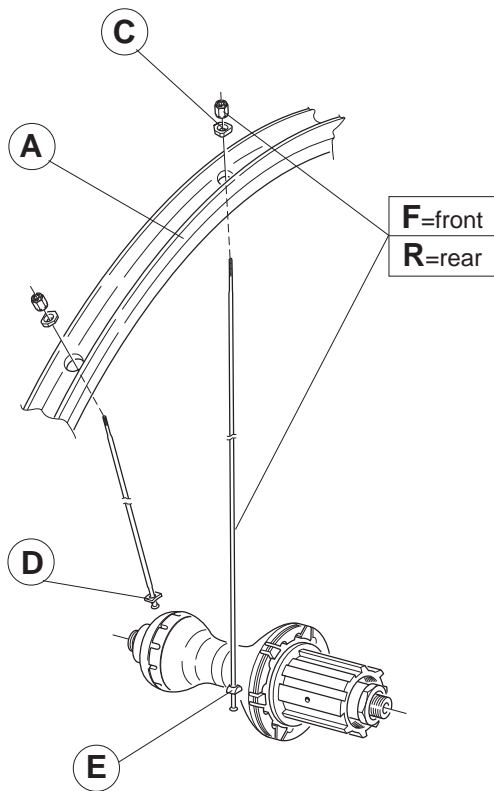

	COMPLETE WHEELS	A	compl. KIT (F + C + D)	compl. KIT (R + C + D + E)	MINI-KIT
FRONT	R-NU100 tubular 28"	WH-201NU	KIT-01NU (24 F+24 C+24D)		tubular KIT-100NU (2 F + 2 R right + 2 R left + 6 C + 4 D + 2 E)
	R-NU300 clincher 28"	WH-401NU	KIT-03NU (24 F+24 C+24D)		
REAR	R-NU200 tubular 28"	WH-301NU		KIT-02NU (12 R right + 12 R left + 24 C + 12 D + 12 E)	clincher KIT-200NU (2 F + 2 R right + 2 R left + 6 C + 4 D + 2 E)
	R-NU400 clincher 28"	WH-501NU		KIT-04NU (12 R right + 12 R left + 24 C + 12 D + 12 E)	

	COMPLETE WHEELS	F	R right	R left
FRONT	R-NU100 tubular 28"	L. 298 mm		
	R-NU300 clincher 28"	L. 294,5 mm		
REAR	R-NU200 tubular 28"		L. 301 mm	L. 298 mm
	R-NU400 clincher 28"		L. 296,5 mm	L. 294,5 mm

NUCLEON

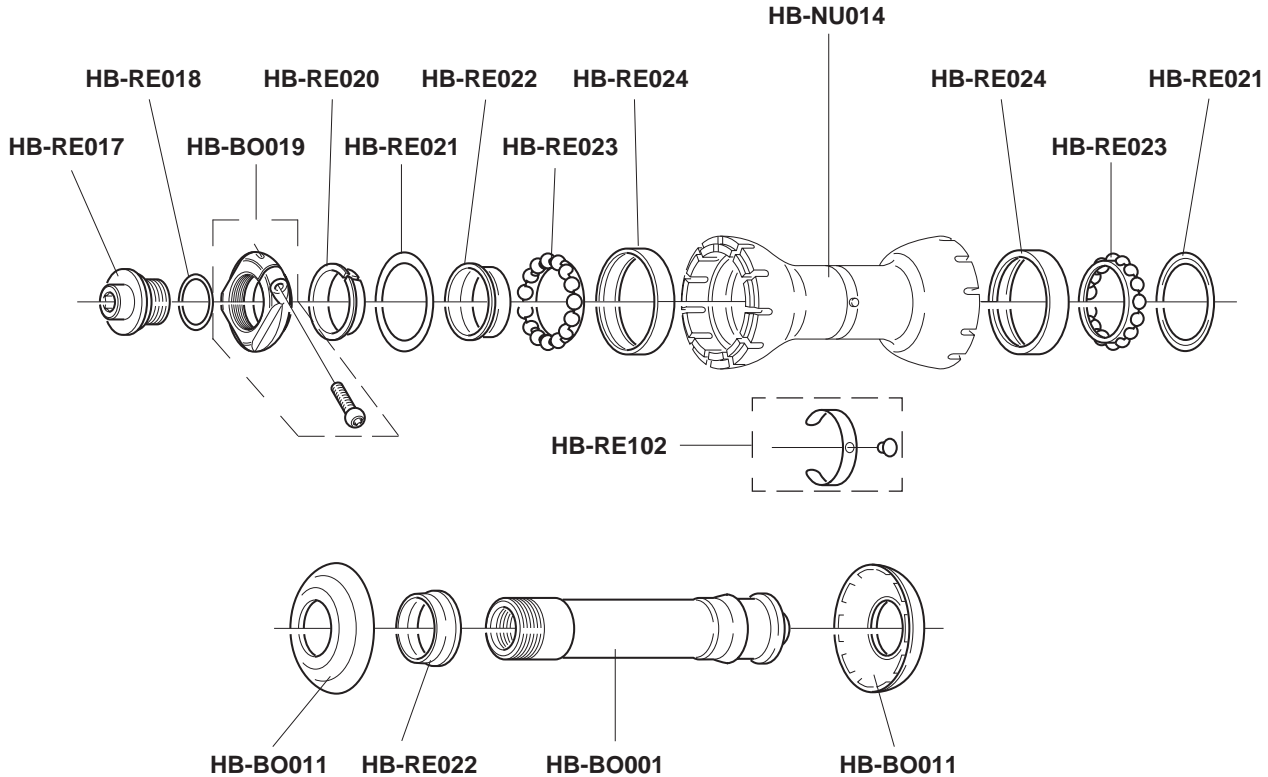

NUCLEON 9 SPEED

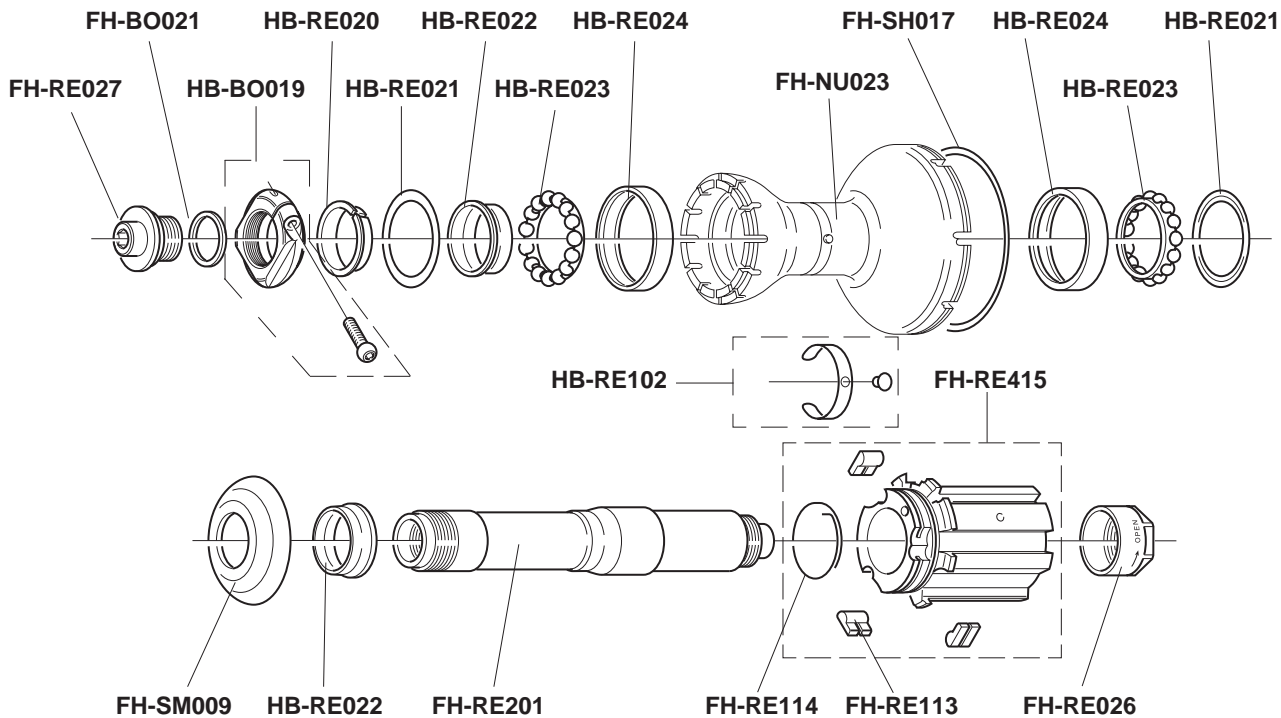

ELECTRON 9 SPEED

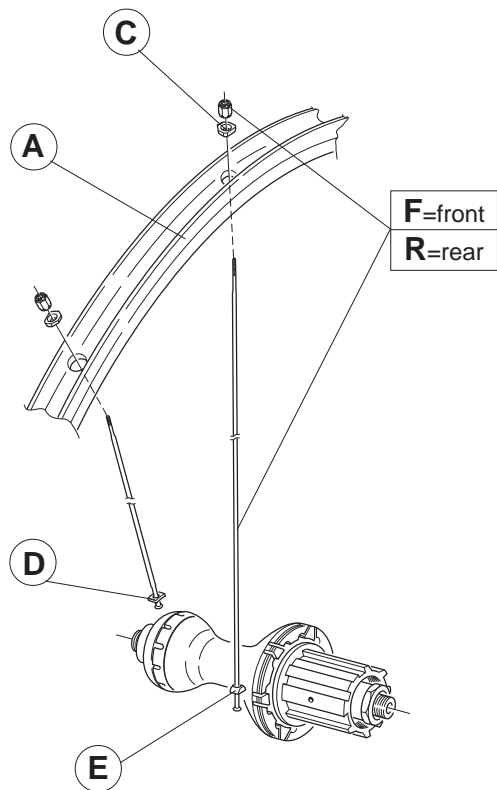

	COMPLETE WHEELS	A	compl. KIT (F + C + D)	compl. KIT (R + C + D + E)	MINI-KIT
FRONT	R-EL302 clincher 28"	WH-102EL	KIT-01EL (24 F+24 C+24 D)		KIT-100EL (2 F + 2 R right + 2 R left + 6 C + 4 D + 2 E)
REAR	R-EL402 clincher 28"	WH-103EL		KIT-02EL (13 R right + 13 R left + 26 C + 13 D + 13 E)	

	COMPLETE WHEELS	F	R right	R left
FRONT	R-EL302 clincher 28"	L. 295 mm		
REAR	R-EL402 clincher 28"		L. 296,5 mm	L. 295 mm

ELECTRON

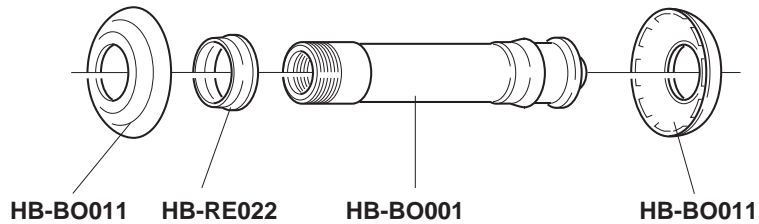
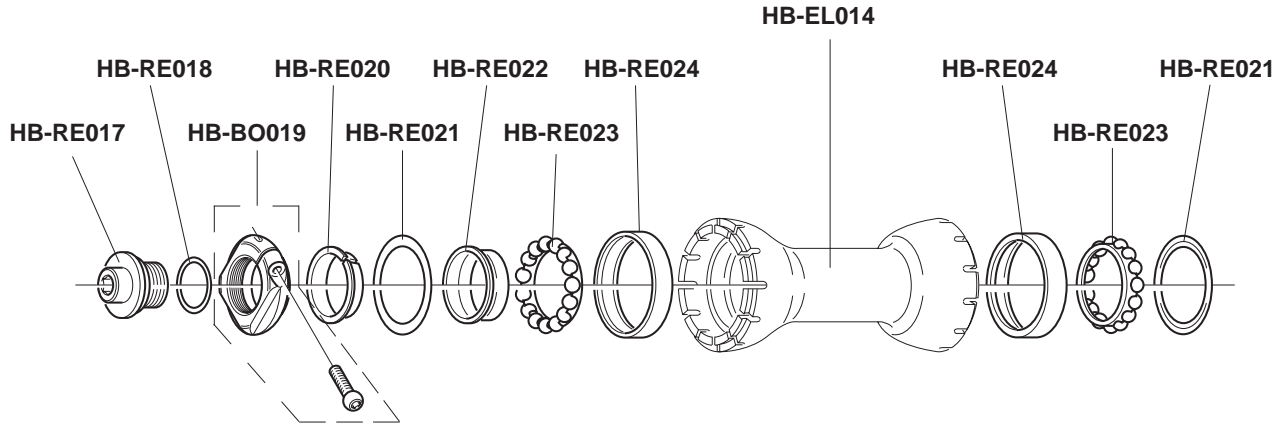

ELECTRON 9 SPEED

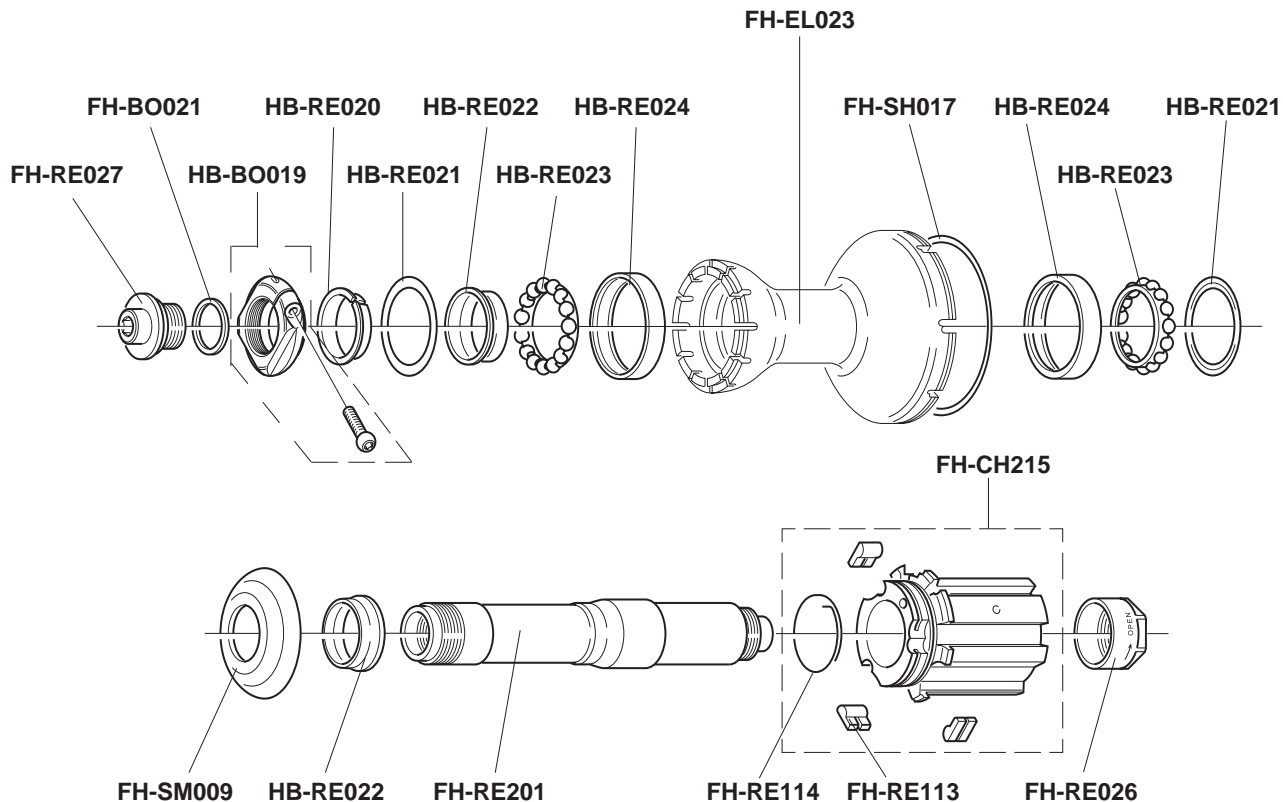

PROTON 9 SPEED

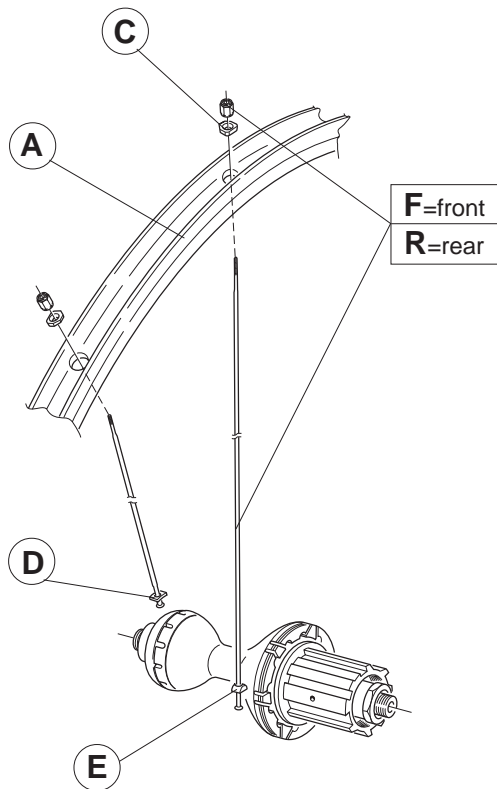

	COMPLETE WHEELS	A	compl. KIT (F + C + D)	compl. KIT (R + C + D + E)	MINI-KIT
FRONT	R-PR302 clincher 28"	WH-101PR	KIT-01PR (24 F+24 C+24 D)		KIT-100PR (2 F + 2 R right + 2 R left + 6 C + 4 D + 2 E)
REAR	R-PR402 clincher 28"	WH-102PR		KIT-02PR (13 R right + 13 R left + 26 C + 13 D + 13 E)	

	COMPLETE WHEELS	F	R right	R left
FRONT	R-PR302 clincher 28"	L. 295 mm		
REAR	R-PR402 clincher 28"		L. 296,5 mm	L. 295 mm

PROTON

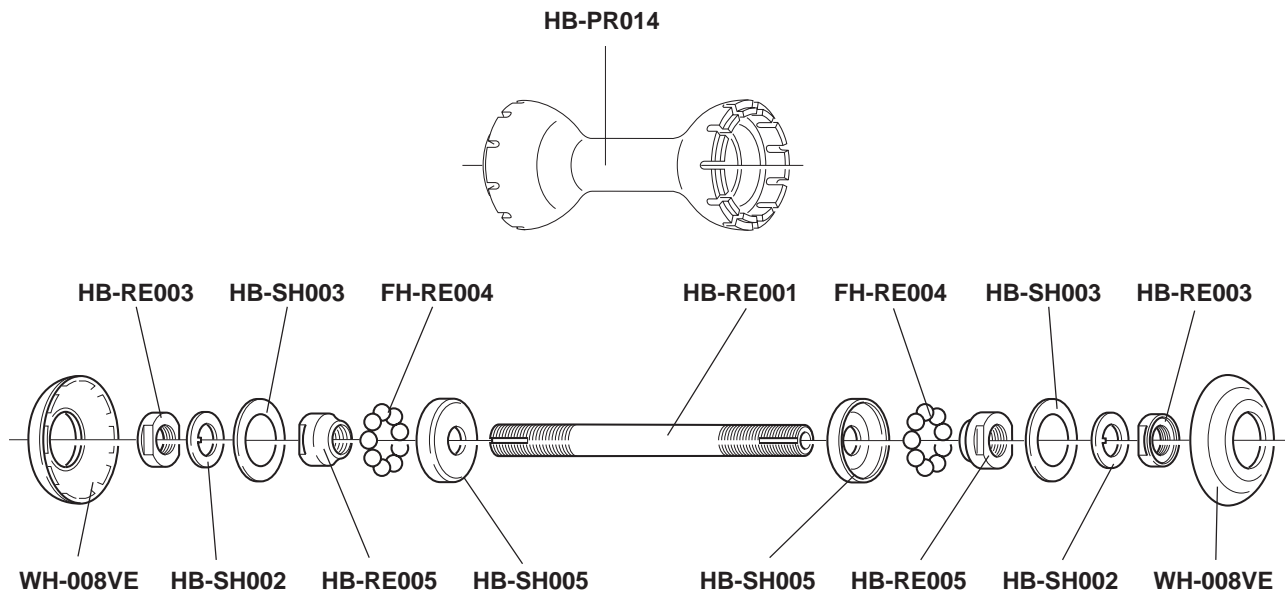

**PROTON
9 SPEED**

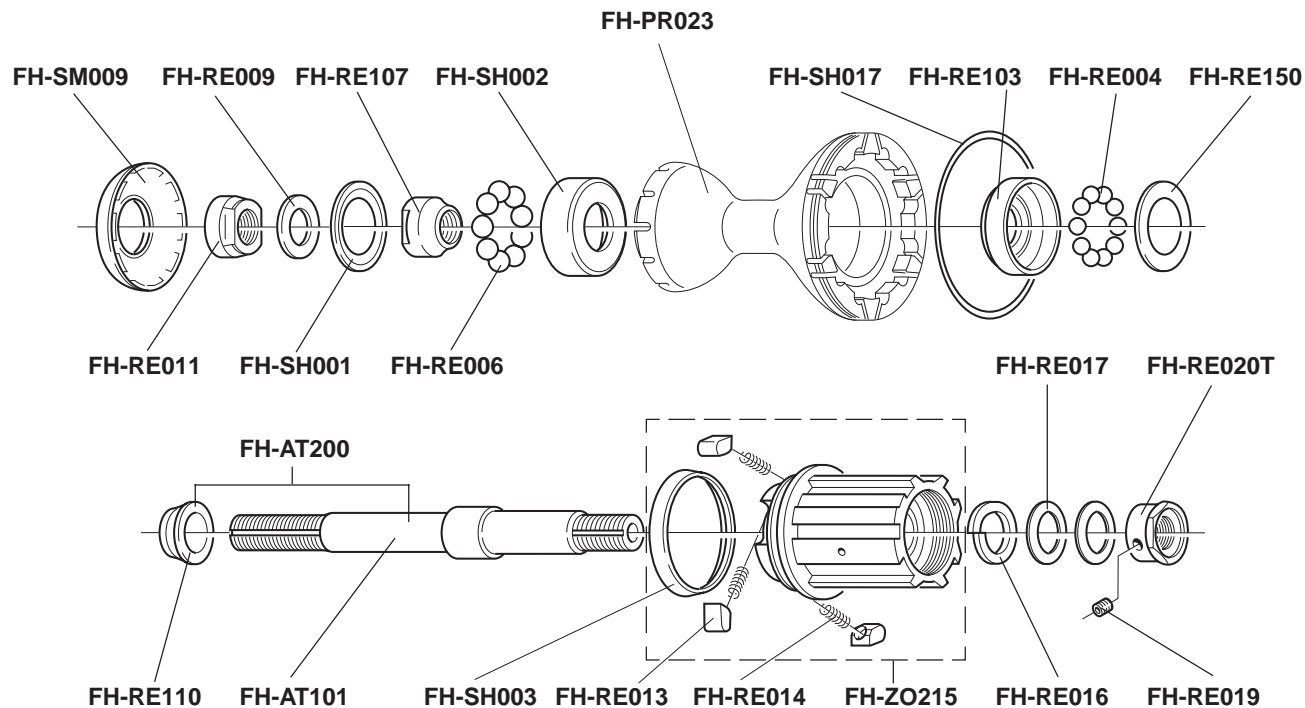

	ENGLISH	ITALIANO	FRANÇAIS	DEUTSCH
R	RIGHT	DESTRO	DROIT	RECHTS
L	LEFT	SINISTRO	GAUCHE	LINKS
F	FRONT	ANTERIORE	AVANT	VORDERRAD
R	REAR	POSTERIORE	ARRIERE	HINTERRAD
IT	ITALIAN	ITALIANO	ITALIEN	ITALIENISCH
BC	ENGLISH	INGLESE	ANGLAIS	ENGLISCH
TUBULAR	TUBULAR	TUBOLARE	BOYAU	SCHLAUCHREIF
CLINCHER	CLINCHER	COPERTONCINO	PNEU ETROIT	DRAHTREIF

**ITALY****CAMPAGNOLO SRL***

Via della Chimica, 4 - 36100
Vicenza

Ph. +39-0-444-225604

Fax: +39-0-444-225400

E-Mail: service@campagnolo.com

FRANCE**CAMPAGNOLO FRANCE ***

B.P. 148 - 42160 Andrezieux - Boutheon Cedex

Ph: +33-477-556305

Fax: +33-477-556345

E-Mail: campagnolo@campagnolo.fr

MINIC 2000*

Z.A. du Champ Niguel B.P. 52 - 35170 Bruz

Ph: +33-2-99050656

Fax: +33-2-99529859

SOCIETE ALVAREZ JOSE*

Route d'Agen - Z.I. Nord - 32020 Auch-Cedex 09

Ph: + 33-562-601158

Fax: +33-562-601173

E-Mail: pb.alvarez@wanadoo.fr

CYCLES LAPIERRE S.A.*

Rue Edmond Voisenet - 21005 Dijon Cedex

Ph: +33-3-80525186

Fax: +33-3-80520851

E-Mail: gilles.lapierre@wanadoo.fr

SPAIN**CAMPAGNOLO IBERICA***

Pintor Jesus Apellaniz, 17 - 01008 Vitoria

Ph: + 34-945-222504

Fax: +34-945-244007

E-Mail: campagnolo@campagnolo.es

COMET*

Polig. Erratzu, S/N - Alto de Irurain

Apartado Postal 191 - 20130 Urnieta Gipiuzkoa

Ph: +34-943-330195

Fax: +34-943-552556

E-Mail: cometsa@nexo.es

JAIME LLORENTE *

Capitan Blanco Argibay, 141
28029 Madrid

Ph: +34-91-3153496

Fax: +34-91-3230652

E-Mail: a069314@sp-editores.es

ENGLAND**J.D. WHISKER LTD***

Bridgegate C.Tre - Martinfield AL71JG

Welwyn Garden City

Ph: +44-143-8798772

Fax: +44-143-879548

MERCIAN CYCLES

7, Shardlow Road, Alvaston - Derby DE2 0JG

Ph: +44-1332-752468

Fax: +44-1332-751033

GERMANY**CAMPAGNOLO DEUTSCHLAND GMBH***

An der Schusterinsel, 15 - 51379 Leverkusen

Ph: +49-2171-72430

Fax: +49-2171-724315

E-Mail: campagnolo@campagnolo.de

STIER*

Johannesstr. 11 - 70176 Stuttgart 1

Ph: +49-711-618801

Fax: +49-711-628577

BRÜGELMANN

Oberrliederbacherweg, 42

65842 Sulzbach/Frankfurth

Ph: +49-6196-750075

Fax: +49-6196-750074

E-Mail: info@bruegelmann.de

AUSTRIA**WEKU***

Rebgarten, 6 - 6973 Höchst

Ph: +43-5578-74911

Fax: +43-5578-74912

E-Mail: weku@weku.at

FINLAND**VELOSPORT**

Kimmontie, 5 - 00610 Helsinki P.

Ph: +358-975-71377

Fax: +358-979-5498

E-Mail: info@velosport.fi

SWEDEN**VISOM CYKLAR AB***

Sjoviksvagen, 2 - 23162 Trelleborg

Ph: +46-410-41273

Fax: +46-410-41273

E-Mail: visom@trelleborg.mail.telia.com

RACERDEPAN

Drottninggatan, 1 - 44735 Vargarda

Ph: +46-32220590

Fax: +46-32224206

DENMARK**AAGE KROLL***

Jydekrogen, 18 - Vallensbaek 2625

Ph: +45-43-660066

Fax: +45-43-660099

HOLLAND**WOUT VERHOEVEN***

Rodenrijsweg 409 - 2651Am Berkel en Rodenrijs

Ph: +31-10-5115014

Fax: +31-10-5117708

CARD BENELUX*

Nispensestraat, 72 - 4701 Cx Roosendaal

Ph: +31-165-564241

Fax: +31-165-563248

BELGIUM

SIMONS BV *

Staatsbaan, 279 - Bekkevoort 3260
Ph: +32-166-32095
Fax: +32-166-32840

BIKETEC N.V.*

Getweg, 78 - 9890 Gavere
Ph: +32-9-3845111
Fax: +32-9-3844914

SWITZERLAND

PIERO ZURINO AG*

Frauenfelderstrasse, 20 - 9542 Münchwilen TG
Ph: +41-71-9666722
Fax: +41-71-9666690
E-Mail: pierozurino@bluewin.ch

U.S.A.

CAMPAGNOLO USA INC.*

2105-L Camino Vida Roble - Carlsbad CA 92008
Ph. +1-760-9310106
Fax: +1-760-9310991
E-Mail: info@campagnolousa.com

OCHSNER INT. INC.*

246 Marquardt Drive - Wheeling, IL 60090
Ph: +1-847-4658200
Fax: +1-847-4658282
E-Mail: ochsner@sprynet.com

EUROASIA*

3935 Foothill Blvd, STE A - 91214 La Crescenta, CA
Ph: +1-818-2481814
Fax: +1-818-2481243

QUALITY BIC. PRODUCTS*

6400 w. 105TH Street - Bloomington,
MN 55438-2554
Ph: +1-612-9419391
Fax: +1-612-9419799
E-Mail: campagnoloservice@qbp.com

UNITED BICYCLE PARTS*

691 Washington Street - 97520 Ashland, OR
Ph: +1-541-4881984
Fax: +1-541-4880192

CANADA

CYCLES MARINONI

1067, Levis Lachenaie - Quebec J6W 4L2
Ph: +1-450-4717133
Fax: +1-450-4719887
E-Mail: webmaster@marinoni.qc.ca

GREAT WESTERN

233 West Broadway - Vancouver, BC V5Y 1P5
Ph: +1-604-8722424
Fax: +1-604-8720222

LATIN AMERICA

PACIFIC BIKE CO.*

Rua Alvarenga 1511 - City Butantia -
CEP 05509-00 Sao Paulo/SP - BRASIL
Ph.+55-11-8162249
Fax:+55-11-8160544

CASA ITALIA

Av. Agraciada 4174 - Montevideo - URUGUAY
Ph: +598-2-3098142
Fax: +598-2-3045539
E-Mail: casaital@adinet.com.uy

ANGEL DIAZ*

Av. Constituyentes 4884 - Casilla de Correo 149
1431 Buenos Aires - ARGENTINA
Ph: +54-157-16481
Fax: +54-157-27048
E-Mail: info@rodadosdiaz.com.ar

NEW ZEALAND

WH WORRALL*

Symonds Street - P.O. Box 8381 - Auckland
Ph: +64-9-6303901
Fax: +64-9-6303839
E-Mail:office@worrall.co.nz

AUSTRALIA

CONTINENTAL OC. P/L*

P.O. Box 42 - Bondi Junction - 2022 NSW
Ph: +61-2-93694761
Fax: +61-2-93892662
E-Mail: contipecc@ozemail.com.au

BIKE SPORTZ*

11 Macbeth Street - Braeside, Victoria 3195
Ph: +61-3-95872344
Fax: +61-3-95876951
E-Mail: cramerd@ozemail.com.au

FAR EAST

THE WING'S CO.

250 Tung Shoi St. G/F Mongkok - Kowloon
HONG KONG
Ph: +852-2381-2635
Fax: +852-23-974094

KAWASHIMA*

N. 4-2-4, Kushiya-Cho - Higashi Sakai
590 Osaka JAPAN
Ph: +81-722-381557
Fax: +81-722-386213
E-mail: riog@osk.3web.ne.jp

NICHINAO SHOKAI*

6-16-8 Sotokanda Chyodaku - 101 Tokyo
JAPAN
Ph: +81-3-38326251
Fax: +81-3-38326266
E-Mail:daiou@hi-ho.ne.jp



NOTA IMPORTANTE: gli indirizzi contrassegnati con un asterisco (*) si riferiscono a grossisti o a filiali della Campagnolo che **non** vendono direttamente al pubblico. Potete contattarli per sapere quale è il rivenditore di ricambi originali Campagnolo più vicino a voi.

IMPORTANT NOTICE: sources marked with an asterisk (*) indicate wholesale distributors or Campagnolo branch offices and do **not** sell directly to the public. When contacted for spare part purchases they might refer you to the closest retailer in your area.