

SPARE PARTS

SAFETY RECOMMENDATIONS

A - BEFORE EVERY RIDE

- Check to be sure that all quick release fasteners, nuts and bolts are properly adjusted. Bounce the bicycle on the ground and listen and look for anything which may be loose.
- Be sure that your tires are inflated to the correct pressure and that there is no damage whatsoever in the tread or sidewall.
- Be sure that none of the spokes are damaged or loose.
- Be sure that your wheels are perfectly centered. Spin the wheels to be sure that they do not wobble up and down or from side to side, and that they do not make contact with the brake pads while rotating.
- Check your brake pads and cables to be sure they are in good condition.
- Test your brakes in the beginning of your ride to make sure that they are operating properly.
- Check all reflectors to make sure that they are clean, straight, and securely mounted.
- Learn and follow the local bicycle laws and regulations, and obey all traffic signals, signs and laws while you ride.

DO NOT RIDE YOUR BICYCLE IF IT DOES NOT PASS THIS PRE-RIDE TEST. CORRECT ANY CONDITION BEFORE YOU RIDE!

B - GENERAL SAFETY RECOMMENDATIONS

- Be sure that the periodic maintenance schedule is strictly followed.
- Always use original Campagnolo® spare parts.
- Wear clothes which are snug-fitting and which make you visible to traffic, such as neon, fluorescent, or other bright colors.
- Avoid biking at night, because it is more difficult for you to be seen by traffic, and it is more difficult for you to see obstructions on the ground. If you do ride at night, you should equip your bicycle with and use a headlight and a taillight.
- When riding in wet conditions, remember that the stopping power of your brakes is greatly reduced and that the adherence of the tires on the ground is considerably reduced. Also bear in mind that because of the progressive drying of the braking surface during braking itself, braking power may vary sharply. This makes it harder to control and stop your bicycle. Extra care is required when riding your bicycle in wet conditions to avoid an accident.
- Campagnolo S.r.l. reminds you to always wear a properly fitted and fastened bicycle helmet that has been approved by ANSI or SNELL.
- If you ever have any comments, questions, or concerns, please contact your nearest Campagnolo® dealer.

NEUTRON™ ULTRA™ clincher

LOW PROFILE

INTENDED USE	WHEEL CODES	DESCRIPTION	WEIGHT
This product has been designed and manufactured to be fitted and used only on "racing" or "cyclocross" bikes (if they bear the CX mark), and any other use is expressly excluded. Any other use of this product (like, for instance, cross country, all mountain-enduro, acrobatic off-road, downhill, fourcross, freeride, free-style or any other type of extreme off-road cycling as defined by UCI) can cause accidents, injuries and even death and is therefore expressly forbidden.	WH7-NECFRU	FRONT+REAR Campagnolo FW body	1.470
	WH12-NECFRXU	FRONT+REAR HG type FW body	1.509
	WH7-NECFU	front	630
	WH7-NECRU	rear Campagnolo FW body	840
	WH12-NECRXU	rear HG type FW body	879

RIM			
	<p>FRONT RIM REAR RIM RIM-TAPE LABEL KIT VALVE HOLE DIAMETER TYRE SECTION</p>	<p>WH-403NE (with labels) WH-404NE (with labels) 2-WH-RT01 (18 mm - 2 pieces) LAB-NECC07 (for a pair of front+rear wheels) 6,5 mm 700C (622 x 15C) See section table and inflation pressures on page 205</p>	

HUBS			
	<p>HB-BO027 HB-NE019 4-HB-RE021 4-HB-RE023 (steel) 4-HB-RE124 HB-SH006 HB-SH006 4-HB-RE124 4-HB-RE023 (steel)</p> <p>4-HB-RE018 HB-RE020 4-HB-RE022 4-HB-RE021</p> <p>3-HB-BO011 4-HB-RE022 HB-BO101 3-HB-BO011</p>	<p>FH-BO027 HB-NE019 4-HB-RE021 4-HB-RE023 (steel) HB-SH006 FH-SH017 4-HB-RE124 4-HB-RE021</p> <p>FH-BO021 HB-RE020 4-HB-RE022 4-HB-RE124 4-HB-RE023 (steel)</p> <p>3-HB-BO011 4-HB-RE022 FH-BO001 5-FH-RE114 3-FH-BO013 FH-BUU015 FH-BUU015X 5-FH-RE114 3-FH-RE113 FH-RE126</p> <p>(Campy 9/11) (HG 8/10)</p>	<p>HB-RE100 HUB KIT 2 x HB-RE021 2 x HB-RE022 2 x HB-RE124 2 x HB-RE023</p>

QUICK-RELEASES	QR11-20BFR	front + rear
----------------	------------	--------------

SPOKES			
COMPLETE FRONT KIT	KIT-33NE	22 front spokes + 22 nuts + 22 nut supporting plates	
COMPLETE REAR KIT	KIT-34NE	12 rear right spokes + 12 rear left spokes + 24 nuts + 24 nut supporting plates	
MINI-KIT	KIT-500NE	2 front spokes + 2 rear right spokes + 2 rear left spokes + 6 nuts + 6 nut supporting plates	
NUTS	10-WH-010BO	10 pieces	
NUT SUPPORTING PLATES	10-WH-011EU	10 pieces	

NOTES

HYPERON™ ONE clincher

LOW PROFILE

INTENDED USE	WHEEL CODES	DESCRIPTION	WEIGHT
This product has been designed and manufactured to be fitted and used only on "racing" or "cyclocross" bikes (if they bear the CX mark), and any other use is expressly excluded. Any other use of this product (like, for instance, cross country, all mountain-enduro, acrobatic off-road, downhill, fourcross, freeride, free-style or any other type of extreme off-road cycling as defined by UCI) can cause accidents, injuries and even death and is therefore expressly forbidden.	WH10-HYCFR1	FRONT+REAR Campagnolo FW body+brake shoes BR-BO500	1.380
	WH10-HYCFRX1	FRONT+REAR HG type FW body+brake shoes BR-BO500X	1.419
	WH10-HYCF1	front+brake shoes BR-BO500	615
	WH10-HYCFX1	front+brake shoes BR-BO500X	615
	WH10-HYCR1	rear Campagnolo FW body+brake shoes BR-BO500	765
	WH10-HYCRX1	rear HG type FW body+brake shoes BR-BO500X	804

RIM

	<p>FRONT RIM REAR RIM RIM-TAPE LABEL KIT VALVE HOLE DIAMETER TYRE SECTION BRAKE SHOES CLINCHER REMOVAL LEVER</p>	<p>WH-003HY1 (with labels) WH-004HY1 (with labels) 2-WH-RT02 (2 pieces) LAB-HY1C10 (for a pair of front+rear wheels) 6,5 mm 622 X 13C See section table and inflation pressures on page 205 for carbon rims - BR-BO500 (for Campagnolo brakes) - BR-BO500X (for Shimano brakes) WH-109HYC (6 pieces)</p>
--	--------------------------------------------------------------------------------------------------------------------------------------------------	-------------------------------------------------------------------------------------------------------------------------------------------------------------------------------------------------------------------------------------------------------------------------------------------------------------------------------------------

HUBS

	<p>HB-RE100 HUB KIT 2 x HB-RE021 2 x HB-RE022 2 x HB-RE124 2 x HB-RE023</p>
QUICK-RELEASES	QR12-BUUBFR front + rear

SPOKES

COMPLETE FRONT KIT	KIT-03HY1	22 front spokes + 22 nuts + 22 front nut supporting plates
COMPLETE REAR KIT	KIT-04HY1	12 rear right spokes + 12 rear left spokes + 24 nuts + 24 rear nut supporting plates
MINI-KIT	KIT-100HY1	2 front spokes + 2 rear right spokes + 2 rear left spokes + 6 nuts + 2 front nut supporting plates + 4 rear nut supporting plates
NUTS	10-WH-010BO	10 pieces
FRONT NUT SUPPORTING PLATES	10-WH-011HY	10 pieces
REAR NUT SUPPORTING PLATES	10-WH-012HY	10 pieces

NOTES

HYPERON™ ULTRA™ TWO clincher

LOW PROFILE

INTENDED USE	WHEEL CODES	DESCRIPTION	WEIGHT
This product has been designed and manufactured to be fitted and used only on "racing" or "cyclocross" bikes (if they bear the CX mark), and any other use is expressly excluded. Any other use of this product (like, for instance, cross country, all mountain-enduro, acrobatic off-road, downhill, fourcross, freeride, free-style or any other type of extreme off-road cycling as defined by UCI) can cause accidents, injuries and even death and is therefore expressly forbidden	WH9-HYCFR	FRONT+REAR Campagnolo FW body+brake shoes BR-BO500	1.345
	WH9-HYCFRX	FRONT+REAR HG type FW body+brake shoes BR-BO500X	1.384
	WH9-HYCF	front+brake shoes BR-BO500	580
	WH9-HYCFX	front+brake shoes BR-BO500X	580
	WH9-HYCR	rear Campagnolo FW body+brake shoes BR-BO500	765
	WH9-HYCRX	rear HG type FW body+brake shoes BR-BO500X	804

RIM	
	<p>FRONT RIM REAR RIM RIM-TAPE LABEL KIT VALVE HOLE DIAMETER TYRE SECTION BRAKE SHOES CLINCHER REMOVAL LEVER</p> <p>WH-203HYU (with labels) WH-104HYU (with labels) 2-WH-RT02 (16 mm - 2 pieces) LAB-HYUC09 (for a pair of front+rear wheels) 6,5 mm 622 X 13C See section table and inflation pressures on page 205 for carbon rims - BR-BO500 (for Campagnolo brakes) - BR-BO500X (per Shimano brakes) WH-109HYC (6 pieces)</p>

HUBS		
	<p>FRONT HUB</p>	
	<p>REAR HUB</p>	<p>HB-HY100 CULT™ KIT 2 x HB-RE021 2 x HB-HY022 2 x HB-HY024 2 x HB-HY123</p>
<p>QUICK-RELEASES</p>	<p>QR12-BUUBFR</p>	<p>front + rear</p>

SPOKES		
<p>COMPLETE FRONT KIT COMPLETE REAR KIT MINI-KIT</p>	<p>KIT-13HYU KIT-14HYU KIT-400HYU</p>	<p>22 front spokes + 22 nuts + 22 front nut supporting plates 12 rear right spokes + 12 rear left spokes + 24 nuts + 24 rear nut supporting plates 2 front spokes + 2 rear right spokes + 2 rear left spokes + 6 nuts + 2 front nut supporting plates + 4 front nut supporting plates</p>
<p>NUTS FRONT NUT SUPPORTING PLATES REAR NUT SUPPORTING PLATES</p>	<p>10-WH-010BO 10-WH-011HY 10-WH-012HY</p>	<p>10 pieces 10 pieces 10 pieces</p>

NOTES		
<p> </p>		

HYPERON™ ULTRA™ TWO tubular

LOW PROFILE

INTENDED USE	WHEEL CODES	DESCRIPTION	WEIGHT
This product has been designed and manufactured to be fitted and used only on "racing" or "cyclocross" bikes (if they bear the CX mark), and any other use is expressly excluded. Any other use of this product (like, for instance, cross country, all mountain-enduro, acrobatic off-road, downhill, fourcross, freeride, free-style or any other type of extreme off-road cycling as defined by UCI) can cause accidents, injuries and even death and is therefore expressly forbidden	WH9-HYTFR	FRONT+REAR Campagnolo FW body+brake shoes BR-BO500	1.231
	WH9-HYRFRX	FRONT+REAR HG type FW body+brake shoes BR-BO500X	1.270
	WH9-HYTF	front+brake shoes BR-BO500	536
	WH9-HYTFX	front+brake shoes BR-BO500X	536
	WH9-HYTR	rear Campagnolo FW body+brake shoes BR-BO500	695
	WH9-HYTRX	rear HG type FW body+brake shoes BR-BO500X	734

RIM

FRONT RIM REAR RIM LABEL KIT VALVE HOLE DIAMETER TYRE BRAKE SHOES	WH-201HY (with labels) WH-202HY (with labels) LAB-HYT9 (for a pair of front+rear wheels) 6,5 mm 634 mm See recommended tyre manufacturer inflation pressure for carbon rims - BR-BO500 (for Campagnolo brakes) - BR-BO500X (for Shimano brakes)
-------------------------------------------------------------------------------------	-------------------------------------------------------------------------------------------------------------------------------------------------------------------------------------------------------------------------------------------------------------------

HUBS

Labels for front hub: HB-BO027, HB-BO019, 4-HB-RE021, 4-HB-HY123 (ceramic), 4-HB-HY024, 4-HB-HY024, 4-HB-HY123 (ceramic), 4-HB-RE021, 4-HB-HY022, 4-HB-RE018, HB-RE020, 4-HB-HY022, 3-HB-BO011, HB-BO101, 3-HB-BO011.

Labels for rear hub: FH-BO027, HB-BO019, 4-HB-RE021, 4-HB-HY123 (ceramic), 4-HB-HY024, 4-HB-HY123 (ceramic), 4-HB-RE021, FH-BO021, HB-RE020, 4-HB-HY022, 4-HB-HY024, FH-SH017, 3-HB-BO011, 4-HB-HY022, FH-BO001, 5-FH-RE114, 3-FH-BO013, FH-BUU015, FH-BUU015X, 5-FH-RE114, 3-FH-RE113, FH-RE126 (Campy 9/11) (HG 8/10).

HB-HY100 CULT™ KIT

- 2 x HB-RE021
- 2 x HB-HY022
- 2 x HB-HY024
- 2 x HB-HY123

QUICK-RELEASES	QR12-BUUBFR	front + rear
----------------	-------------	--------------

SPOKES		
COMPLETE FRONT KIT	KIT-01HY	22 front spokes + 22 nuts + 22 nut supporting plates
COMPLETE REAR KIT	KIT-02HY	12 rear right spokes + 12 rear left spokes + 24 nuts + 24 nut supporting plates + 12 barrels
MINI-KIT	KIT-100HY	2 front spokes + 2 rear right spokes + 2 rear left spokes + 6 nuts + 6 nut supporting plates + 2 barrels
NUTS	10-WH-010BO	10 pieces
NUT SUPPORTING PLATES	10-WH-011HY	10 pieces

NOTES

⚠ WARNING!
Because of the high temperatures reached when braking, we recommend you use only glue for tubular tires specifically for carbon fibre rims.

KHAMSIN™ clincher

MEDIUM PROFILE

INTENDED USE	WHEEL CODES	DESCRIPTION	WEIGHT	
This product has been designed and manufactured to be fitted and used only on "racing" or "cyclocross" bikes (if they bear the CX mark), and any other use is expressly excluded. Any other use of this product (like, for instance, cross country, all mountain-enduro, acrobatic off-road, downhill, fourcross, freeride, free-style or any other type of extreme off-road cycling as defined by UCI) can cause accidents, injuries and even death and is therefore expressly forbidden	WH11-KHCFRB	FRONT+REAR Campagnolo FW body	1.873	
	WH12-KHCFRXB	FRONT+REAR HG type FW body	1.912	
	WH11-KHCFB	front	828	
	WH11-KHCRB	rear Campagnolo FW body	1.045	
	WH12-KHCRXB	rear HG type FW body	963	
	RED&BLACK			
	WH12-KHCFRRB	FRONT+REAR Campagnolo FW body	1.873	
	WH12-KHCFRXRB	FRONT+REAR HG type FW body	1.912	
	WH12-KHCFRB	front	828	
	WH12-KHCRRB	rear Campagnolo FW body	1.045	
WH12-KHCRXRB	rear HG type FW body	963		

RIM

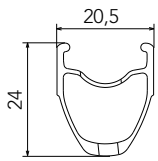

RIM-TAPE
LABEL KIT
VALVE HOLE
DIAMETER
TYRE SECTION

2-WH-RT01 (18 mm - 2 pieces)
LAB-KHCB11 (BLACK - front+rear) - LAB-KHCRB12 (RED&BLACK - front+rear)
6,5 mm
700C (622 x 15C)
See section table and inflation pressures on page 205

HUBS

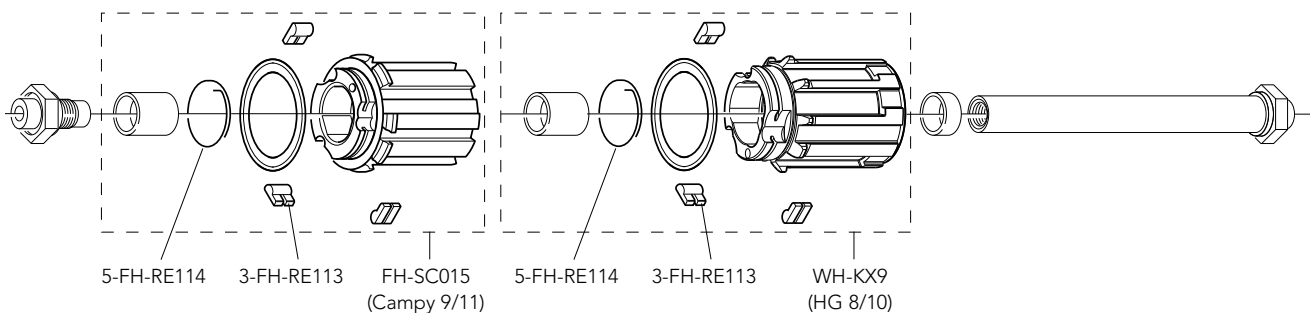
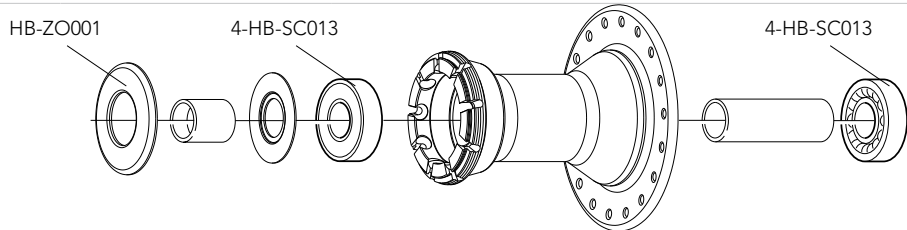
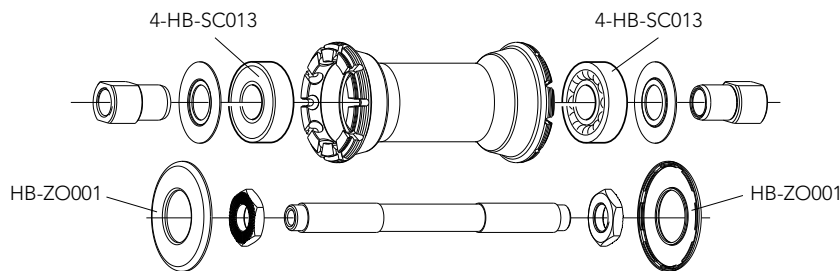

QUICK-RELEASES	QR8-40BFR QR12-40RFR	black - front + rear red - front + rear
----------------	-------------------------	--------------------------------------------

SPOKES

COMPLETE FRONT KIT	KIT-23KHB	24 front spokes + 24 nipples
COMPLETE REAR KIT	KIT-24KHB	18 rear right spokes + 9 rear left spokes + 27 nipples
MINI-KIT	KIT-300KHB	2 front spokes + 2 rear right spokes + 2 rear left spokes + 6 nipples
NIPPLES	50-WH-NZO	50 pieces

NOTES

--	--	--

VENTO™ REACTION™ clincher

MEDIUM PROFILE

INTENDED USE	WHEEL CODES	DESCRIPTION	WEIGHT
This product has been designed and manufactured to be fitted and used only on "racing" or "cyclocross" bikes (if they bear the CX mark), and any other use is expressly excluded. Any other use of this product (like, for instance, cross country, all mountain-enduro, acrobatic off-road, downhill, fourcross, freeride, free-style or any other type of extreme off-road cycling as defined by UCI) can cause accidents, injuries and even death and is therefore expressly forbidden	WH10-VECFRB	FRONT+REAR Campagnolo FW body	1.827
	WH12-VECFRXB	FRONT+REAR HG type FW body	1.866
	WH10-VECFB	front	825
	WH10-VECRB	rear Campagnolo FW body	1.002
	WH12-VECRXB	rear HG type FW body	1.041

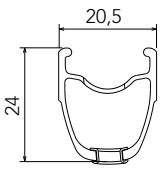
RIM			
	RIM-TAPE LABEL KIT VALVE HOLE DIAMETER TYRE SECTION	2-WH-RT01 (18 mm - 2 pieces)	
		LAB-VECB11 (for a pair of front+rear wheels) 6,5 mm 700C (622 x 15C) See section table and inflation pressures on page 205	

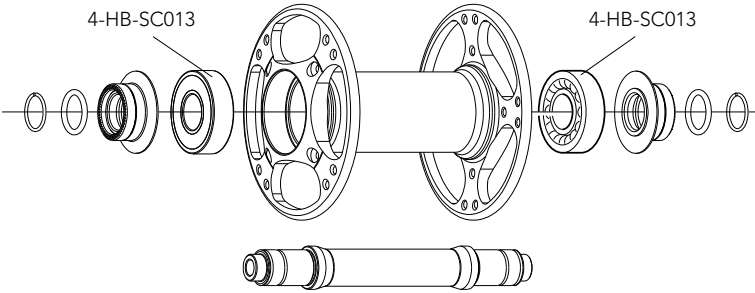
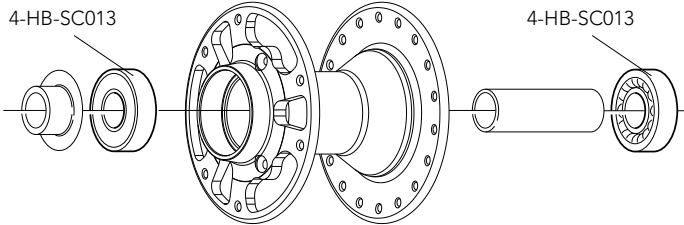
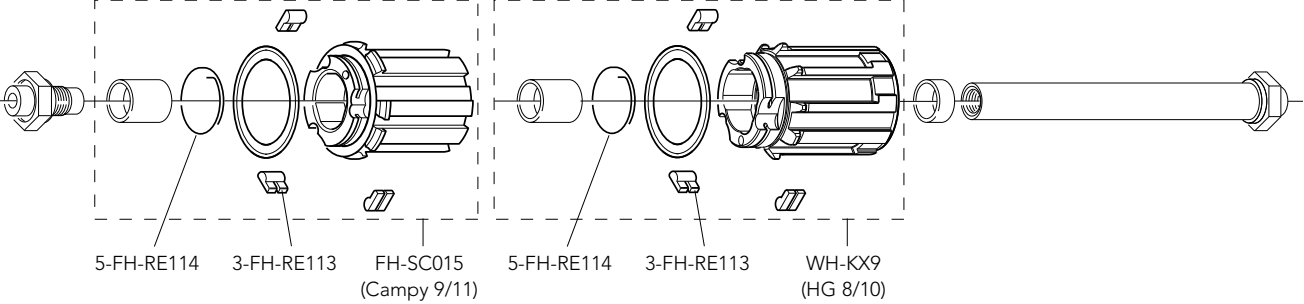
HUBS			
			
			
			
QUICK-RELEASES	QR8-40BFR	front + rear	

SPOKES			
COMPLETE FRONT KIT	KIT-23VEB	23 front spokes + 1 balancing spoke + 24 nipples	
COMPLETE REAR KIT	KIT-34VEB	18 rear right spokes + 8 rear left spokes + 1 rear left balancing spoke + 27 nipples	
MINI-KIT	KIT-700VEB	3 front spokes + 5 rear spokes + 7 nipples	
NIPPLES	50-WH-NZO	50 pieces	

NOTES			

SCIROCCO™ clincher

MEDIUM PROFILE

INTENDED USE	WHEEL CODES	DESCRIPTION	WEIGHT
This product has been designed and manufactured to be fitted and used only on "racing" or "cyclocross" bikes (if they bear the CX mark), and any other use is expressly excluded. Any other use of this product (like, for instance, cross country, all mountain-enduro, acrobatic off-road, downhill, fourcross, freeride, free-style or any other type of extreme off-road cycling as defined by UCI) can cause accidents, injuries and even death and is therefore expressly forbidden	WH10-SCCFRB	FRONT+REAR Campagnolo FW body	1.795
	WH12-SCCFRXB	FRONT+REAR HG type FW body	1.834
	WH10-SCCFB	front	775
	WH10-SCCRB	rear Campagnolo FW body	1.020
	WH12-SCCRXB	rear HG type FW body	1.059

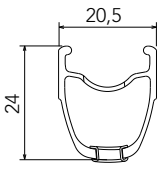
RIM			
	RIM-TAPE LABEL KIT VALVE HOLE DIAMETER TYRE SECTION	2-WH-RT01 (18 mm - 2 pieces)	
		LAB-SCCB11 (for a pair of front+rear wheels) 6,5 mm 700C (622 x 15C) See section table and inflation pressures on page 205	

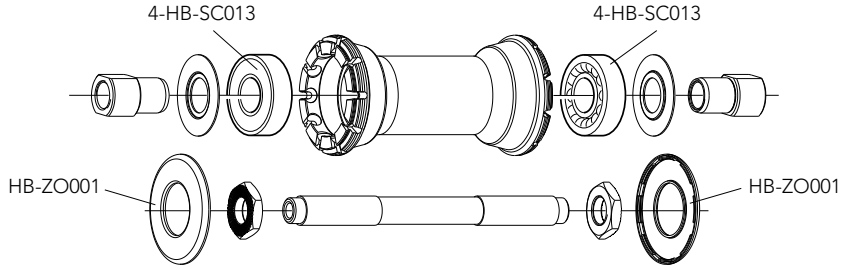
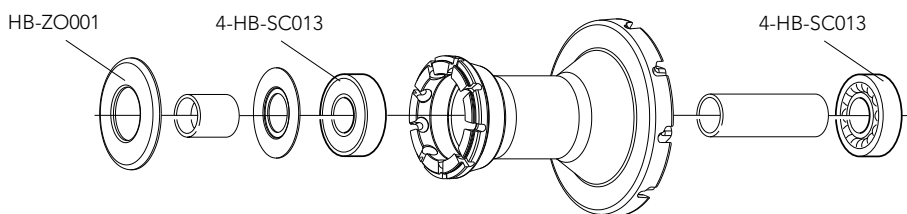
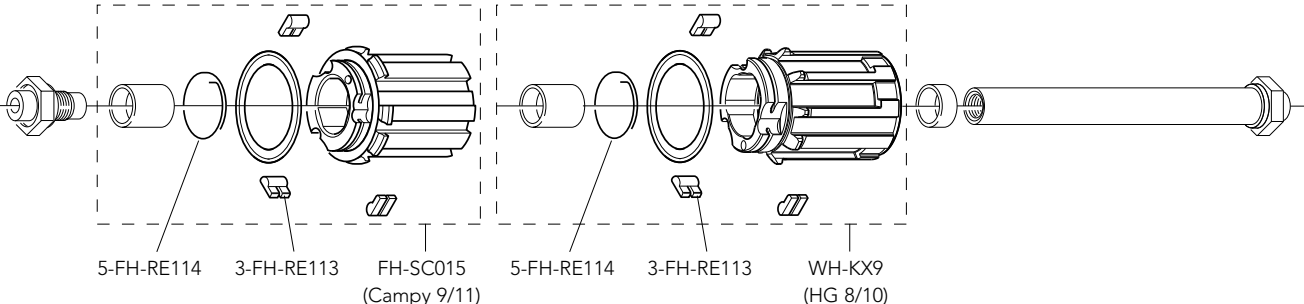
HUBS			
			
			
			

QUICK-RELEASES	QR12-ZOBFR	front + rear
----------------	------------	--------------

SPOKES			
COMPLETE FRONT KIT	KIT-43SCB	16 front spokes + 16 nipples	
COMPLETE REAR KIT	KIT-44SCB	14 rear right spokes + 7 rear left spokes + 21 nipples	
MINI-KIT	KIT-700SCB	2 front spokes + 2 rear right spokes + 2 rear left spokes + 6 nipples	
NIPPLES	50-WH-NZO	50 pieces	

NOTES			

ZONDA™ clincher

MEDIUM PROFILE

INTENDED USE	WHEEL CODES	DESCRIPTION	WEIGHT
This product has been designed and manufactured to be fitted and used only on "racing" or "cyclocross" bikes (if they bear the CX mark), and any other use is expressly excluded. Any other use of this product (like, for instance, cross country, all mountain-enduro, acrobatic off-road, downhill, fourcross, freeride, free-style or any other type of extreme off-road cycling as defined by UCI) can cause accidents, injuries and even death and is therefore expressly forbidden	WH10-ZOCFRB	FRONT+REAR Campagnolo FW body	1.555
	WH10-ZOCFRXB	FRONT+REAR HG type FW body	1.594
	WH10-ZOCFB	front	670
	WH10-ZOCRB	rear Campagnolo FW body	885
	WH10-ZOCRXB	rear HG type FW body	924

RIM			
	<p>FRONT RIM REAR RIM LABEL KIT VALVE HOLE DIAMETER TYRE SECTION</p>	<p>WH-303ZOB (with labels) WH-304ZOB (with labels) LAB-ZOCB10 (for a pair of front+rear wheels) 6,5 mm 622 X 15C See section table and inflation pressures on page 205</p>	

HUBS			
			<div style="border: 1px solid black; padding: 5px;"> <p>HB-RE100 HUB KIT</p> <p>2 x HB-RE021 2 x HB-RE022 2 x HB-RE124 2 x HB-RE023</p> </div>
QUICK-RELEASES	QR12-ZOBFR	front + rear	

SPOKES			
COMPLETE FRONT KIT	KIT-33ZOB	16 front spokes + 16 nipples	
COMPLETE REAR KIT	KIT-34ZOB	14 rear right spokes + 7 rear left spokes + 21 nipples	
MINI-KIT	KIT-500ZOB	2 front spokes + 2 rear right spokes + 2 rear left spokes + 6 nipples	
NIPPLES	50-WH-NZO	50 pieces	
SPOKE RING	UT-WH010	anti-rotation spokes	
INSERT NIPPLE	UT-WH030	magnet-attractor for nipple	
NIPPLE MAGNET	UT-WH050	nipple-guide	
SPOKE SPANNER	UT-WH070	spoke wrenches	

NOTES

EURUS™ clincher

MEDIUM PROFILE

INTENDED USE	WHEEL CODES	DESCRIPTION	WEIGHT
This product has been designed and manufactured to be fitted and used only on "racing" or "cyclocross" bikes (if they bear the CX mark), and any other use is expressly excluded. Any other use of this product (like, for instance, cross country, all mountain-enduro, acrobatic off-road, downhill, fourcross, freeride, free-style or any other type of extreme off-road cycling as defined by UCI) can cause accidents, injuries and even death and is therefore expressly forbidden	WH12-EUCFRB	FRONT+REAR Campagnolo FW body	1.482
	WH12-EUCFRXB	FRONT+REAR HG type FW body	1.521
	WH12-EUCFB	front	634
	WH12-EUCRB	rear Campagnolo FW body	848
	WH12-EUCRXB	rear HG type FW body	887

RIM			
	<p>FRONT RIM REAR RIM LABEL KIT VALVE HOLE DIAMETER TYRE SECTION</p>	<p>WH-503EUB (with labels) WH-504EUB (with labels) LAB-EUCB12 (for a pair of front+rear wheels) 6,5 mm 622 X 15C See section table and inflation pressures on page 205</p>	

HUBS			
			<div style="border: 1px solid black; padding: 5px;"> <p>HB-RE100 HUB KIT</p> <p>2 x HB-RE021 2 x HB-RE022 2 x HB-RE124 2 x HB-RE023</p> </div>
QUICK-RELEASES	QR11-20BFR	front + rear	

SPOKES			
COMPLETE FRONT KIT.	KIT-13SHB	16 front/rear left spokes + 16 nipples	
COMPLETE REAR KIT.	KIT-24SHB	14 rear right spokes + 7 front/rear left spokes + 21 nipples	
COMPLETE FRONT/REAR LEFT SPOKE	WH-105SHB	spoke + nipples	
COMPLETE REAR RIGHT SPOKE	WH-107SHB	spoke + nipples	
NIPPLES	10-WH-015SH	10 pieces	
SPOKE RING	UT-WH010	anti-rotation spokes	
INSERT NIPPLE	UT-WH030	magnet-attractor for nipple	
NIPPLE MAGNET	UT-WH050	nipple-guide	
SPOKE SPANNER	UT-WH070	spoke wrenches	

NOTES

SHAMAL™ ULTRA™ clincher

MEDIUM PROFILE

INTENDED USE	WHEEL CODES	DESCRIPTION	WEIGHT	
This product has been designed and manufactured to be fitted and used only on "racing" or "cyclocross" bikes (if they bear the CX mark), and any other use is expressly excluded. Any other use of this product (like, for instance, cross country, all mountain-enduro, acrobatic off-road, downhill, fourcross, freeride, free-style or any other type of extreme off-road cycling as defined by UCI) can cause accidents, injuries and even death and is therefore expressly forbidden	WH12-SHCFRB	FRONT+REAR Campagnolo FW body	1.425	
	WH12-SHCFRXB	FRONT+REAR HG type FW body	1.464	
	WH12-SHCFB	front	605	
	WH12-SHCRB	rear Campagnolo FW body	820	
	WH12-SHCRXB	rear HG type FW body	859	
	DARK LABEL			
	WH12-SHCFRBDK	FRONT+REAR Campagnolo FW body	1.425	
	WH12-SHCFRXBDK	FRONT+REAR HG type FW body	1.464	
	WH12-SHCFBDK	front	605	
	WH12-SHCRBDK	rear Campagnolo FW body	820	
WH12-SHCRXBDK	rear HG type FW body	859		

RIM	
<p>FRONT 20,5 REAR 20,5 25 30</p> <p>FRONT RIM REAR RIM LABEL KIT VALVE HOLE DIAMETER TYRE SECTION</p>	<p>WH-203SHB (with standard labels) - WH-203SHBDK (with DARK labels) WH-204SHB (with standard labels) - WH-204SHBDK (with DARK labels) LAB-SHCB12 (front+rear) - LAB-SHCB12DK (front+rear DARK) 6,5 mm 622 X 15C See section table and inflation pressures on page 205</p>

HUBS		
<p>(Campy 9/11) (HG 8/10)</p>		
QUICK-RELEASES	QR11-20BFR	front + rear

SPOKES		
<p>COMPLETE FRONT KIT. COMPLETE REAR KIT. COMPLETE FRONT/REAR LEFT SPOKE COMPLETE REAR RIGHT SPOKE NIPPLES SPOKE RING INSERT NIPPLE NIPPLE MAGNET SPOKE SPANNER</p>	<p>KIT-13SHB KIT-24SHB WH-105SHB WH-107SHB 10-WH-015SH UT-WH010 UT-WH030 UT-WH050 UT-WH070</p>	<p>16 front/rear left spokes + 16 nipples 14 rear right spokes + 7 front/rear left spokes + 21 nipples spoke + nipples spoke + nipples 10 pieces anti-rotation spokes magnet-attractor for nipple nipple-guide spoke wrenches</p>

SHAMAL™ ULTRA™ tubular

MEDIUM PROFILE

INTENDED USE	WHEEL CODES	DESCRIPTION	WEIGHT
This product has been designed and manufactured to be fitted and used only on "racing" or "cyclocross" bikes (if they bear the CX mark), and any other use is expressly excluded. Any other use of this product (like, for instance, cross country, all mountain-enduro, acrobatic off-road, downhill, fourcross, freeride, free-style or any other type of extreme off-road cycling as defined by UCI) can cause accidents, injuries and even death and is therefore expressly forbidden	WH12-SHTFRB	FRONT+REAR Campagnolo FW body	1.440
	WH12-SHTFRXB	FRONT+REAR HG type FW body	1.479
	WH12-SHTFB	front	615
	WH12-SHTRB	rear Campagnolo FW body	825
	WH12-SHTRXB	rear HG type FW body	864

RIM			
	<p>FRONT RIM REAR RIM LABEL KIT VALVE HOLE DIAMETER TYRE SECTION</p>	<p>WH-201SHB (with labels) WH-202SHB (with labels) LAB-SHCB12 (for a pair of front+rear wheels) 6,5 mm 634 mm See recommended tyre manufacturer inflation pressure</p>	

HUBS			
QUICK-RELEASES	QR11-20BFR	front + rear	

SPOKES			
<p>COMPLETE FRONT KIT. COMPLETE REAR KIT. COMPLETE FRONT/REAR LEFT SPOKE COMPLETE REAR RIGHT SPOKE NIPPLES SPOKE RING INSERT NIPPLE NIPPLE MAGNET SPOKE SPANNER</p>	<p>KIT-13SHB KIT-24SHB WH-105SHB WH-107SHB 10-WH-015SH UT-WH010 UT-WH030 UT-WH050 UT-WH070</p>	<p>16 front/rear left spokes + 16 nipples 14 rear right spokes + 7 front/rear left spokes + 21 nipples spoke + nipples spoke + nipples 10 pieces anti-rotation spokes magnet-attractor for nipple nipple-guide spoke wrenches</p>	

NOTES

ZONDA™ 2-Way Fit™

MEDIUM PROFILE

INTENDED USE	WHEEL CODES	DESCRIPTION	WEIGHT
This product has been designed and manufactured to be fitted and used only on "racing" or "cyclocross" bikes (if they bear the CX mark), and any other use is expressly excluded. Any other use of this product (like, for instance, cross country, all mountain-enduro, acrobatic off-road, downhill, fourcross, freeride, free-style or any other type of extreme off-road cycling as defined by UCI) can cause accidents, injuries and even death and is therefore expressly forbidden	WH10-ZO2FRB	FRONT+REAR Campagnolo FW body	1.580
	WH10-ZO2FRXB	FRONT+REAR HG type FW body	1.619
	WH10-ZO2FB	front	680
	WH10-ZO2RB	rear Campagnolo FW body	900
	WH10-ZO2RXB	rear HG type FW body	939

RIM			
	<p>FRONT RIM REAR RIM LABEL KIT VALVE HOLE 2-WAY FIT™ VALVE VALVE HOLE BUSHING DIAMETER TYRE SECTION</p>	<p>WH-013ZOB (with labels) WH-014ZOB (with labels) LAB-ZO2B10 (for a pair of front+rear wheels) 6,5 mm WH-SH001 5-WH-SH002 (for valve seat reduction - 5 pieces) 634 mm See recommended tyre manufacturer inflation pressure</p>	

HUBS			
	<p>HB-BO027 HB-ZO019 4-HB-RE021 4-HB-RE023 (steel) 4-HB-RE124 HB-EU025 HB-EU025 4-HB-RE124 4-HB-RE023 (steel)</p> <p>4-HB-RE018 HB-RE020 4-HB-RE022 4-HB-RE022 4-HB-RE021</p> <p>HB-ZO002 HB-BO101 HB-ZO001</p>		
	<p>FH-BO027 HB-ZO019 4-HB-RE021 4-HB-RE023 (steel) HB-EU025 HB-EU025 4-HB-RE124 4-HB-RE021</p> <p>FH-BO021 HB-RE020 4-HB-RE022 4-HB-RE124 4-HB-RE023 (steel)</p> <p>HB-ZO002 4-HB-RE022 FH-BO001 5-FH-RE114 3-FH-BO013 FH-BUU015 FH-BUU015X 5-FH-RE114 3-FH-RE113 FH-RE126</p> <p>(Campy 9/11) (HG 8/10)</p>	<p>HB-RE100 HUB KIT 2 x HB-RE021 2 x HB-RE022 2 x HB-RE124 2 x HB-RE023</p>	
QUICK-RELEASES	QR11-20BFR	front + rear	

SPOKES			
COMPLETE FRONT KIT	KIT-33ZOB	16 front spokes + 16 nipples	
COMPLETE REAR KIT	KIT-34ZOB	14 rear right spoke + 7 SPOKES post sx + 21 nipples	
MINI-KIT	KIT-500ZOB	2 front spokes + 2 rear right spokes + 2 rear left spokes + 6 nipples	
NIPPLES	50-WH-NZO	50 pieces	
SPOKE RING	UT-WH010	anti-rotation spokes	
INSERT NIPPLE	UT-WH030	magnet-attractor for nipple	
NIPPLE MAGNET	UT-WH050	nipple-guide	
SPOKE SPANNER	UT-WH070	spoke wrenches	

NOTES

EURUS 2-Way Fit™

MEDIUM PROFILE

INTENDED USE	WHEEL CODES	DESCRIPTION	WEIGHT
This product has been designed and manufactured to be fitted and used only on "racing" or "cyclocross" bikes (if they bear the CX mark), and any other use is expressly excluded. Any other use of this product (like, for instance, cross country, all mountain-enduro, acrobatic off-road, downhill, fourcross, freeride, free-style or any other type of extreme off-road cycling as defined by UCI) can cause accidents, injuries and even death and is therefore expressly forbidden	WH12-EU2FRB	FRONT+REAR Campagnolo FW body	1.500
	WH12-EU2FRXB	FRONT+REAR HG type FW body	1.539
	WH12-EU2FB	front	643
	WH12-EU2RB	rear Campagnolo FW body	857
	WH12-EU2RXB	rear HG type FW body	896

RIM			
	<p>FRONT RIM REAR RIM LABEL KIT VALVE HOLE 2-WAY FIT™ VALVE VALVE HOLE BUSHING DIAMETER TYRE SECTION</p>	<p>WH-113EUB (with labels) WH-114EUB (with labels) LAB-EU2B12 (for a pair of front+rear wheels) 6,5 mm WH-SH001 5-WH-SH002 (for valve seat reduction - 5 pieces) 634 mm See recommended tyre manufacturer inflation pressure</p>	

HUBS			
	<p>HB-BO027 HB-ZO019 4-HB-RE021 4-HB-RE023 (steel) 4-HB-RE124 4-HB-RE018 HB-RE020 4-HB-RE022 HB-EU025 HB-EU026 4-HB-RE022 HB-BO101 HB-EU026</p>	<p>HB-EU025 4-HB-RE124 4-HB-RE023 (steel) 4-HB-RE021</p>	
	<p>FH-BO027 HB-ZO019 4-HB-RE021 4-HB-RE023 (steel) HB-EU025 FH-BO021 HB-RE020 4-HB-RE022 4-HB-RE124 FH-EU026 4-HB-RE022 FH-BO001 5-FH-RE114 3-FH-BO013 FH-BUU015 FH-BUU015X 5-FH-RE114 3-FH-RE113 FH-RE126 (Campy 9/11) (HG 8/10)</p>	<p>HB-EU025 4-HB-RE124 4-HB-RE021 4-HB-RE023 (steel)</p>	<p>HB-RE100 HUB KIT 2 x HB-RE021 2 x HB-RE022 2 x HB-RE124 2 x HB-RE023</p>

QUICK-RELEASES	QR11-20BFR	front + rear
----------------	------------	--------------

SPOKES			
<p>COMPLETE FRONT KIT. COMPLETE REAR KIT. COMPLETE FRONT/REAR LEFT SPOKE COMPLETE REAR RIGHT SPOKE NIPPLES SPOKE RING INSERT NIPPLE NIPPLE MAGNET SPOKE SPANNER</p>	<p>KIT-13SHB KIT-24SHB WH-105SHB WH-107SHB 10-WH-015SH UT-WH010 UT-WH030 UT-WH050 UT-WH070</p>	<p>16 front/rear left spokes + 16 nipples 14 rear right spokes + 7 front/rear left spokes + 21 nipples spoke + nipples spoke + nipples 10 pieces anti-rotation spokes magnet-attractor for nipple nipple-guide spoke wrenches</p>	

NOTES

INTENDED USE	WHEEL CODES	DESCRIPTION	WEIGHT	
This product has been designed and manufactured to be fitted and used only on "racing" or "cyclocross" bikes (if they bear the CX mark), and any other use is expressly excluded. Any other use of this product (like, for instance, cross country, all mountain-enduro, acrobatic off-road, downhill, fourcross, freeride, free-style or any other type of extreme off-road cycling as defined by UCI) can cause accidents, injuries and even death and is therefore expressly forbidden	WH12-SH2FRB	FRONT+REAR Campagnolo FW body	1.440	
	WH12-SH2FRXB	FRONT+REAR HG type FW body	1.479	
	WH12-SH2FB	front	615	
	WH12-SH2RB	rear Campagnolo FW body	825	
	WH12-SH2RXB	rear HG type FW body	864	
	DARK LABEL			
	WH12-SH2FRBDK	FRONT+REAR Campagnolo FW body	1.440	
	WH12-SH2FRXBDK	FRONT+REAR HG type FW body	1.479	
	WH12-SH2FBDK	front	615	
	WH12-SH2RBDK	rear Campagnolo FW body	825	
WH12-SH2RXBDK	rear HG type FW body	864		

RIM			
	<p>FRONT RIM REAR RIM LABEL KIT VALVE HOLE 2-WAY FIT™-VALVE VALVE HOLE BUSHING DIAMETER TYRE SECTION</p>	<p>WH-113SHB (with standard labels) - WH-113SHBDK (with DARK labels) WH-114SHB (with standard labels) - WH-114SHBDK (with DARK labels) LAB-SH2B12 (front+rear) - LAB-SH2B12DK (front+rear DARK) 6,5 mm WH-SH001 5-WH-SH002 (for valve seat reduction - 5 pieces) 634 mm See recommended tyre manufacturer inflation pressure</p>	

HUBS			
QUICK-RELEASES	QR11-20BFR	front + posteriore	

SPOKES			
<p>COMPLETE FRONT KIT. COMPLETE REAR KIT. COMPLETE FRONT/REAR LEFT SPOKE COMPLETE REAR RIGHT SPOKE NIPPLES SPOKE RING INSERT NIPPLE NIPPLE MAGNET SPOKE SPANNER</p>	<p>KIT-13SHB KIT-24SHB WH-105SHB WH-107SHB 10-WH-015SH UT-WH010 UT-WH030 UT-WH050 UT-WH070</p>	<p>16 front/rear left spokes + 16 nipples 14 rear right spokes + 7 front/rear left spokes + 21 nipples spoke + nipples spoke + nipples 10 pieces anti-rotation spokes magnet-attractor for nipple nipple-guide spoke wrenches</p>	

BULLET™ clincher (H50 - standard bearings)

HIGH PROFILE

INTENDED USE	WHEEL CODES	DESCRIPTION	WEIGHT
This product has been designed and manufactured to be fitted and used only on "racing" or "cyclocross" bikes (if they bear the CX mark), and any other use is expressly excluded. Any other use of this product (like, for instance, cross country, all mountain-enduro, acrobatic off-road, downhill, fourcross, freeride, free-style or any other type of extreme off-road cycling as defined by UCI) can cause accidents, injuries and even death and is therefore expressly forbidden	WH12-BUCFR	FRONT+REAR Campagnolo FW body	1.755
	WH12-BUCFRX	FRONT+REAR HG type FW body	1.794
	WH12-BUCF	front	785
	WH12-BUCR	rear Campagnolo FW body	970
	WH12-BUCRX	rear HG type FW body	1.009

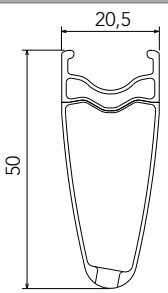
RIM	
	<p>FRONT RIM REAR RIM LABEL KIT VALVE HOLE VALVE EXTENSION DIAMETER TYRE</p> <p>WH-003BUU (no labels) WH-004BUU (no labels) LAB-BU12 (front+rear) 6,5 mm UT-WH130M (male extension) - UT-WH130F (female extension) 700C (622 x 15C) See section table and inflation pressures on page 205</p>

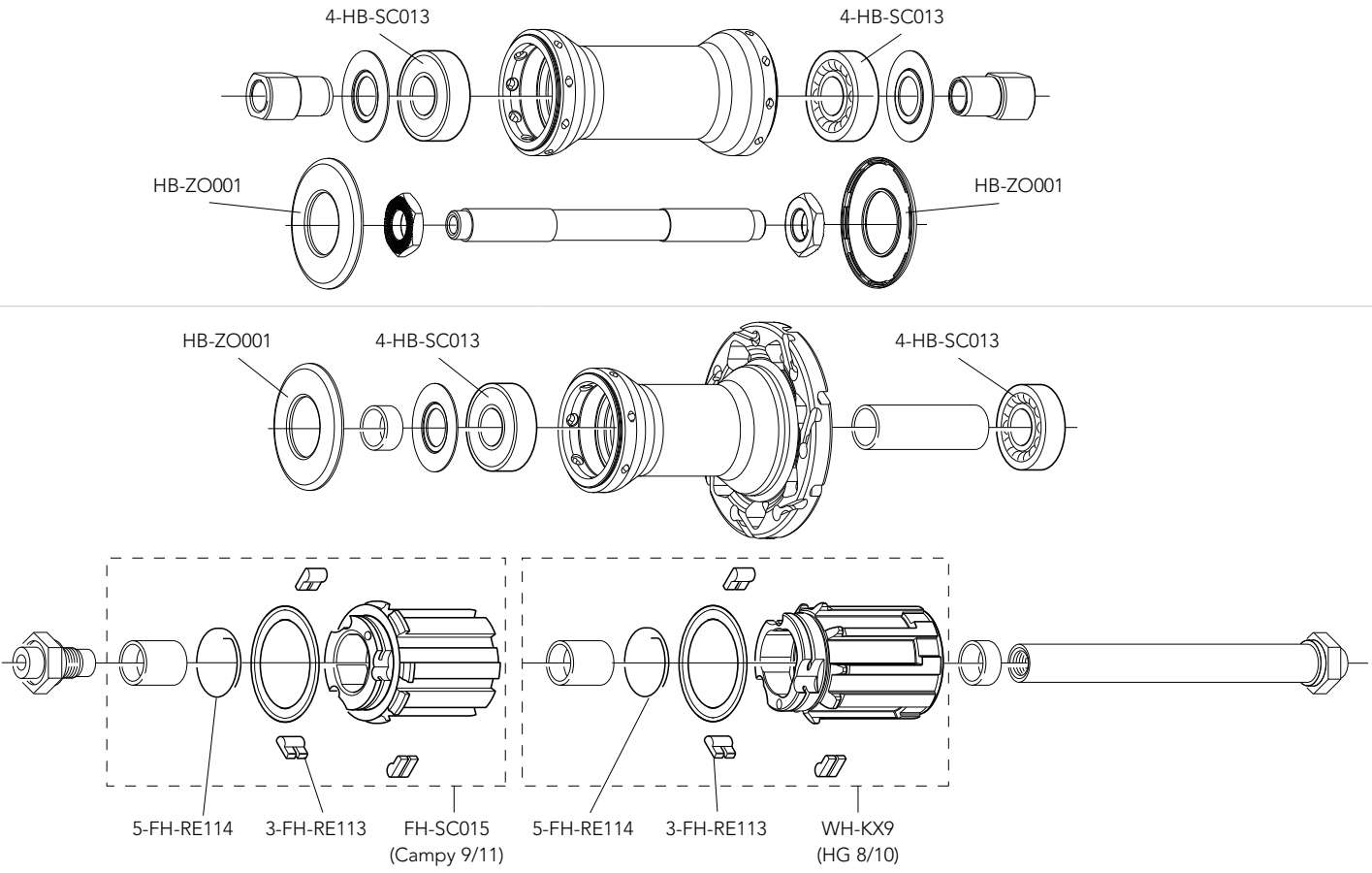
HUBS		
		
QUICK-RELEASES	QR12-ZOBFR	front + rear

SPOKES		
COMPLETE FRONT KIT	KIT-03BU	18 front spokes + 18 nuts + 18 nut supporting plates
COMPLETE REAR KIT	KIT-04BU	14 right rear spokes + 7 rear left spokes + 21 nuts + 21 nut supporting plates
MINI-KIT	KIT-500BU	2 front spokes + 2 right rear spokes + 2 rear left spokes + 6 nuts + 6 nut supporting plates
NIPPLES	WH-015BU	10 pieces
SPOKE RING	UT-WH010	anti-rotation spokes
INSERT NIPPLE	UT-WH160	magnet-tractor for nipple
NIPPLE MAGNET	UT-WH050	nipple-guide
SPOKE SPANNER	UT-WH090	spoke wrenches

BULLET™ clincher (H50 - USB™ bearings)

HIGH PROFILE

INTENDED USE	WHEEL CODES	DESCRIPTION	WEIGHT
This product has been designed and manufactured to be fitted and used only on "racing" or "cyclocross" bikes (if they bear the CX mark), and any other use is expressly excluded. Any other use of this product (like, for instance, cross country, all mountain-enduro, acrobatic off-road, downhill, fourcross, freeride, free-style or any other type of extreme off-road cycling as defined by UCI) can cause accidents, injuries and even death and is therefore expressly forbidden	WH12-BUCFRU	FRONT+REAR Campagnolo FW body	1.755
	WH12-BUCFRXU	FRONT+REAR HG type FW body	1.794
	WH12-BUCFU	front	785
	WH12-BUCRU	rear Campagnolo FW body	970
	WH12-BUCRXU	rear HG type FW body	1.009

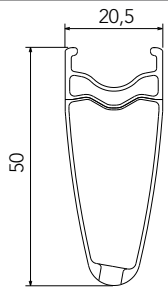
RIM		
	<p>FRONT RIM REAR RIM LABEL KIT VALVE HOLE VALVE EXTENSION DIAMETER TYRE</p>	<p>WH-003BUU (no labels) WH-004BUU (no labels) LAB-BU12 (front+rear) 6,5 mm UT-WH130M (male extension) - UT-WH130F (female extension) 700C (622 x 15C) See section table and inflation pressures on page 205</p>

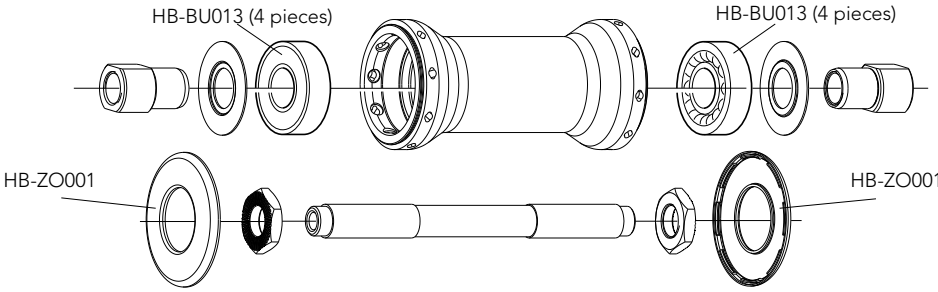
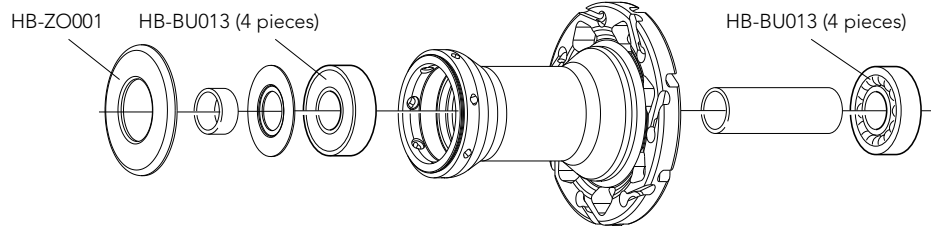
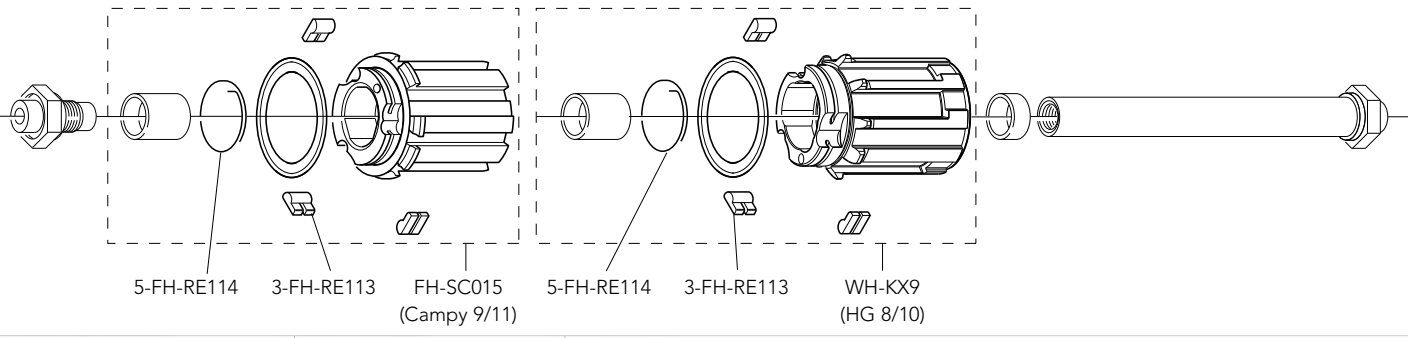
HUBS		
		
		
		
QUICK-RELEASES	QR12-ZOBFR	front + rear

SPOKES		
COMPLETE FRONT KIT	KIT-03BU	18 front spokes + 18 nuts + 18 nut supporting plates
COMPLETE REAR KIT	KIT-04BU	14 rear right spokes + 7 rear left spokes + 21 nuts + 21 nut supporting plates
MINI-KIT	KIT-500BU	2 front spokes + 2 rear right spokes + 2 rear left spokes + 6 nuts + 6 nut supporting plates
NIPPLES	WH-015BU	10 pieces
SPOKE RING	UT-WH010	anti-rotation spokes
INSERT NIPPLE	UT-WH160	magnet-attractor for nipple
NIPPLE MAGNET	UT-WH050	nipple-guide
SPOKE SPANNER	UT-WH090	spoke wrenches

BULLET™ clincher (H80 - standard bearings)

HIGH PROFILE

INTENDED USE	WHEEL CODES	DESCRIPTION	WEIGHT
This product has been designed and manufactured to be fitted and used only on "racing" or "cyclocross" bikes (if they bear the CX mark), and any other use is expressly excluded. Any other use of this product (like, for instance, cross country, all mountain-enduro, acrobatic off-road, downhill, fourcross, freeride, free-style or any other type of extreme off-road cycling as defined by UCI) can cause accidents, injuries and even death and is therefore expressly forbidden	WH12-BUCFR80	FRONT+REAR Campagnolo FW body	1.930
	WH12-BUCFRX80	FRONT+REAR HG type FW body	1.969
	WH12-BUCF80	front	865
	WH12-BUCR80	rear Campagnolo FW body	1.065
	WH12-BUCRX80	rear HG type FW body	1.104

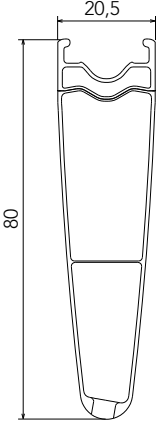
RIM			
	<p>FRONT RIM REAR RIM LABEL KIT VALVE HOLE VALVE EXTENSION DIAMETER TYRE</p>	<p>WH-003BUU80 (no labels) WH-004BUU80 (no labels) LAB-BU1280 (front+rear) 6,5 mm UT-WH140M (male extension) - UT-WH140F (female extension) 700C (622 x 15C) See section table and inflation pressures on page 205</p>	

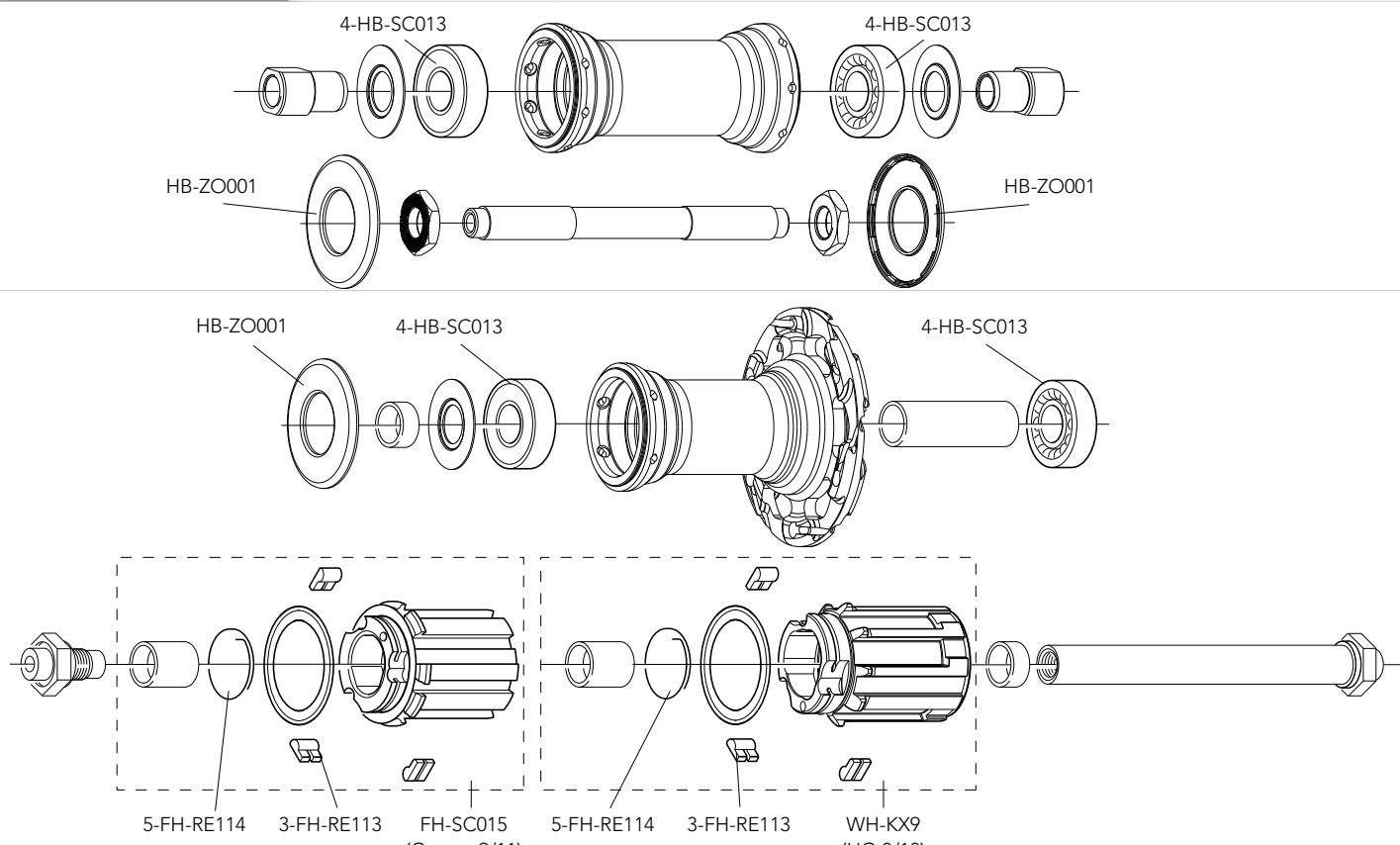
HUBS			
			
QUICK-RELEASES	QR12-ZOBFR	front + rear	

SPOKES			
<p>COMPLETE FRONT KIT COMPLETE REAR KIT MINI-KIT NIPPLES SPOKE RING INSERT NIPPLE NIPPLE MAGNET SPOKE SPANNER</p>	<p>KIT-03BU80 KIT-04BU80 KIT-500BU80 WH-015BU UT-WH010 UT-WH160 UT-WH050 UT-WH090</p>	<p>16 front spokes + 16 nuts + 16 nut supporting plates 12 rear right spokes + 6 rear left spokes + 18 nuts + 18 nut supporting plates 2 front spokes + 2 rear right spokes + 2 rear left spokes + 6 nuts + 6 nut supporting plates 10 pieces anti-rotation spokes magnet-attractor for nipple nipple-guide spoke wrenches</p>	

BULLET™ clincher (H80 - USB™ bearings)

HIGH PROFILE

INTENDED USE	WHEEL CODES	DESCRIPTION	WEIGHT
This product has been designed and manufactured to be fitted and used only on "racing" or "cyclocross" bikes (if they bear the CX mark), and any other use is expressly excluded. Any other use of this product (like, for instance, cross country, all mountain-enduro, acrobatic off-road, downhill, fourcross, freeride, free-style or any other type of extreme off-road cycling as defined by UCI) can cause accidents, injuries and even death and is therefore expressly forbidden	WH12-BUCFRU80	FRONT+REAR Campagnolo FW body	1.930
	WH12-BUCFRXU80	FRONT+REAR HG type FW body	1.969
	WH12-BUCFU80	front	865
	WH12-BUCRU80	rear Campagnolo FW body	1.065
	WH12-BUCRXU80	rear HG type FW body	1.104

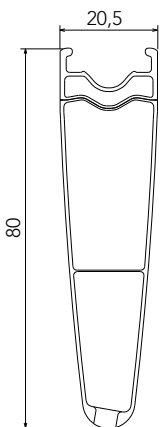
RIM		
	<p>FRONT RIM REAR RIM LABEL KIT VALVE HOLE VALVE EXTENSION DIAMETER TYRE</p>	<p>WH-003BUU80 (no labels) WH-004BUU80 (no labels) LAB-BU1280 (front+rear) 6,5 mm UT-WH140M (male extension) - UT-WH140F (female extension) 700C (622 x 15C) See section table and inflation pressures on page 205</p>

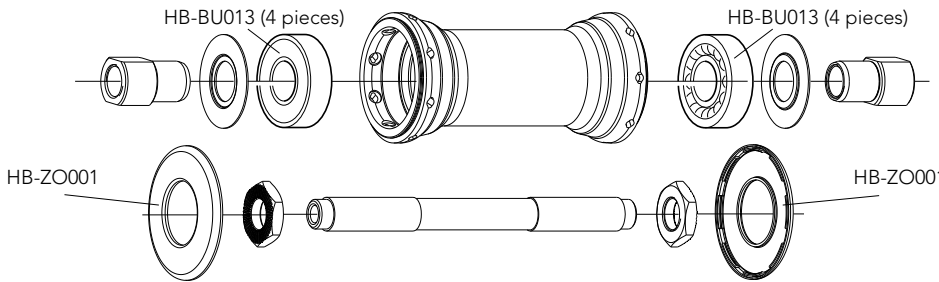
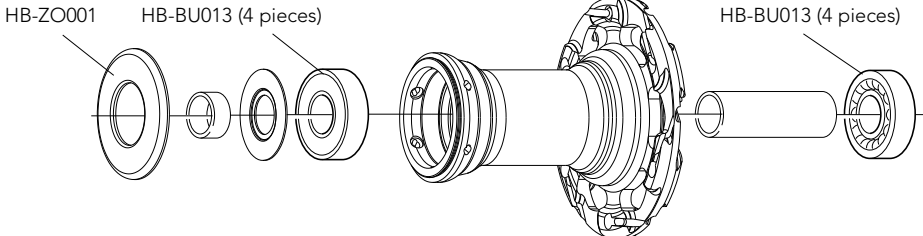
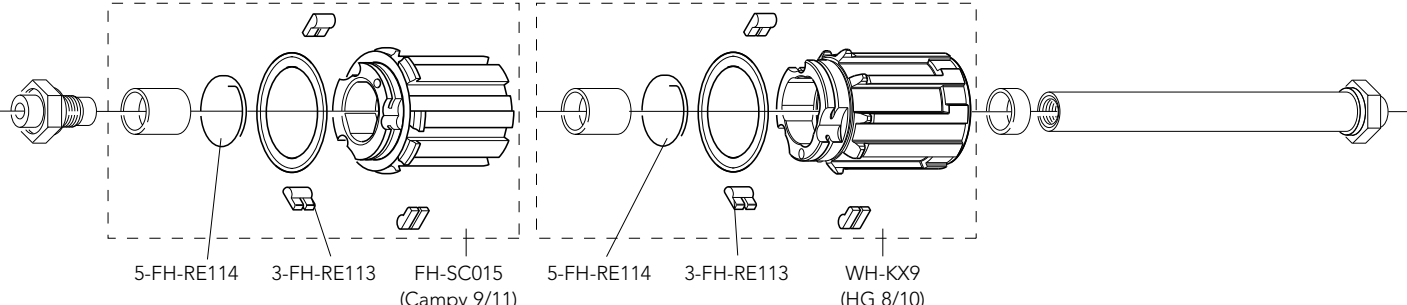
HUBS		
		
		
		

QUICK-RELEASES	QR12-ZOBFR	front + rear
----------------	------------	--------------

SPOKES		
COMPLETE FRONT KIT	KIT-03BU	18 front spokes + 18 nuts + 18 nut supporting plates
COMPLETE REAR KIT	KIT-04BU	14 rear right spokes + 7 rear left spokes + 21 nuts + 21 nut supporting plates
MINI-KIT	KIT-500BU	2 front spokes + 2 rear right spokes + 2 rear left spokes + 6 nuts + 6 nut supporting plates
NIPPLES	WH-015BU	10 pieces
SPOKE RING	UT-WH010	anti-rotation spokes
INSERT NIPPLE	UT-WH160	magnet-attractor for nipple
NIPPLE MAGNET	UT-WH050	nipple-guide
SPOKE SPANNER	UT-WH090	spoke wrenches

MAXIMUM OPERATING PRESSURE

			RIM DIMENSION			
			13C		15C	
			mm	in.	BAR	PSI
TYRE WIDTH	18	0,70	10,0	146		
	20	0,80	9,5	138		
	23	0,90	9,5	138	9,5	138
	25	1,00	9,0	131	9,0	131
	28	1,10			8,0	117
	30	1,20			7,0	103
	32	1,25			6,7	99
	35	1,30			6,3	93

BULLET™ ULTRA clincher (H50 - standard bearings)

HIGH PROFILE

INTENDED USE	WHEEL CODES	DESCRIPTION	WEIGHT	
This product has been designed and manufactured to be fitted and used only on "racing" or "cyclocross" bikes (if they bear the CX mark), and any other use is expressly excluded. Any other use of this product (like, for instance, cross country, all mountain-enduro, acrobatic off-road, downhill, fourcross, freeride, free-style or any other type of extreme off-road cycling as defined by UCI) can cause accidents, injuries and even death and is therefore expressly forbidden	WH12-BUUCFR	FRONT+REAR Campagnolo FW body	1.590	
	WH12-BUUCFRX	FRONT+REAR HG type FW body	1.629	
	WH12-BUUCF	front	727	
	WH12-BUUCR	rear Campagnolo FW body	863	
	WH12-BUUCRX	rear HG type FW body	902	
	DARK LABEL			
	WH12-BUUCFRDK	FRONT+REAR Campagnolo FW body	1.590	
	WH12-BUUCFRXDK	FRONT+REAR HG type FW body	1.629	
	WH12-BUUCFDK	front	727	
	WH12-BUUCRDK	rear Campagnolo FW body	863	
WH12-BUUCRXDK	rear HG type FW body	902		

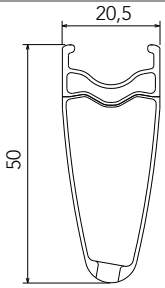
RIM		
	FRONT RIM REAR RIM LABEL KIT VALVE HOLE VALVE EXTENSION DIAMETER TYRE	WH-003BUU (no labels) WH-004BUU (no labels) LAB-BUU12 (front+rear) - LAB-BUU12DK (front+rear DARK) 6,5 mm UT-WH130M (male extension) - UT-WH130F (female extension) 700C (622 x 15C) See section table and inflation pressures on page 205

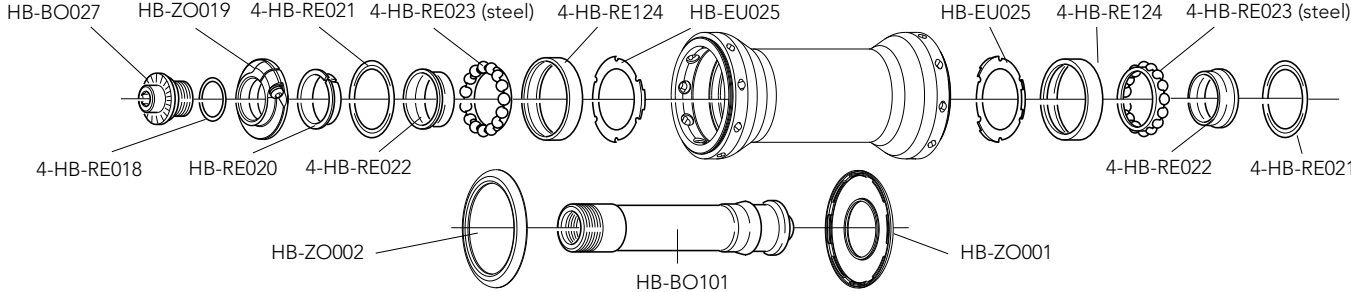
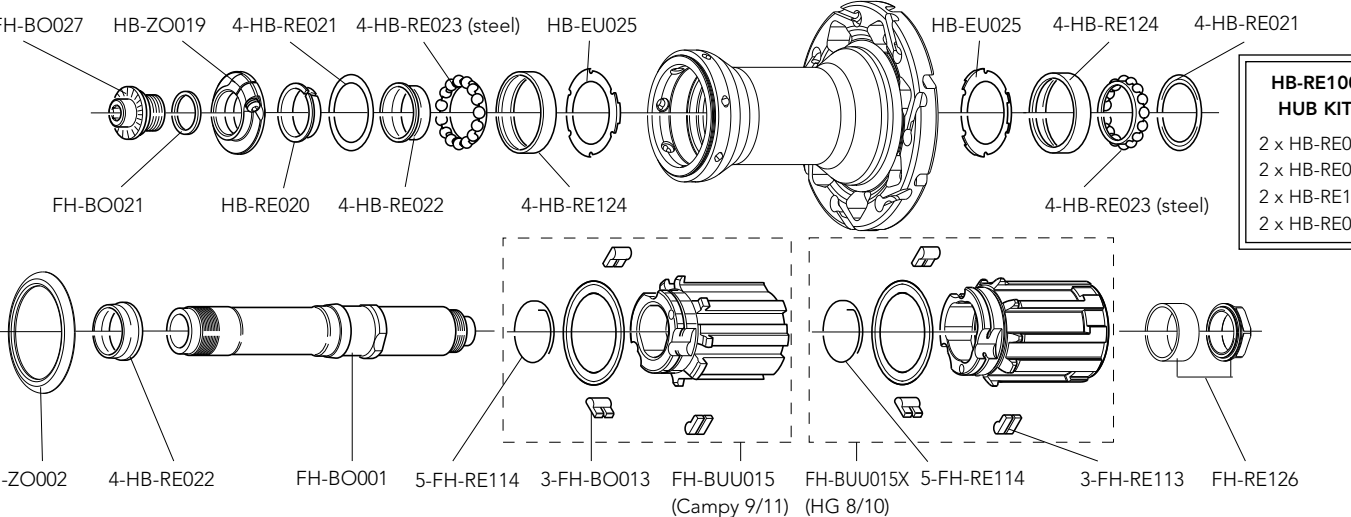
HUBS		
		
	HB-RE100 HUB KIT 2 x HB-RE021 2 x HB-RE022 2 x HB-RE124 2 x HB-RE023	(Campy 9/11) (HG 8/10)
QUICK-RELEASES	QR12-BUUBFR	front + rear

SPOKES		
COMPLETE FRONT KIT	KIT-03BUU	18 front spokes + 18 nuts + 18 nut supporting plates
COMPLETE REAR KIT	KIT-04BUU	14 rear right spokes + 7 rear left spokes + 21 nuts + 21 nut supporting plates
MINI-KIT	KIT-500BUU	2 front spokes + 2 rear right spokes + 2 rear left spokes + 6 nuts + 6 nut supporting plates
NIPPLES	WH-015BUU	red - 10 pieces
SPOKE RING	UT-WH010	anti-rotation spokes
INSERT NIPPLE	UT-WH160	magnet-attractor for nipple
NIPPLE MAGNET	UT-WH050	nipple-guide
SPOKE SPANNER	UT-WH090	spoke wrenches

NOTES

BULLET™ ULTRA clincher (H50 - USB™ bearings)
HIGH PROFILE

INTENDED USE	WHEEL CODES	DESCRIPTION	WEIGHT
This product has been designed and manufactured to be fitted and used only on "racing" or "cyclocross" bikes (if they bear the CX mark), and any other use is expressly excluded. Any other use of this product (like, for instance, cross country, all mountain-enduro, acrobatic off-road, downhill, fourcross, freeride, free-style or any other type of extreme off-road cycling as defined by UCI) can cause accidents, injuries and even death and is therefore expressly forbidden	WH12-BUUCFRU	FRONT+REAR Campagnolo FW body - USB	1.590
	WH12-BUUCFRXU	FRONT+REAR HG type FW body - USB	1.629
	WH12-BUUCFU	front - USB	727
	WH12-BUUCRU	rear Campagnolo FW body - USB	863
	WH12-BUUCRXU	rear HG type FW body - USB	902
	DARK LABEL		
	WH12-BUUCFRUDK	FRONT+REAR Campagnolo FW body - USB	1.590
	WH12-BUUCFRXUDK	FRONT+REAR HG type FW body - USB	1.629
	WH12-BUUCFUDK	front - USB	727
	WH12-BUUCRUDK	rear Campagnolo FW body - USB	863
	WH12-BUUCRXUDK	rear HG type FW body - USB	902

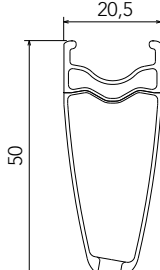
RIM		
	FRONT RIM REAR RIM LABEL KIT VALVE HOLE VALVE EXTENSION DIAMETER TYRE	WH-003BUU (no labels) WH-004BUU (no labels) LAB-BUU12 (front+rear) - LAB-BUU12DK (front+rear DARK) 6,5 mm UT-WH130M (male extension) - UT-WH130F (female extension) 700C (622 x 15C) See section table and inflation pressures on page 205

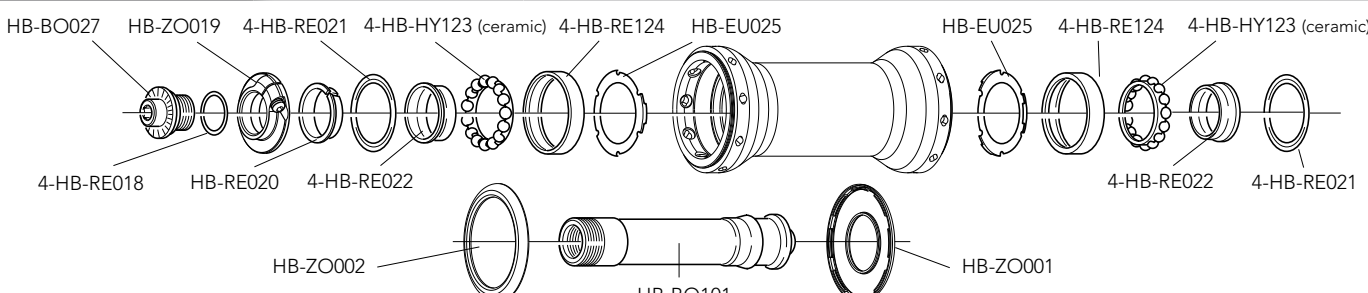
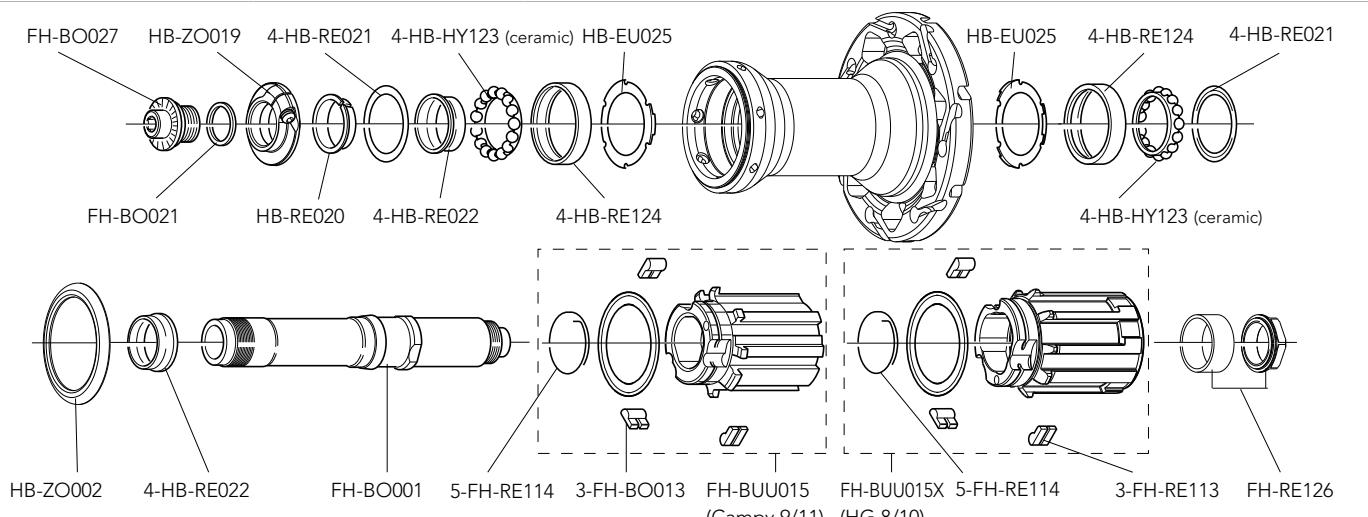
HUBS		
		
		
QUICK-RELEASES	QR12-BUUBFR	front + rear

SPOKES		
COMPLETE FRONT KIT	KIT-03BUU	18 front spokes + 18 nuts + 18 nut supporting plates
COMPLETE REAR KIT	KIT-04BUU	14 rear right spokes + 7 rear left spokes + 21 nuts + 21 nut supporting plates
MINI-KIT	KIT-500BUU	2 front spokes + 2 rear right spokes + 2 rear left spokes + 6 nuts + 6 nut supporting plates
NIPPLES	WH-015BUU	red - 10 pieces
SPOKE RING	UT-WH010	anti-rotation spokes
INSERT NIPPLE	UT-WH160	magnet-attractor for nipple
NIPPLE MAGNET	UT-WH050	nipple-guide
SPOKE SPANNER	UT-WH090	spoke wrenches

NOTES

BULLET™ ULTRA clincher (H50 - CULT™ bearings)

HIGH PROFILE

INTENDED USE	WHEEL CODES	DESCRIPTION	WEIGHT	
This product has been designed and manufactured to be fitted and used only on "racing" or "cyclocross" bikes (if they bear the CX mark), and any other use is expressly excluded. Any other use of this product (like, for instance, cross country, all mountain-enduro, acrobatic off-road, downhill, fourcross, freeride, free-style or any other type of extreme off-road cycling as defined by UCI) can cause accidents, injuries and even death and is therefore expressly forbidden	WH12-BUUCFRC	FRONT+REAR Campagnolo FW body - CULT	1.590	
	WH12-BUUCFRXC	FRONT+REAR HG type FW body - CULT	1.629	
	WH12-BUUCFC	front - CULT	727	
	WH12-BUUCRC	rear Campagnolo FW body - CULT	863	
	WH12-BUUCRXC	rear HG type FW body - CULT	902	
	DARK LABEL			
	WH12-BUUCFRCDK	FRONT+REAR Campagnolo FW body - CULT	1.590	
	WH12-BUUCFRXCDK	FRONT+REAR HG type FW body - CULT	1.629	
	WH12-BUUCFCDK	front - CULT	727	
	WH12-BUUCRCDK	rear Campagnolo FW body - CULT	863	
WH12-BUUCRXCDK	rear HG type FW body - CULT	902		

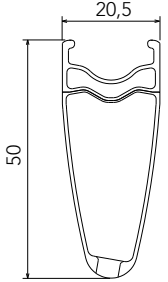
RIM	
 <p>FRONT RIM REAR RIM LABEL KIT VALVE HOLE VALVE EXTENSION DIAMETER TYRE</p>	<p>WH-003BUU (no labels) WH-004BUU (no labels) LAB-BUU12 (front+rear) - LAB-BUU12DK (front+rear DARK) 6,5 mm UT-WH130M (male extension) - UT-WH130F (female extension) 700C (622 x 15C) See section table and inflation pressures on page 205</p>

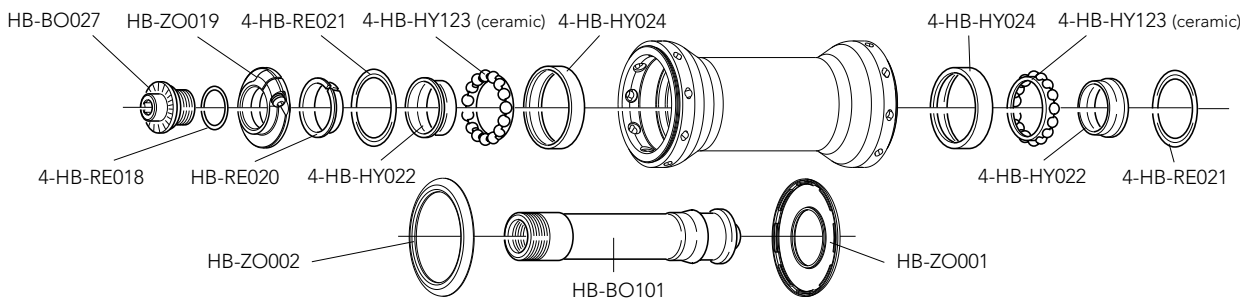
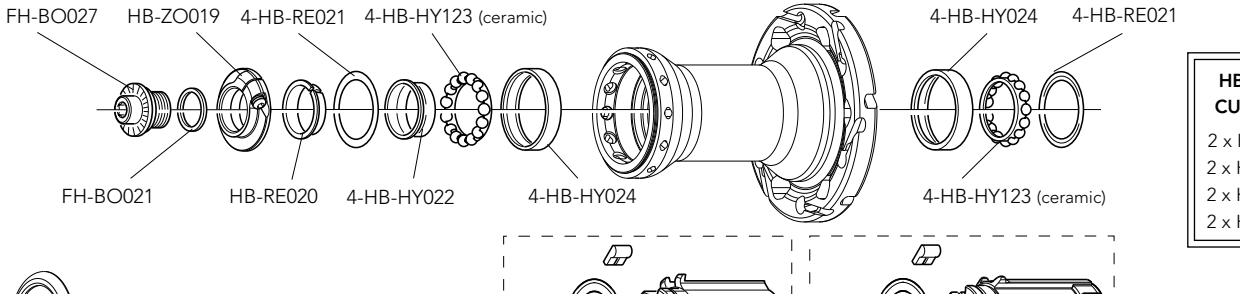
HUBS	
 <p>HB-BO027 HB-ZO019 4-HB-RE021 4-HB-HY123 (ceramic) 4-HB-HY024 4-HB-RE018 HB-RE020 4-HB-HY022 HB-ZO002 HB-BO101 HB-ZO001</p>	 <p>FH-BO027 HB-ZO019 4-HB-RE021 4-HB-HY123 (ceramic) 4-HB-HY024 4-HB-RE021 FH-BO021 HB-RE020 4-HB-HY022 4-HB-HY024 4-HB-HY123 (ceramic)</p> <div style="border: 1px solid black; padding: 5px; width: fit-content;"> <p>HB-HY100 CULT™ KIT 2 x HB-RE021 2 x HB-HY022 2 x HB-HY024 2 x HB-HY123</p> </div> <p>HB-ZO002 4-HB-HY022 FH-BO001 5-FH-RE114 3-FH-BO013 FH-BUU015 FH-BUU015X 5-FH-RE114 3-FH-RE113 FH-RE126 (Campy 9/11) (HG 8/10)</p>

QUICK-RELEASES	QR12-BUUBFR	front + rear
----------------	-------------	--------------

SPOKES		
COMPLETE FRONT KIT	KIT-03BUU	18 front spokes + 18 nuts + 18 nut supporting plates
COMPLETE REAR KIT	KIT-04BUU	14 rear right spokes + 7 rear left spokes + 21 nuts + 21 nut supporting plates
MINI-KIT	KIT-500BUU	2 front spokes + 2 rear right spokes + 2 rear left spokes + 6 nuts + 6 nut supporting plates
NIPPLES	WH-015BUU	red - 10 pieces
SPOKE RING	UT-WH010	anti-rotation spokes
INSERT NIPPLE	UT-WH160	magnet-attractor for nipple
NIPPLE MAGNET	UT-WH050	nipple-guide
SPOKE SPANNER	UT-WH090	spoke wrenches

NOTES

BULLET™ ULTRA clincher (H80 - standard bearings)

HIGH PROFILE

INTENDED USE	WHEEL CODES	DESCRIPTION	WEIGHT	
This product has been designed and manufactured to be fitted and used only on "racing" or "cyclocross" bikes (if they bear the CX mark), and any other use is expressly excluded. Any other use of this product (like, for instance, cross country, all mountain-enduro, acrobatic off-road, downhill, fourcross, freeride, free-style or any other type of extreme off-road cycling as defined by UCI) can cause accidents, injuries and even death and is therefore expressly forbidden	WH12-BUUCFR80	FRONT+REAR Campagnolo FW body	1.770	
	WH12-BUUCFRX80	FRONT+REAR HG type FW body	1.809	
	WH12-BUUCF80	front	815	
	WH12-BUUCR80	rear Campagnolo FW body	955	
	WH12-BUUCRX80	rear HG type FW body	994	
	DARK LABEL			
	WH12-BUUCFR80DK	FRONT+REAR Campagnolo FW body	1.770	
	WH12-BUUCFRX80DK	FRONT+REAR HG type FW body	1.809	
	WH12-BUUCF80DK	front	815	
	WH12-BUUCR80DK	rear Campagnolo FW body	955	
WH12-BUUCR80XDK	rear HG type FW body	994		

RIM AND SPOKES

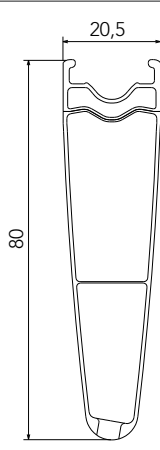

FRONT RIM
 REAR RIM
 LABEL KIT
 VALVE HOLE
 VALVE EXTENSION
 DIAMETER
 TYRE

COMPLETE FRONT KIT
 COMPLETE REAR KIT
 MINI-KIT

NIPPLES
 SPOKE RING
 INSERT NIPPLE
 NIPPLE MAGNET
 SPOKE SPANNER

WH-003BUU80 (no labels)
 WH-004BUU80 (no labels)
 LAB-BUU1280 (front+rear) - LAB-BUU1280DK (front+rear DARK)
 6,5 mm
 UT-WH140M (male extension) - UT-WH140F (female extension)
 700C (622 x 15C)
 See section table and inflation pressures on page 205

KIT-03BUU80 (16 front spokes + 16 nuts + 16 nut supporting plates)
 KIT-04BUU80 (12 rear right spokes+6 rear left spokes+18 nuts+18 nut supporting plates)
 KIT-500BUU80 (2 front spokes+2 rear right spokes+2 rear left spokes+6 nuts+6 nut supporting plates)
 WH-015BUU (red - 10 pieces)
 UT-WH010 (anti-rotation spokes)
 UT-WH160 (magnet-attractor for nipple)
 UT-WH050 (nipple-guide)
 UT-WH090 (spoke wrenches)

HUBS

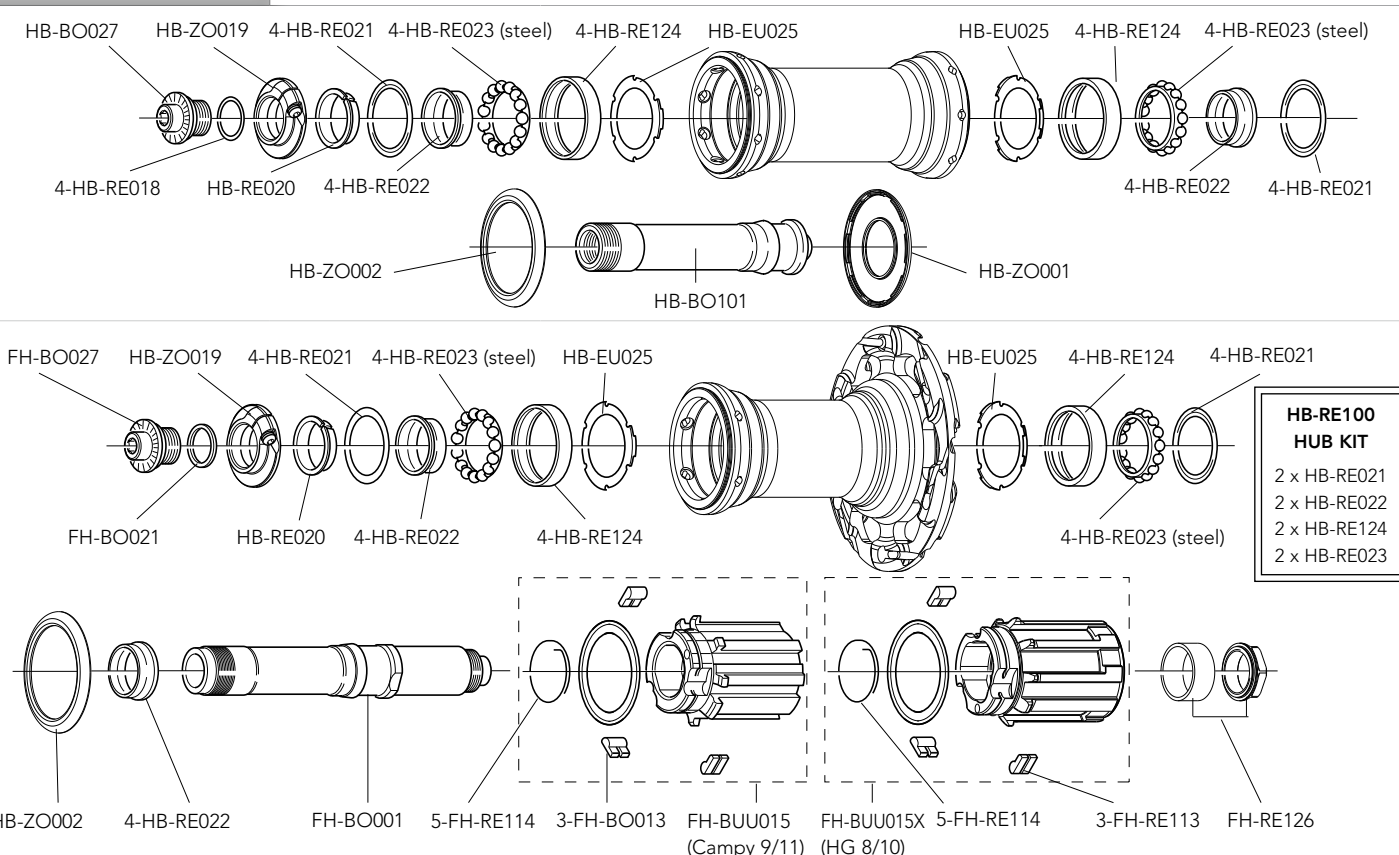

HB-BO027 HB-ZO019 4-HB-RE021 4-HB-RE023 (steel) 4-HB-RE124 HB-EU025 HB-EU025 4-HB-RE124 4-HB-RE023 (steel)

4-HB-RE018 HB-RE020 4-HB-RE022 4-HB-RE022 4-HB-RE021

HB-ZO002 HB-BO101 HB-ZO001

FH-BO027 HB-ZO019 4-HB-RE021 4-HB-RE023 (steel) HB-EU025 HB-EU025 4-HB-RE124 4-HB-RE021

FH-BO021 HB-RE020 4-HB-RE022 4-HB-RE124 4-HB-RE023 (steel)

HB-RE100 HUB KIT
 2 x HB-RE021
 2 x HB-RE022
 2 x HB-RE124
 2 x HB-RE023

HB-ZO002 4-HB-RE022 FH-BO001 5-FH-RE114 3-FH-BO013 FH-BUU015 FH-BUU015X 5-FH-RE114 3-FH-RE113 FH-RE126
 (Campy 9/11) (HG 8/10)

QUICK-RELEASES QR12-BUUBFR front + rear

NOTES

BULLET™ ULTRA clincher (H80 - USB™ bearings)

HIGH PROFILE

INTENDED USE	WHEEL CODES	DESCRIPTION	WEIGHT	
This product has been designed and manufactured to be fitted and used only on "racing" or "cyclocross" bikes (if they bear the CX mark), and any other use is expressly excluded. Any other use of this product (like, for instance, cross country, all mountain-enduro, acrobatic off-road, downhill, fourcross, freeride, free-style or any other type of extreme off-road cycling as defined by UCI) can cause accidents, injuries and even death and is therefore expressly forbidden	WH12-BUUCFRU80	FRONT+REAR Campagnolo FW body - USB	1.770	
	WH12-BUUCFRXU80	FRONT+REAR HG type FW body - USB	1.809	
	WH12-BUUCFU80	front - USB	815	
	WH12-BUUCRU80	rear Campagnolo FW body - USB	955	
	WH12-BUUCRXU80	rear HG type FW body - USB	994	
	DARK LABEL			
	WH12-BUUCFRU80DK	FRONT+REAR Campagnolo FW body - USB	1.770	
	WH12-BUUCFRXU80DK	FRONT+REAR HG type FW body - USB	1.809	
	WH12-BUUCFU80DK	front - USB	815	
	WH12-BUUCRU80DK	rear Campagnolo FW body - USB	955	
WH12-BUUCRXU80DK	rear HG type FW body - USB	994		

RIM AND SPOKES	
	<p>FRONT RIM REAR RIM LABEL KIT VALVE HOLE VALVE EXTENSION DIAMETER TYRE</p> <p>COMPLETE FRONT KIT COMPLETE REAR KIT MINI-KIT NIPPLES SPOKE RING INSERT NIPPLE NIPPLE MAGNET SPOKE SPANNER</p>
	<p>WH-003BUU80 (no labels) WH-004BUU80 (no labels) LAB-BUU1280 (front+rear) - LAB-BUU1280DK (front+rear DARK) 6,5 mm UT-WH140M (male extension) - UT-WH140F (female extension) 700C (622 x 15C) See section table and inflation pressures on page 205</p> <p>KIT-03BUU80 (16 front spokes + 16 nuts + 16 nut supporting plates) KIT-04BUU80 (12 rear right spokes+6 rear left spokes+18 nuts+18 nut supporting plates) KIT-500BUU80 (2 front spokes + 2 rear right spokes + 2 rear left spokes + 6 nuts + 6 nut supporting plates) WH-015BUU (red - 10 pieces) UT-WH010 (anti-rotation spokes) UT-WH160 (magnet-attractor for nipple) UT-WH050 (nipple-guide) UT-WH090 (spoke wrenches)</p>

HUBS	
	<p>HB-BO027 HB-ZO019 4-HB-RE021 4-HB-HY123 (ceramic) 4-HB-RE124 HB-EU025 HB-EU025 4-HB-RE124 4-HB-HY123 (ceramic)</p> <p>4-HB-RE018 HB-RE020 4-HB-RE022 4-HB-RE022 4-HB-RE022 4-HB-RE022 4-HB-RE021</p> <p>HB-ZO002 HB-BO101 HB-ZO001</p>
	<p>FH-BO027 HB-ZO019 4-HB-RE021 4-HB-HY123 (ceramic) HB-EU025 HB-EU025 4-HB-RE124 4-HB-RE021</p> <p>FH-BO021 HB-RE020 4-HB-RE022 4-HB-RE124 4-HB-HY123 (ceramic)</p> <p>HB-ZO002 4-HB-RE022 FH-BO001 5-FH-RE114 3-FH-BO013 FH-BUU015 FH-BUU015X 5-FH-RE114 3-FH-RE113 FH-RE126</p> <p>(Campy 9/11) (HG 8/10)</p>
QUICK-RELEASES	QR12-BUUBFR front + rear

NOTES

BULLET™ ULTRA clincher (H80 - CULT™ bearings)

HIGH PROFILE

INTENDED USE	WHEEL CODES	DESCRIPTION	WEIGHT
This product has been designed and manufactured to be fitted and used only on "racing" or "cyclocross" bikes (if they bear the CX mark), and any other use is expressly excluded. Any other use of this product (like, for instance, cross country, all mountain-enduro, acrobatic off-road, downhill, fourcross, freeride, free-style or any other type of extreme off-road cycling as defined by UCI) can cause accidents, injuries and even death and is therefore expressly forbidden	WH12-BUUCFRC80	FRONT+REAR Campagnolo FW body - CULT	1.770
	WH12-BUUCFRXC80	FRONT+REAR HG type FW body - CULT	1.809
	WH12-BUUCFC80	front - CULT	815
	WH12-BUUCRC80	rear Campagnolo FW body - CULT	955
	WH12-BUUCRXC80	rear HG type FW body - CULT	994
	DARK LABEL		
	WH12-BUUCFRC80DK	FRONT+REAR Campagnolo FW body - CULT	1.770
	WH12-BUUCFRXC80DK	FRONT+REAR HG type FW body - CULT	1.809
	WH12-BUUCFC80DK	front - CULT	815
	WH12-BUUCRC80DK	rear Campagnolo FW body - CULT	955
	WH12-BUUCRXC80DK	rear HG type FW body - CULT	994

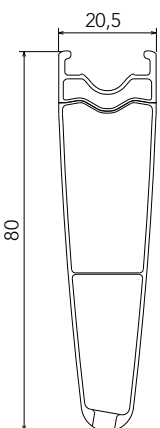
RIM AND SPOKES	
	<p>FRONT RIM REAR RIM LABEL KIT VALVE HOLE VALVE EXTENSION DIAMETER TYRE</p> <p>COMPLETE FRONT KIT COMPLETE REAR KIT MINI-KIT</p> <p>NIPPLES SPOKE RING INSERT NIPPLE NIPPLE MAGNET SPOKE SPANNER</p>
<p>WH-003BUU80 (no labels) WH-004BUU80 (no labels) LAB-BUU1280 (front+rear) - LAB-BUU1280DK (front+rear DARK) 6,5 mm UT-WH140M (male extension) - UT-WH140F (female extension) 700C (622 x 15C) See section table and inflation pressures on page 205</p>	<p>KIT-03BUU80 (16 front spokes + 16 nuts + 16 nut supporting plates) KIT-04BUU80 (12 rear right spokes+6 rear left spokes+18 nuts+18 nut supporting plates) KIT-500BUU80 (2 front spokes + 2 rear right spokes + 2 rear left spokes + 6 nuts + 6 nut supporting plates) WH-015BUU (red - 10 pieces) UT-WH010 (anti-rotation spokes) UT-WH160 (magnet-attractor for nipple) UT-WH050 (nipple-guide) UT-WH090 (spoke wrenches)</p>

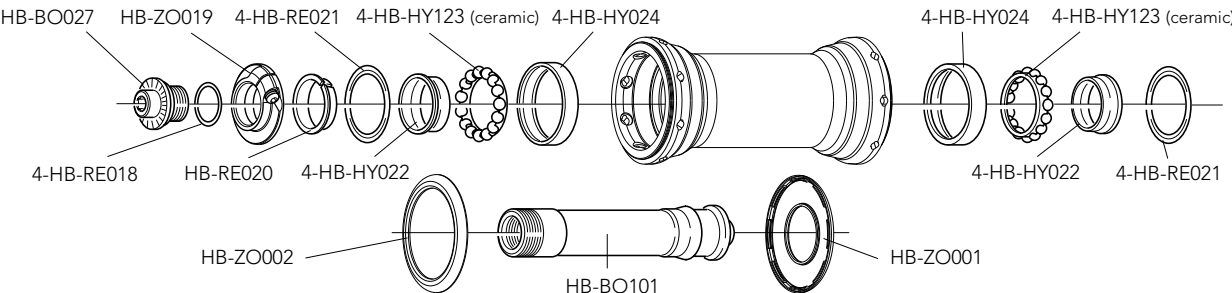
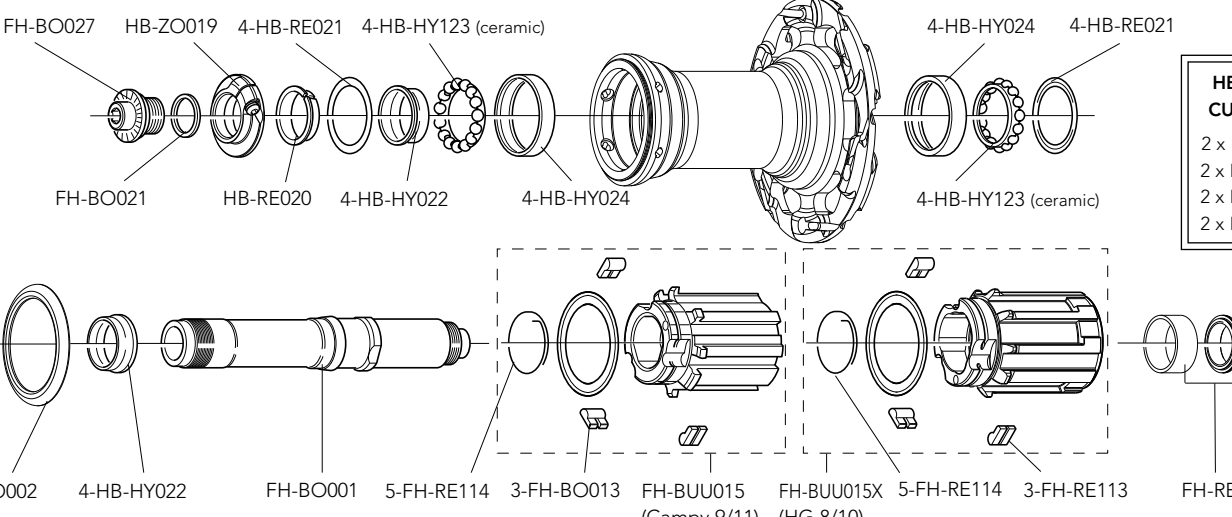
HUBS	
	
	<div style="border: 1px solid black; padding: 5px; width: fit-content;"> <p>HB-HY100 CULT™ KIT</p> <p>2 x HB-RE021 2 x HB-HY022 2 x HB-HY024 2 x HB-HY123</p> </div>
<p>QUICK-RELEASES</p>	<p>QR12-BUUBFR</p> <p>front + rear</p>

NOTES

BULLET™ ULTRA clincher (H105 - standard bearings)

HIGH PROFILE

INTENDED USE	WHEEL CODES	DESCRIPTION	WEIGHT	
This product has been designed and manufactured to be fitted and used only on "racing" or "cyclocross" bikes (if they bear the CX mark), and any other use is expressly excluded. Any other use of this product (like, for instance, cross country, all mountain-enduro, acrobatic off-road, downhill, fourcross, freeride, free-style or any other type of extreme off-road cycling as defined by UCI) can cause accidents, injuries and even death and is therefore expressly forbidden	WH12-BUUCFR105	FRONT+REAR Campagnolo FW body	1.960	
	WH12-BUUCFRX105	FRONT+REAR HG type FW body	1.999	
	WH12-BUUCF105	front	910	
	WH12-BUUCR105	rear Campagnolo FW body	1.050	
	WH12-BUUCRX105	rear HG type FW body	1.089	
	DARK LABEL			
	WH12-BUUCFR105DK	FRONT+REAR Campagnolo FW body	1.960	
	WH12-BUUCFRX105DK	FRONT+REAR HG type FW body	1.999	
	WH12-BUUCF105DK	front	910	
	WH12-BUUCR105DK	rear Campagnolo FW body	1.050	
WH12-BUUCR105XDK	rear HG type FW body	1.089		

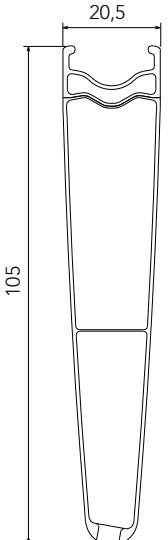
RIM AND SPOKES	
	<p>FRONT RIM REAR RIM LABEL KIT VALVE HOLE VALVE EXTENSION DIAMETER TYRE</p> <p>COMPLETE FRONT KIT COMPLETE REAR KIT MINI-KIT</p> <p>NIPPLES SPOKE RING INSERT NIPPLE NIPPLE MAGNET SPOKE SPANNER</p>
	<p>WH-003BUU105 (no labels) WH-004BUU105 (no labels) LAB-BUU12105 (front+rear) - LAB-BUU12105DK (front+rear DARK) 6,5 mm UT-WH150M (male extension) - UT-WH150F (female extension) 700C (622 x 15C) See section table and inflation pressures on page 205</p> <p>KIT-03BUU105 (16 front spokes + 16 nuts + 16 nut supporting plates) KIT-04BUU105 (12 rear right spokes+6 rear left spokes+18 nuts+18 nut supporting plates) KIT-500BUU105 (2 front spokes + 2 rear right spokes + 2 rear left spokes + 6 nuts + 6 nut supporting plates) WH-015BUU (red - 10 pieces) UT-WH010 (anti-rotation spokes) UT-WH160 (magnet-attractor for nipple) UT-WH050 (nipple-guide) UT-WH090 (spoke wrenches)</p>

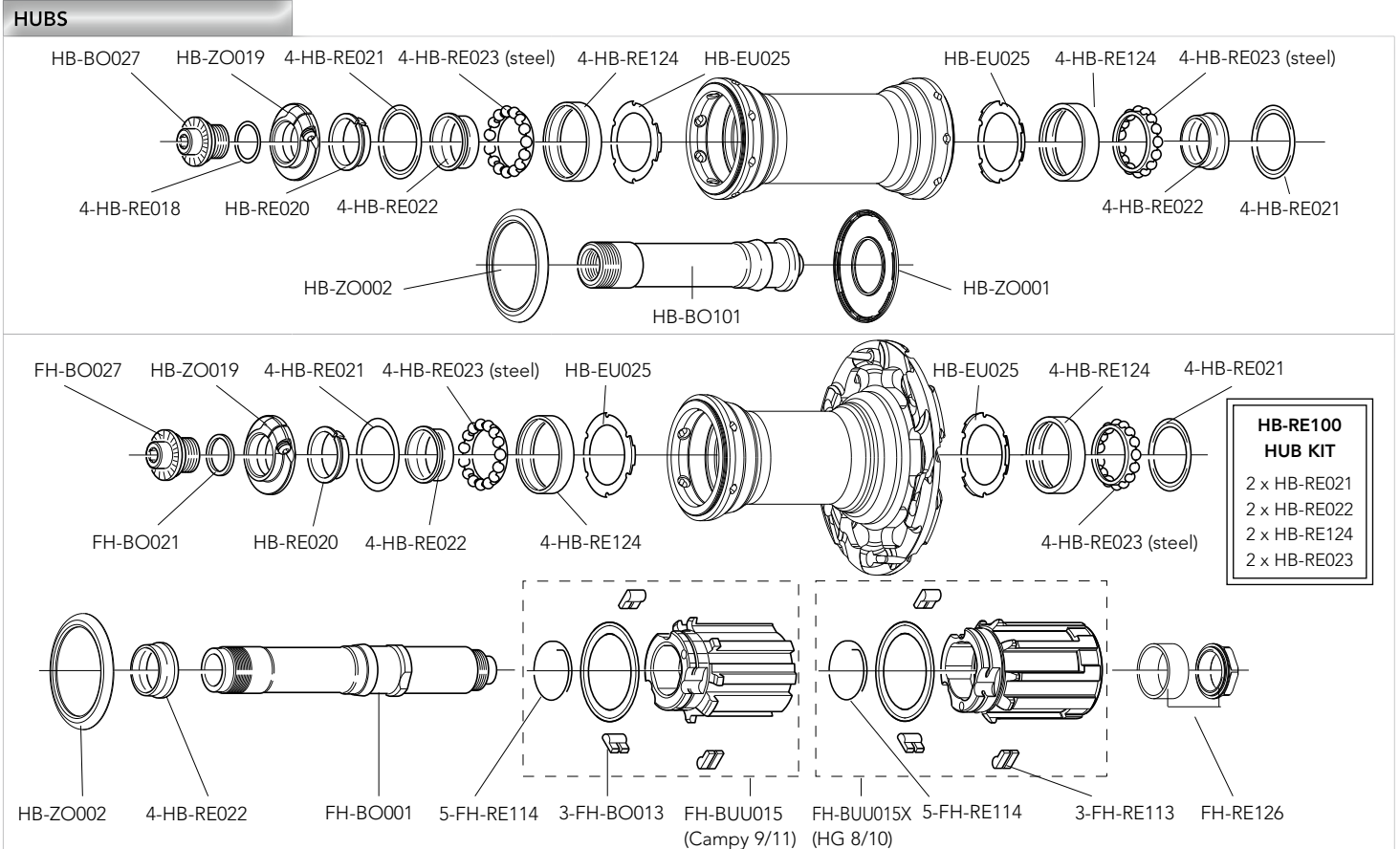

QUICK-RELEASES	QR12-BUUBFR	front + rear
----------------	-------------	--------------

NOTES

BULLET™ ULTRA clincher (H105 - USB™ bearings)

HIGH PROFILE

INTENDED USE	WHEEL CODES	DESCRIPTION	WEIGHT
This product has been designed and manufactured to be fitted and used only on "racing" or "cyclocross" bikes (if they bear the CX mark), and any other use is expressly excluded. Any other use of this product (like, for instance, cross country, all mountain-enduro, acrobatic off-road, downhill, fourcross, freeride, free-style or any other type of extreme off-road cycling as defined by UCI) can cause accidents, injuries and even death and is therefore expressly forbidden	WH12-BUUCFRU105	FRONT+REAR Campagnolo FW body - USB	1.960
	WH12-BUUCFRXU105	FRONT+REAR HG type FW body - USB	1.999
	WH12-BUUCFU105	front - USB	910
	WH12-BUUCRU105	rear Campagnolo FW body - USB	1.050
	WH12-BUUCRXU105	rear HG type FW body - USB	1.089
	DARK LABEL		
WH12-BUUCFRU105DK	FRONT+REAR Campagnolo FW body - USB	1.960	
WH12-BUUCFRXU105DK	FRONT+REAR HG type FW body - USB	1.999	
WH12-BUUCFU105DK	front - USB	910	
WH12-BUUCRU105DK	rear Campagnolo FW body - USB	1.050	
WH12-BUUCRXU105DK	rear HG type FW body - USB	1.089	

RIM AND SPOKES

FRONT RIM
 REAR RIM
 LABEL KIT
 VALVE HOLE
 VALVE EXTENSION
 DIAMETER
 TYRE

COMPLETE FRONT KIT
 COMPLETE REAR KIT
 MINI-KIT

NIPPLES
 SPOKE RING
 INSERT NIPPLE
 NIPPLE MAGNET
 SPOKE SPANNER

WH-003BUU105 (no labels)
 WH-004BUU105 (no labels)
 LAB-BUU12105 (front+rear) - LAB-BUU12105DK (front+rear DARK)
 6,5 mm
 UT-WH150M (male extension) - UT-WH150F (female extension)
 700C (622 x 15C)
 See section table and inflation pressures on page 205

KIT-03BUU105 (16 front spokes + 16 nuts + 16 nut supporting plates)
 KIT-04BUU105 (12 rear right spokes+6 rear left spokes+18 nuts+18 nut supporting plates)
 KIT-500BUU105 (2 front spokes + 2 rear right spokes + 2 rear left spokes + 6 nuts + 6 nut supporting plates)

WH-015BUU (red - 10 pieces)
 UT-WH010 (anti-rotation spokes)
 UT-WH160 (magnet-attractor for nipple)
 UT-WH050 (nipple-guide)
 UT-WH090 (spoke wrenches)

HUBS

HB-BO027 HB-ZO019 4-HB-RE021 4-HB-HY123 (ceramic) 4-HB-RE124 HB-EU025 HB-EU025 4-HB-RE124 4-HB-HY123 (ceramic)
 4-HB-RE018 HB-RE020 4-HB-RE022 4-HB-RE022 4-HB-RE021
 HB-ZO002 HB-BO101 HB-ZO001

FH-BO027 HB-ZO019 4-HB-RE021 4-HB-HY123 (ceramic) HB-EU025 HB-EU025 4-HB-RE124 4-HB-RE021
 FH-BO021 HB-RE020 4-HB-RE022 4-HB-RE124 4-HB-HY123 (ceramic)

HB-ZO002 4-HB-RE022 FH-BO001 5-FH-RE114 3-FH-BO013 FH-BUU015 FH-BUU015X 5-FH-RE114 3-FH-RE113 FH-RE126
 (Campy 9/11) (HG 8/10)

QUICK-RELEASES	QR12-BUUBFR	front + rear
----------------	-------------	--------------

NOTES

BULLET™ ULTRA clincher (H105 - CULT™ bearings)

HIGH PROFILE

INTENDED USE	WHEEL CODES	DESCRIPTION	WEIGHT	
This product has been designed and manufactured to be fitted and used only on "racing" or "cyclocross" bikes (if they bear the CX mark), and any other use is expressly excluded. Any other use of this product (like, for instance, cross country, all mountain-enduro, acrobatic off-road, downhill, fourcross, freeride, free-style or any other type of extreme off-road cycling as defined by UCI) can cause accidents, injuries and even death and is therefore expressly forbidden	WH12-BUUCFRC105	FRONT+REAR Campagnolo FW body - CULT	1.960	
	WH12-BUUCFRXC105	FRONT+REAR HG type FW body - CULT	1.999	
	WH12-BUUCFC105	front - CULT	910	
	WH12-BUUCRC105	rear Campagnolo FW body - CULT	1.050	
	WH12-BUUCRXC105	rear HG type FW body - CULT	1.089	
	DARK LABEL			
	WH12-BUUCFRC105DK	FRONT+REAR Campagnolo FW body - CULT	1.960	
	WH12-BUUCFRXC105DK	FRONT+REAR HG type FW body - CULT	1.999	
	WH12-BUUCFC105DK	front - CULT	910	
	WH12-BUUCRC105DK	rear Campagnolo FW body - CULT	1.050	
WH12-BUUCRXC105DK	rear HG type FW body - CULT	1.089		

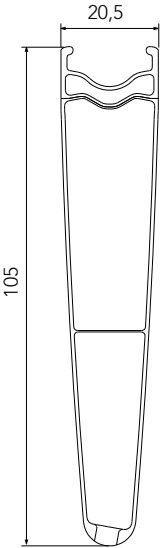
RIM AND SPOKES	
	<p>FRONT RIM REAR RIM LABEL KIT VALVE HOLE VALVE EXTENSION DIAMETER TYRE</p> <p>COMPLETE FRONT KIT COMPLETE REAR KIT MINI-KIT</p> <p>NIPPLES SPOKE RING INSERT NIPPLE NIPPLE MAGNET SPOKE SPANNER</p>
<p>WH-003BUU105 (no labels) WH-004BUU105 (no labels) LAB-BUU12105 (front+rear) - LAB-BUU12105DK (front+rear DARK) 6,5 mm UT-WH150M (male extension) - UT-WH150F (female extension) 700C (622 x 15C) See section table and inflation pressures on page 205</p>	<p>KIT-03BUU105 (16 front spokes + 16 nuts + 16 nut supporting plates) KIT-04BUU105 (12 rear right spokes+6 rear left spokes+18 nuts+18 nut supporting plates) KIT-500BUU105 (2 front spokes + 2 rear right spokes + 2 rear left spokes + 6 nuts + 6 nut supporting plates) WH-015BUU (red - 10 pieces) UT-WH010 (anti-rotation spokes) UT-WH160 (magnet-attractor for nipple) UT-WH050 (nipple-guide) UT-WH090 (spoke wrenches)</p>

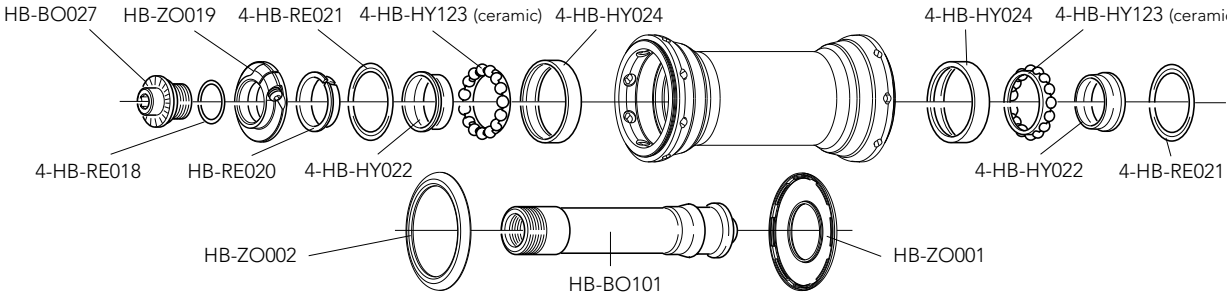
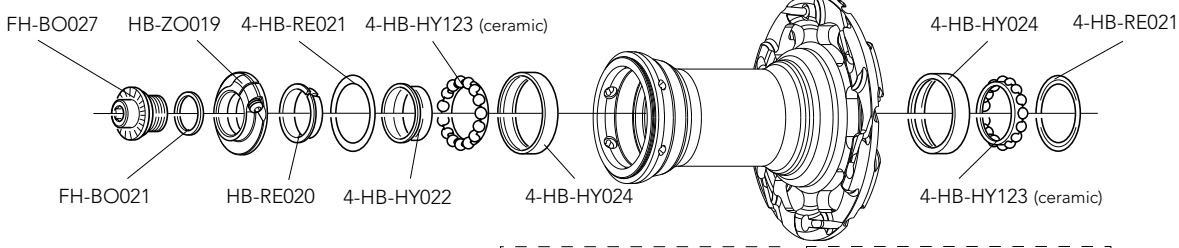
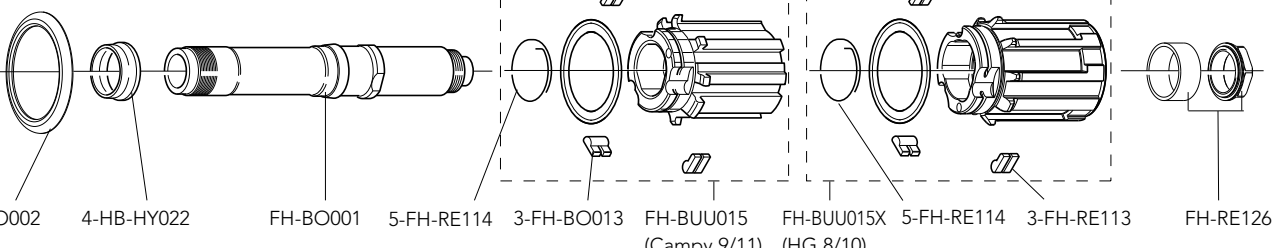
HUBS	
	
	<div style="border: 1px solid black; padding: 5px;"> <p>HB-HY100 CULT™ KIT</p> <p>2 x HB-RE021 2 x HB-HY022 2 x HB-HY024 2 x HB-HY123</p> </div>
	

QUICK-RELEASES	QR12-BUUBFR	front + rear
----------------	-------------	--------------

NOTES

BULLET™ ULTRA 2-Way Fit™ (H50 - standard bearings)

HIGH PROFILE

INTENDED USE	WHEEL CODES	DESCRIPTION	WEIGHT	
This product has been designed and manufactured to be fitted and used only on "racing" or "cyclocross" bikes (if they bear the CX mark), and any other use is expressly excluded. Any other use of this product (like, for instance, cross country, all mountain-enduro, acrobatic off-road, downhill, fourcross, freeride, free-style or any other type of extreme off-road cycling as defined by UCI) can cause accidents, injuries and even death and is therefore expressly forbidden	WH12-BUU2FR	FRONT+REAR Campagnolo FW body	1.590	
	WH12-BUU2FRX	FRONT+REAR HG type FW body	1.629	
	WH12-BUU2F	front	727	
	WH12-BUU2R	rear Campagnolo FW body	863	
	WH12-BUU2RX	rear HG type FW body	902	
	DARK LABEL			
	WH12-BUU2FRDK	FRONT+REAR Campagnolo FW body	1.590	
	WH12-BUU2FRXDK	FRONT+REAR HG type FW body	1.629	
	WH12-BUU2FDK	front	727	
	WH12-BUU2RDK	rear Campagnolo FW body	863	
WH12-BUU2RXDK	rear HG type FW body	902		

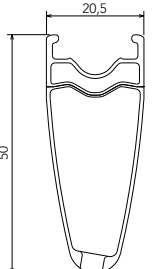
RIM		
	FRONT RIM REAR RIM LABEL KIT VALVE HOLE 2-WAY FIT™ VALVE VALVE HOLE BUSHING VALVE EXTENSION DIAMETER TYRE	WH-013BUU (no labels) WH-014BUU (no labels) LAB-BUU12 (front+rear) - LAB-BUU12DK (front+rear DARK) 6,5 mm WH-SH001 5-WH-SH002 (for valve seat reduction - 5 pieces) UT-WH100M (male extension) - UT-WH130F (female extension) 634mm See recommended tyre manufacturer inflation pressure

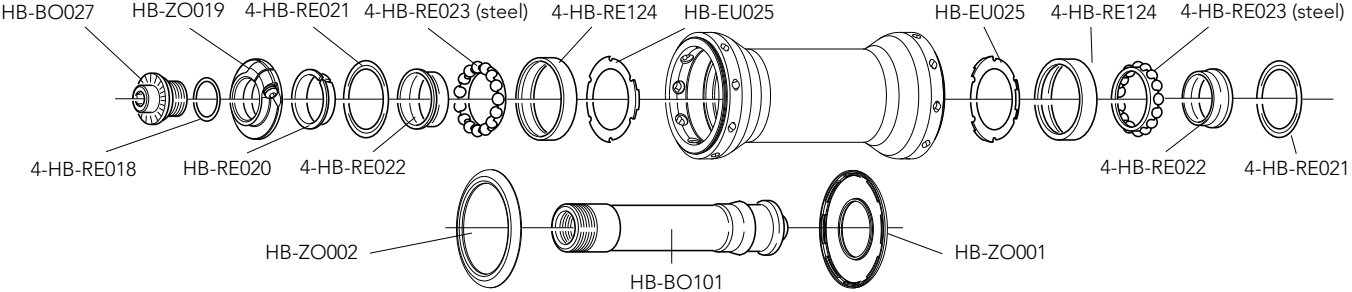
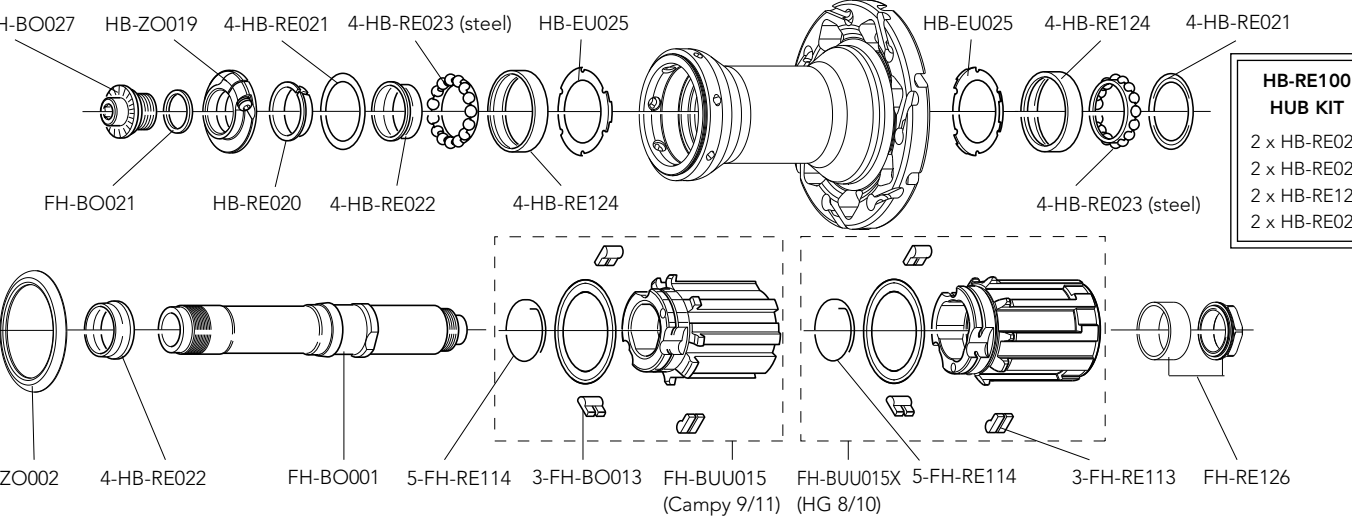
HUBS		
		
	HB-RE100 HUB KIT 2 x HB-RE021 2 x HB-RE022 2 x HB-RE124 2 x HB-RE023	
QUICK-RELEASES	QR12-BUUBFR	front + rear

SPOKES		
COMPLETE FRONT KIT	KIT-03BUU	18 front spokes + 18 nuts + 18 nut supporting plates
COMPLETE REAR KIT	KIT-04BUU	14 rear right spokes + 7 rear left spokes + 21 nuts + 21 nut supporting plates
MINI-KIT	KIT-500BUU	2 front spokes + 2 rear right spokes + 2 rear left spokes + 6 nuts + 6 nut supporting plates
NIPPLES	WH-015BUU	red - 10 pieces
SPOKE RING	UT-WH010	anti-rotation spokes
INSERT NIPPLE	UT-WH160	magnet-attractor for nipple
NIPPLE MAGNET	UT-WH050	nipple-guide
SPOKE SPANNER	UT-WH090	spoke wrenches

NOTES

BULLET™ ULTRA 2-Way Fit™ (H50 - USB™ bearings)

HIGH PROFILE

INTENDED USE	WHEEL CODES	DESCRIPTION	WEIGHT	
This product has been designed and manufactured to be fitted and used only on "racing" or "cyclocross" bikes (if they bear the CX mark), and any other use is expressly excluded. Any other use of this product (like, for instance, cross country, all mountain-enduro, acrobatic off-road, downhill, fourcross, freeride, free-style or any other type of extreme off-road cycling as defined by UCI) can cause accidents, injuries and even death and is therefore expressly forbidden	WH12-BUU2FRU	FRONT+REAR Campagnolo FW body - USB	1.590	
	WH12-BUU2FRXU	FRONT+REAR HG type FW body - USB	1.629	
	WH12-BUU2FU	front - USB	727	
	WH12-BUU2RU	rear Campagnolo FW body - USB	863	
	WH12-BUU2RXU	rear HG type FW body - USB	902	
	DARK LABEL			
	WH12-BUU2FRUDK	FRONT+REAR Campagnolo FW body - USB	1.590	
	WH12-BUU2FRXUDK	FRONT+REAR HG type FW body - USB	1.629	
	WH12-BUU2FUDK	front - USB	727	
	WH12-BUU2RUDK	rear Campagnolo FW body - USB	863	
WH12-BUU2RXUDK	rear HG type FW body - USB	902		

RIM

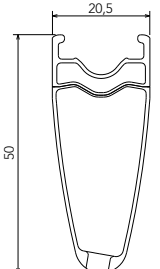
	<p>FRONT RIM REAR RIM LABEL KIT VALVE HOLE VALVE 2-Way Fit™ VALVE HOLE BUSHING VALVE EXTENSION DIAMETER TYRE</p>	<p>WH-013BUU (no labels) WH-014BUU (no labels) LAB-BUU12 (front+rear) - LAB-BUU12DK (front+rear DARK) 6,5 mm WH-SH001 5-WH-SH002 (for valve seat reduction - 5 pieces) UT-WH100M (male extension) - UT-WH130F (female extension) 634mm See recommended tyre manufacturer inflation pressure</p>
-----------------------------------------------------------------------------------	--------------------------------------------------------------------------------------------------------------------------------------------------	---------------------------------------------------------------------------------------------------------------------------------------------------------------------------------------------------------------------------------------------------------------------------------------------------------------------------------

HUBS

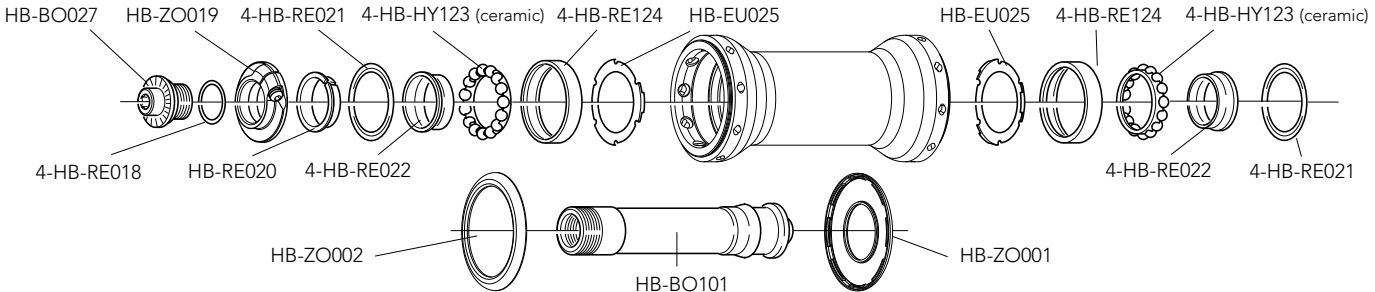
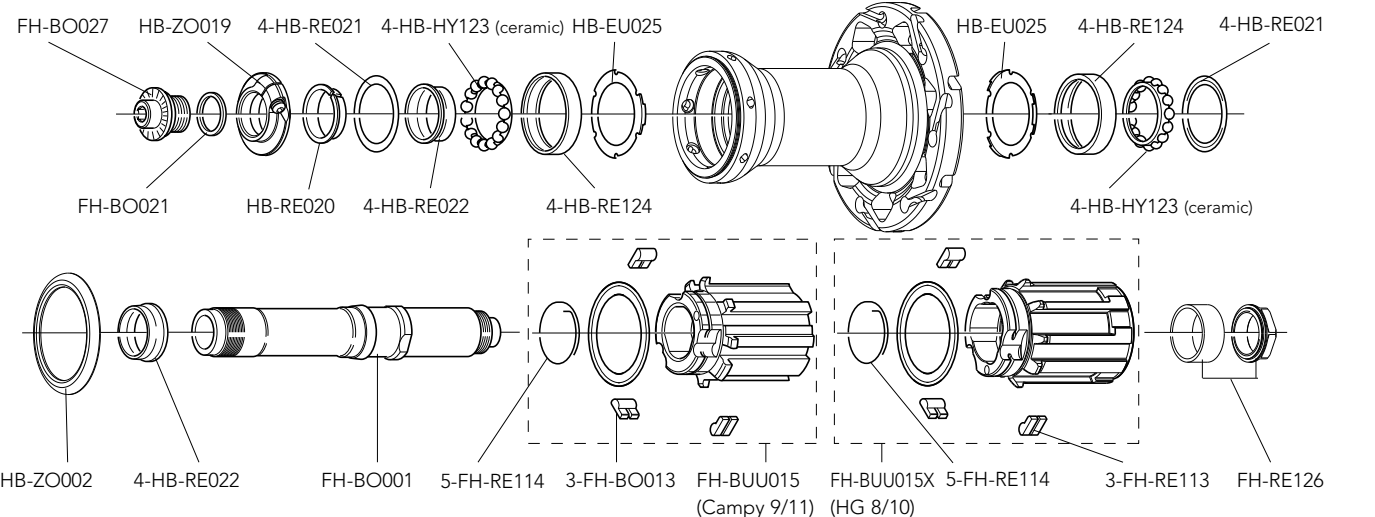
	<p>QUICK-RELEASES</p> <p>QR12-BUUBFR</p> <p>front + rear</p>
 <p>(Campy 9/11) (HG 8/10)</p>	<p>SPOKES</p> <p>COMPLETE FRONT KIT COMPLETE REAR KIT MINI-KIT NIPPLES SPOKE RING INSERT NIPPLE NIPPLE MAGNET SPOKE SPANNER</p> <p>KIT-03BUU KIT-04BUU KIT-500BUU WH-015BUU UT-WH010 UT-WH160 UT-WH050 UT-WH090</p> <p>18 front spokes + 18 nuts + 18 nut supporting plates 14 rear right spokes + 7 rear left spokes + 21 nuts + 21 nut supporting plates 2 front spokes + 2 rear right spokes + 2 rear left spokes + 6 nuts + 6 nut supporting plates red - 10 pieces anti-rotation spokes magnet-attractor for nipple nipple-guide spoke wrenches</p>
<p>NOTES</p>	

BULLET™ ULTRA 2-Way Fit™ (H50 - CULT™ bearings)

HIGH PROFILE

INTENDED USE	WHEEL CODES	DESCRIPTION	WEIGHT	
This product has been designed and manufactured to be fitted and used only on "racing" or "cyclocross" bikes (if they bear the CX mark), and any other use is expressly excluded. Any other use of this product (like, for instance, cross country, all mountain-enduro, acrobatic off-road, downhill, fourcross, freeride, free-style or any other type of extreme off-road cycling as defined by UCI) can cause accidents, injuries and even death and is therefore expressly forbidden	WH12-BUU2FRC	FRONT+REAR Campagnolo FW body - CULT	1.590	
	WH12-BUU2FRXC	FRONT+REAR HG type FW body - CULT	1.629	
	WH12-BUU2FC	front - CULT	727	
	WH12-BUU2RC	rear Campagnolo FW body - CULT	863	
	WH12-BUU2RXC	rear HG type FW body - CULT	902	
	DARK LABEL			
	WH12-BUU2FRCDK	FRONT+REAR Campagnolo FW body - CULT	1.590	
	WH12-BUU2FRXC DK	FRONT+REAR HG type FW body - CULT	1.629	
	WH12-BUU2FC DK	front - CULT	727	
	WH12-BUU2RC DK	rear Campagnolo FW body - CULT	863	
WH12-BUU2RXC DK	rear HG type FW body - CULT	902		

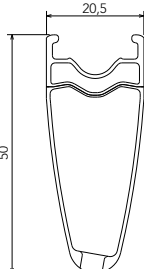
RIM		
	FRONT RIM REAR RIM LABEL KIT VALVE HOLE 2-Way Fit™ VALVE VALVE HOLE BUSHING VALVE EXTENSION DIAMETER TYRE	WH-013BUU (no labels) WH-014BUU (no labels) LAB-BUU12 (front+rear) - LAB-BUU12DK (front+rear DARK) 6,5 mm WH-SH001 5-WH-SH002 (for valve seat reduction - 5 pieces) UT-WH100M (male extension) - UT-WH130F (female extension) 634mm See recommended tyre manufacturer inflation pressure

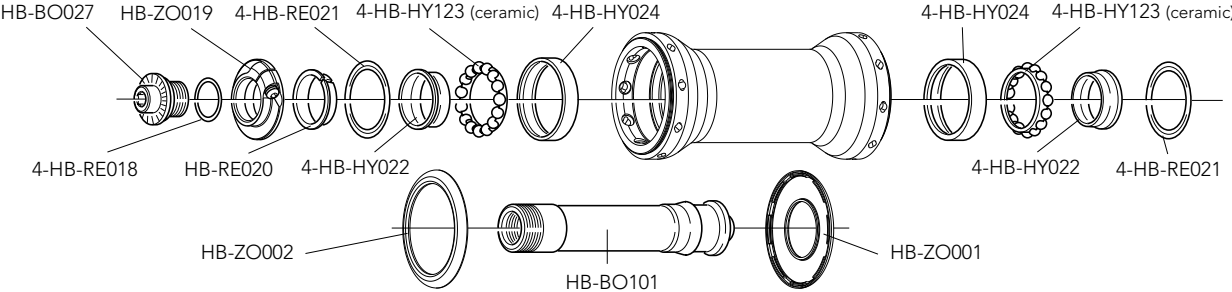
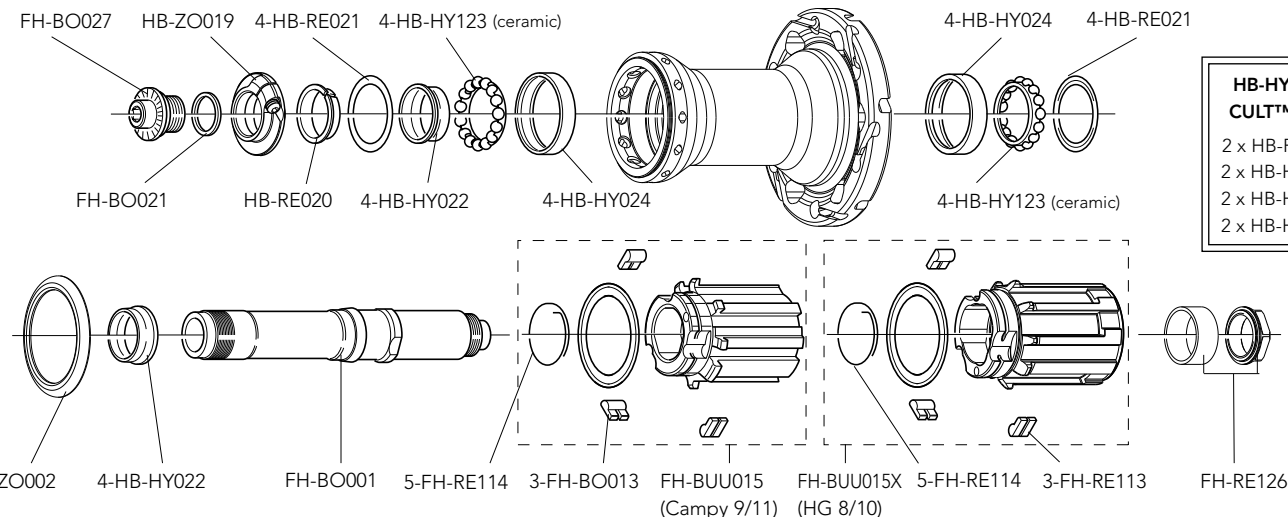
HUBS		
		
 <div style="border: 1px solid black; padding: 5px; width: fit-content; margin-top: 10px;"> HB-HY100 CULT™ KIT 2 x HB-RE021 2 x HB-HY022 2 x HB-HY024 2 x HB-HY123 </div>		
QUICK-RELEASES	QR12-BUUBFR	front + rear

SPOKES		
COMPLETE FRONT KIT	KIT-03BUU	18 front spokes + 18 nuts + 18 nut supporting plates
COMPLETE REAR KIT	KIT-04BUU	14 rear right spokes + 7 rear left spokes + 21 nuts + 21 nut supporting plates
MINI-KIT	KIT-500BUU	2 front spokes + 2 rear right spokes + 2 rear left spokes + 6 nuts + 6 nut supporting plates
NIPPLES	WH-015BUU	red - 10 pieces
SPOKE RING	UT-WH010	anti-rotation spokes
INSERT NIPPLE	UT-WH160	magnet-attractor for nipple
NIPPLE MAGNET	UT-WH050	nipple-guide
SPOKE SPANNER	UT-WH090	spoke wrenches

NOTES

BULLET™ ULTRA 2-Way Fit™ (H80 - standard bearings)

HIGH PROFILE

INTENDED USE	WHEEL CODES	DESCRIPTION	WEIGHT	
This product has been designed and manufactured to be fitted and used only on "racing" or "cyclocross" bikes (if they bear the CX mark), and any other use is expressly excluded. Any other use of this product (like, for instance, cross country, all mountain-enduro, acrobatic off-road, downhill, fourcross, freeride, free-style or any other type of extreme off-road cycling as defined by UCI) can cause accidents, injuries and even death and is therefore expressly forbidden	WH12-BUU2FR80	FRONT+REAR Campagnolo FW body	1.770	
	WH12-BUU2FRX80	FRONT+REAR HG type FW body	1.809	
	WH12-BUU2F80	front	815	
	WH12-BUU2R80	rear Campagnolo FW body	955	
	WH12-BUU2RX80	rear HG type FW body	994	
	DARK LABEL			
	WH12-BUU2FR80DK	FRONT+REAR Campagnolo FW body	1.770	
	WH12-BUU2FRX80DK	FRONT+REAR HG type FW body	1.809	
	WH12-BUU2F80DK	front	815	
	WH12-BUU2R80DK	rear Campagnolo FW body	955	
WH12-BUU2R80XDK	rear HG type FW body	994		

RIM AND SPOKES

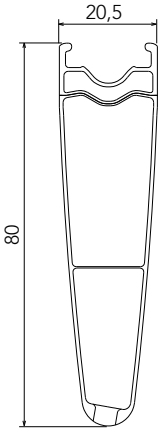

FRONT RIM
 REAR RIM
 LABEL KIT
 VALVE HOLE
 2-Way Fit™ VALVE
 VALVE HOLE BUSHING
 VALVE EXTENSION
 DIAMETER
 TYRE

COMPLETE FRONT KIT
 COMPLETE REAR KIT
 MINI-KIT

NIPPLES
 SPOKE RING
 INSERT NIPPLE
 NIPPLE MAGNET
 SPOKE SPANNER

WH-013BUU80 (no labels)
 WH-014BUU80 (no labels)
 LAB-BUU1280 (front+rear) - LAB-BUU1280DK (front+rear DARK)
 6,5 mm
 WH-SH001
 5-WH-SH002 (for valve seat reduction - 5 pieces)
 UT-WH110M (male extension) - UT-WH140F (female extension)
 634mm
 See recommended tyre manufacturer inflation pressure

KIT-03BUU80 (16 front spokes + 16 nuts + 16 nut supporting plates)
 KIT-04BUU80 (12 rear right spokes+6 rear left spokes+18 nuts+18 nut supporting plates)
 KIT-500BUU80 (2 front spokes+2 rear right spokes+2 rear left spokes+6 nuts+6 nut supporting plates)

WH-015BUU (red - 10 pieces)
 UT-WH010 (anti-rotation spokes)
 UT-WH160 (magnet-attractor for nipple)
 UT-WH050 (nipple-guide)
 UT-WH090 (spoke wrenches)

HUBS

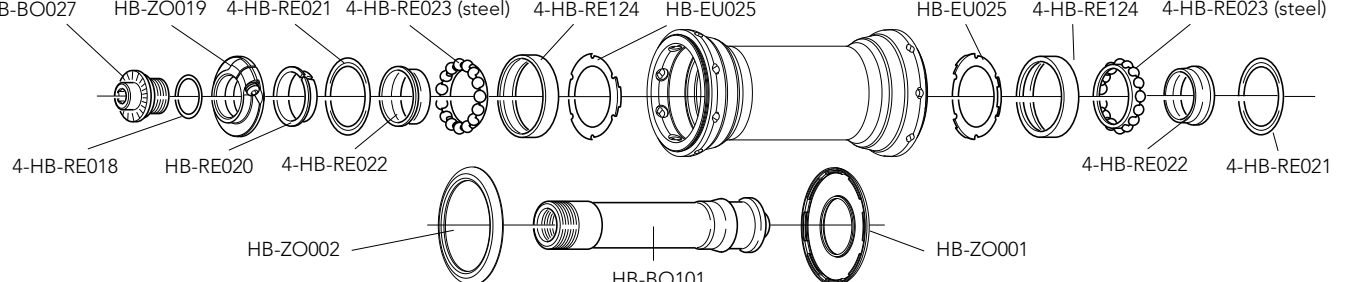
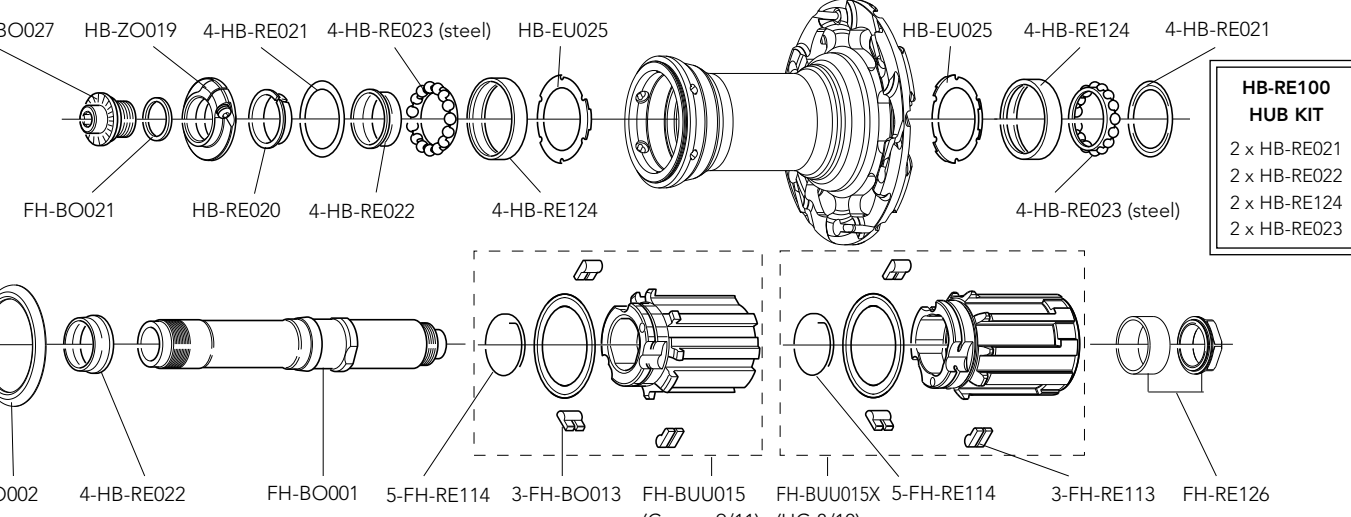
HB-RE100 HUB KIT

2 x HB-RE021
 2 x HB-RE022
 2 x HB-RE124
 2 x HB-RE023

QUICK-RELEASES

QR12-BUUBFR

front + rear

NOTES

BULLET™ ULTRA 2-Way Fit™ (H80 - USB™ bearings)

HIGH PROFILE

INTENDED USE	WHEEL CODES	DESCRIPTION	WEIGHT	
This product has been designed and manufactured to be fitted and used only on "racing" or "cyclocross" bikes (if they bear the CX mark), and any other use is expressly excluded. Any other use of this product (like, for instance, cross country, all mountain-enduro, acrobatic off-road, downhill, fourcross, freeride, free-style or any other type of extreme off-road cycling as defined by UCI) can cause accidents, injuries and even death and is therefore expressly forbidden	WH12-BUU2FRU80	FRONT+REAR Campagnolo FW body - USB	1.770	
	WH12-BUU2FRXU80	FRONT+REAR HG type FW body - USB	1.809	
	WH12-BUU2FU80	front - USB	815	
	WH12-BUU2RU80	rear Campagnolo FW body - USB	955	
	WH12-BUU2RXU80	rear HG type FW body - USB	994	
	DARK LABEL			
	WH12-BUU2FRU80DK	FRONT+REAR Campagnolo FW body - USB	1.770	
	WH12-BUU2FRXU80DK	FRONT+REAR HG type FW body - USB	1.809	
	WH12-BUU2FU80DK	front - USB	815	
	WH12-BUU2RU80DK	rear Campagnolo FW body - USB	955	
WH12-BUU2RXU80DK	rear HG type FW body - USB	994		

RIM AND SPOKES

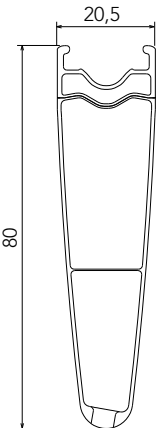

FRONT RIM	WH-013BUU80 (no labels)
REAR RIM	WH-014BUU80 (no labels)
LABEL KIT	LAB-BUU1280 (front+rear) - LAB-BUU1280DK (front+rear DARK)
VALVE HOLE	6,5 mm
2-Way Fit™ VALVE	WH-SH001
VALVE HOLE BUSHING	5-WH-SH002 (for valve seat reduction - 5 pieces)
VALVE EXTENSION	UT-WH110M (male extension) - UT-WH140F (female extension)
DIAMETER	634mm
TYRE	See recommended tyre manufacturer inflation pressure
COMPLETE FRONT KIT	KIT-03BUU80 (16 front spokes + 16 nuts + 16 nut supporting plates)
COMPLETE REAR KIT	KIT-04BUU80 (12 rear right spokes+6 rear left spokes+18 nut+18 nut supporting plates)
MINI-KIT	KIT-500BUU80 (2 front spokes + 2 rear right spokes + 2 rear right spokes + 6 nuts + 6 nut supporting plates)
NIPPLES	WH-015BUU (red - 10 pieces)
SPOKE RING	UT-WH010 (anti-rotation spokes)
INSERT NIPPLE	UT-WH160 (magnet-attractor for nipple)
NIPPLE MAGNET	UT-WH050 (nipple-guide)
SPOKE SPANNER	UT-WH090 (spoke wrenches)

HUBS

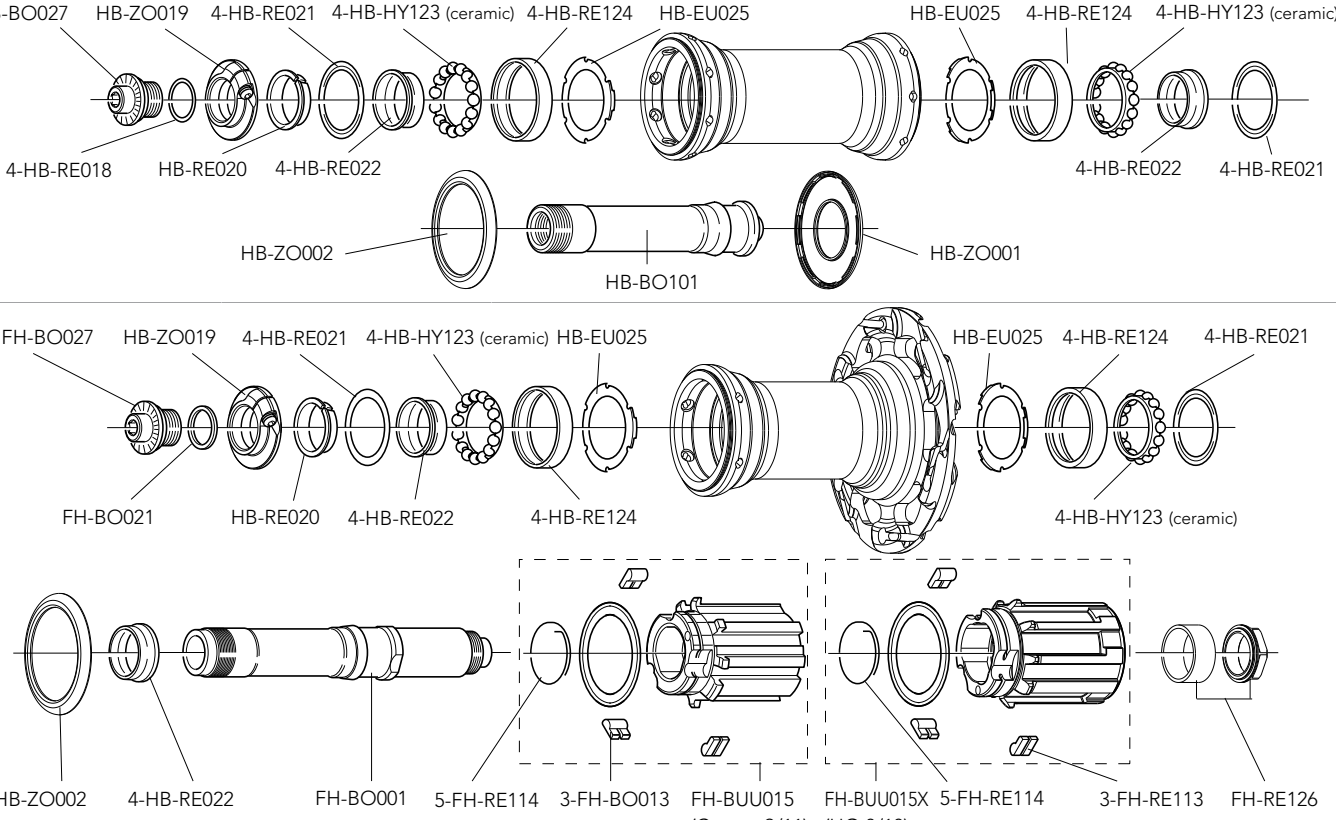

FRONT HUB COMPONENTS: HB-BO027, HB-ZO019, 4-HB-RE021, 4-HB-HY123 (ceramic), 4-HB-RE124, HB-EU025, HB-EU025, 4-HB-RE124, 4-HB-HY123 (ceramic), 4-HB-RE021, 4-HB-RE022, 4-HB-RE022, 4-HB-RE022, HB-ZO002, HB-BO101, HB-ZO001

REAR HUB COMPONENTS: FH-BO027, HB-ZO019, 4-HB-RE021, 4-HB-HY123 (ceramic), HB-EU025, HB-EU025, 4-HB-RE124, 4-HB-RE021, FH-BO021, HB-RE020, 4-HB-RE022, 4-HB-RE124, 4-HB-HY123 (ceramic), HB-ZO002, 4-HB-RE022, FH-BO001, 5-FH-RE114, 3-FH-BO013, FH-BUU015, FH-BUU015X, 5-FH-RE114, 3-FH-RE113, FH-RE126 (Campy 9/11) (HG 8/10)

QUICK-RELEASES	QR12-BUUBFR	front + rear
----------------	-------------	--------------

NOTES

BULLET™ ULTRA 2-Way Fit™ (H80 - CULT™ bearings)

HIGH PROFILE

INTENDED USE	WHEEL CODES	DESCRIPTION	WEIGHT	
This product has been designed and manufactured to be fitted and used only on "racing" or "cyclocross" bikes (if they bear the CX mark), and any other use is expressly excluded. Any other use of this product (like, for instance, cross country, all mountain-enduro, acrobatic off-road, downhill, fourcross, freeride, free-style or any other type of extreme off-road cycling as defined by UCI) can cause accidents, injuries and even death and is therefore expressly forbidden	WH12-BUU2FRC80	FRONT+REAR Campagnolo FW body - CULT	1.770	
	WH12-BUU2FRXC80	FRONT+REAR HG type FW body - CULT	1.809	
	WH12-BUU2FC80	front - CULT	815	
	WH12-BUU2RC80	rear Campagnolo FW body - CULT	955	
	WH12-BUU2RXC80	rear HG type FW body - CULT	994	
	DARK LABEL			
	WH12-BUU2FRC80DK	FRONT+REAR Campagnolo FW body - CULT	1.770	
	WH12-BUU2FRXC80DK	FRONT+REAR HG type FW body - CULT	1.809	
	WH12-BUU2FC80DK	front - CULT	815	
	WH12-BUU2RC80DK	rear Campagnolo FW body - CULT	955	
WH12-BUU2RXC80DK	rear HG type FW body - CULT	994		

RIM AND SPOKES

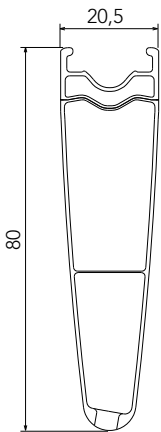

- FRONT RIM
- REAR RIM
- LABEL KIT
- VALVE HOLE
- 2-Way Fit™ VALVE
- VALVE HOLE BUSHING
- VALVE EXTENSION
- DIAMETER
- TYRE
- COMPLETE FRONT KIT
- COMPLETE REAR KIT
- MINI-KIT
- NIPPLES
- SPOKE RING
- INSERT NIPPLE
- NIPPLE MAGNET
- SPOKE SPANNER

- WH-013BUU80 (no labels)
- WH-014BUU80 (no labels)
- LAB-BUU1280 (front+rear) - LAB-BUU1280DK (front+rear DARK)
- 6,5 mm
- WH-SH001
- 5-WH-SH002 (for valve seat reduction - 5 pieces)
- UT-WH110M (male extension) - UT-WH140F (female extension)
- 634mm
- See recommended tyre manufacturer inflation pressure
- KIT-03BUU80 (16 front spokes + 16 nuts + 16 nut supporting plates)
- KIT-04BUU80 (12 rear right spokes+6 rear left spokes+18 nuts+18 nut supporting plates)
- KIT-500BUU80 (2 front spokes + 2 rear right spokes + 2 rear left spokes + 6 nuts + 6 nut supporting plates)
- WH-015BUU (red - 10 pieces)
- UT-WH010 (anti-rotation spokes)
- UT-WH160 (magnet-tractor for nipple)
- UT-WH050 (nipple-guide)
- UT-WH090 (spoke wrenches)

HUBS

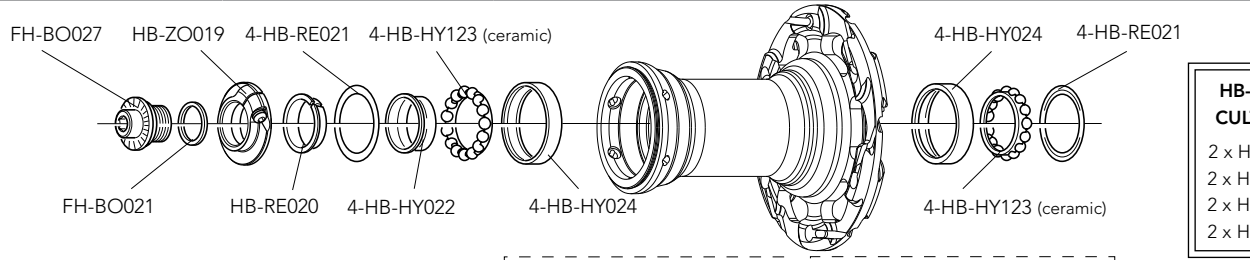
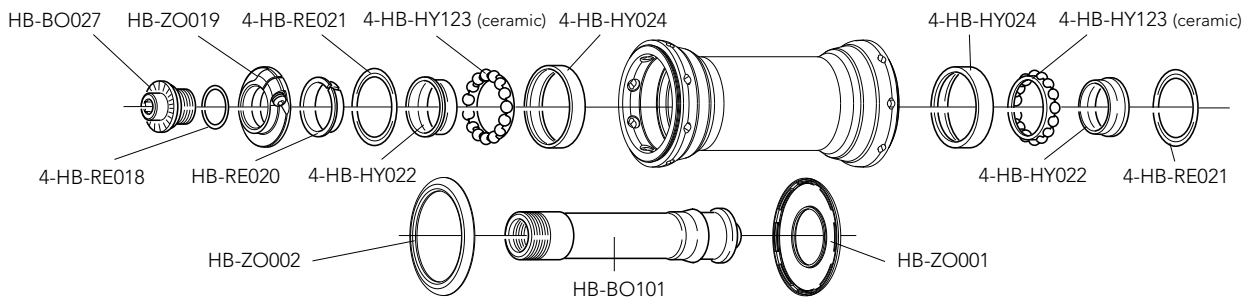

HB-HY100 CULT™ KIT
 2 x HB-RE021
 2 x HB-HY022
 2 x HB-HY024
 2 x HB-HY123

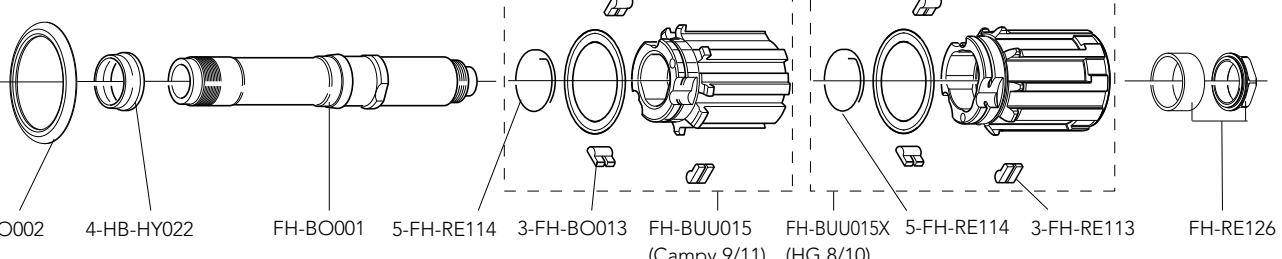

QUICK-RELEASES	QR12-BUUBFR	front + rear
----------------	-------------	--------------

NOTES

BULLET™ ULTRA 2-Way Fit™ (H105 - standard bearings)

HIGH PROFILE

INTENDED USE	WHEEL CODES	DESCRIPTION	WEIGHT	
This product has been designed and manufactured to be fitted and used only on "racing" or "cyclocross" bikes (if they bear the CX mark), and any other use is expressly excluded. Any other use of this product (like, for instance, cross country, all mountain-enduro, acrobatic off-road, downhill, fourcross, freeride, free-style or any other type of extreme off-road cycling as defined by UCI) can cause accidents, injuries and even death and is therefore expressly forbidden	WH12-BUU2FR105	FRONT+REAR Campagnolo FW body	1.960	
	WH12-BUU2FRX105	FRONT+REAR HG type FW body	1.999	
	WH12-BUU2F105	front	910	
	WH12-BUU2R105	rear Campagnolo FW body	1.050	
	WH12-BUU2RX105	rear HG type FW body	1.089	
	DARK LABEL			
	WH12-BUU2FR105DK	FRONT+REAR Campagnolo FW body	1.960	
	WH12-BUU2FRX105DK	FRONT+REAR HG type FW body	1.999	
	WH12-BUU2F105DK	front	910	
	WH12-BUU2R105DK	rear Campagnolo FW body	1.050	
WH12-BUU2R105XDK	rear HG type FW body	1.089		

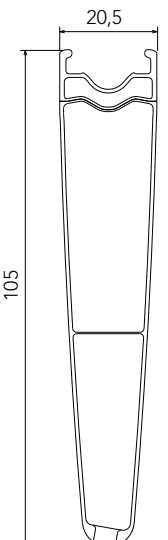
RIM AND SPOKES	
	<p>FRONT RIM REAR RIM LABEL KIT VALVE HOLE 2-Way Fit™ VALVE VALVE HOLE BUSHING VALVE EXTENSION DIAMETER TYRE</p> <p>COMPLETE FRONT KIT COMPLETE REAR KIT MINI-KIT</p> <p>NIPPLES SPOKE RING INSERT NIPPLE NIPPLE MAGNET SPOKE SPANNER</p>
	<p>WH-013BUU105 (no labels) WH-014BUU105 (no labels) LAB-BUU12105 (front+rear) - LAB-BUU12105DK (front+rear DARK) 6,5 mm WH-SH001 5-WH-SH002 (for valve seat reduction - 5 pieces) UT-WH120M (male extension) - UT-WH150F (female extension) 634mm See recommended tyre manufacturer inflation pressure</p> <p>KIT-03BUU105 (16 front spokes + 16 nuts + 16 nut supporting plates) KIT-04BUU105 (12 rear right spokes+6 rear left spokes+18 nuts+18 nut supporting plates) KIT-500BUU105 (2 front spokes + 2 rear right spokes + 2 rear left spokes + 6 nuts + 6 nut supporting plates)</p> <p>WH-015BUU (red - 10 pieces) UT-WH010 (anti-rotation spokes) UT-WH160 (magnet-attractor for nipple) UT-WH050 (nipple-guide) UT-WH090 (spoke wrenches)</p>

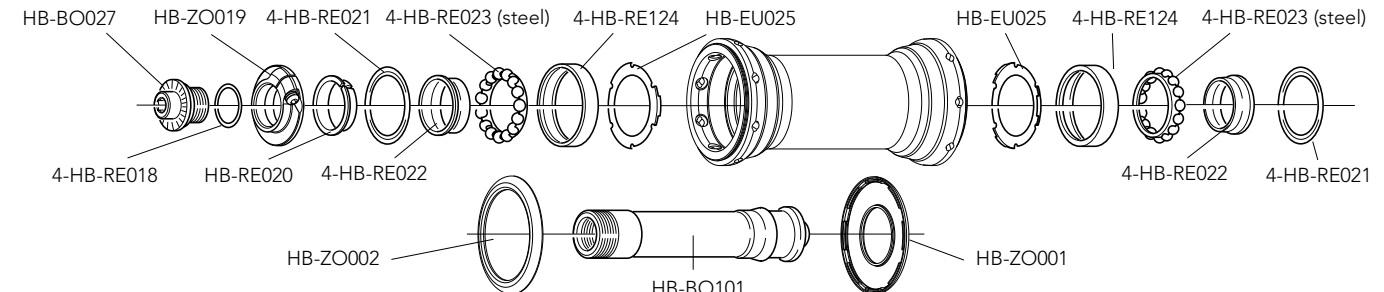
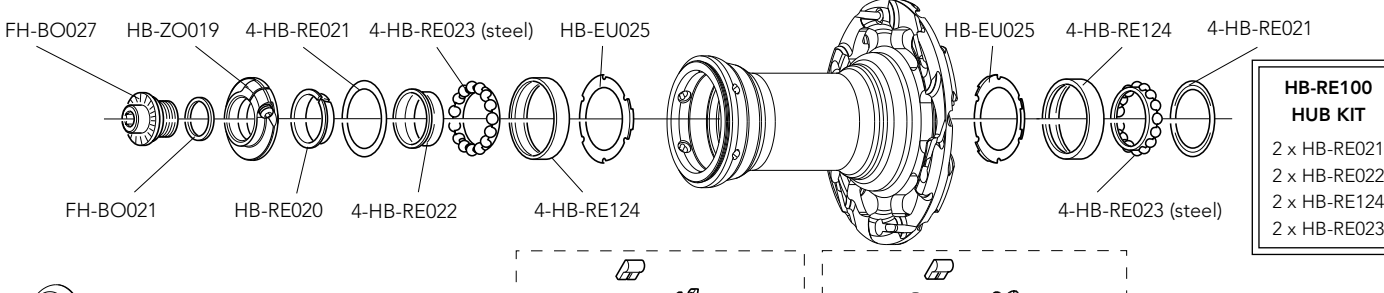
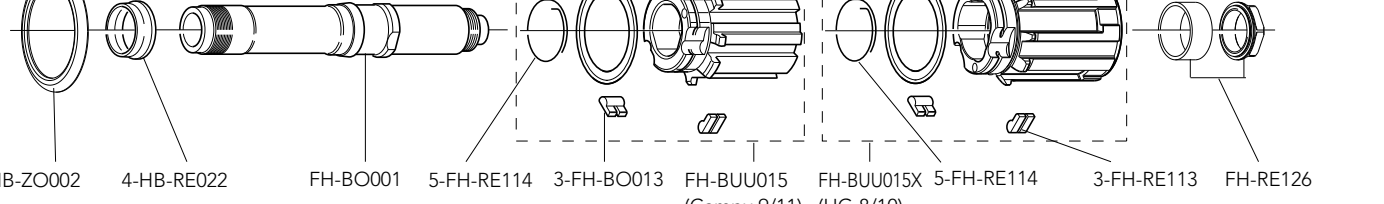
HUBS	
	
	<p>HB-RE100 HUB KIT 2 x HB-RE021 2 x HB-RE022 2 x HB-RE124 2 x HB-RE023</p>
	

QUICK-RELEASES	QR12-BUUBFR	front + rear
----------------	-------------	--------------

NOTES

BULLET™ ULTRA 2-Way Fit™ (H105 - USB™ bearings)

HIGH PROFILE

INTENDED USE	WHEEL CODES	DESCRIPTION	WEIGHT	
This product has been designed and manufactured to be fitted and used only on "racing" or "cyclocross" bikes (if they bear the CX mark), and any other use is expressly excluded. Any other use of this product (like, for instance, cross country, all mountain-enduro, acrobatic off-road, downhill, fourcross, freeride, free-style or any other type of extreme off-road cycling as defined by UCI) can cause accidents, injuries and even death and is therefore expressly forbidden	WH12-BUU2FRU105	FRONT+REAR Campagnolo FW body - USB	1.960	
	WH12-BUU2FRXU105	FRONT+REAR HG type FW body - USB	1.999	
	WH12-BUU2FU105	front - USB	910	
	WH12-BUU2RU105	rear Campagnolo FW body - USB	1.050	
	WH12-BUU2RXU105	rear HG type FW body - USB	1.089	
	DARK LABEL			
	WH12-BUU2FRU105DK	FRONT+REAR Campagnolo FW body - USB	1.960	
	WH12-BUU2FRXU105DK	FRONT+REAR HG type FW body - USB	1.999	
	WH12-BUU2FU105DK	front - USB	910	
	WH12-BUU2RU105DK	rear Campagnolo FW body - USB	1.050	
WH12-BUU2RXU105DK	rear HG type FW body - USB	1.089		

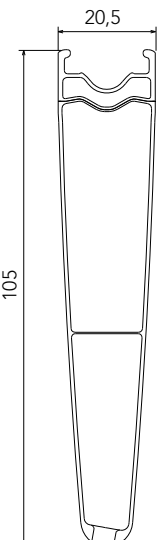
RIM AND SPOKES	
	<p>FRONT RIM REAR RIM LABEL KIT VALVE HOLE 2-Way Fit™ VALVE VALVE HOLE BUSHING VALVE EXTENSION DIAMETER TYRE</p> <p>COMPLETE FRONT KIT COMPLETE REAR KIT MINI-KIT</p> <p>NIPPLES SPOKE RING INSERT NIPPLE NIPPLE MAGNET SPOKE SPANNER</p>
	<p>WH-013BUU105 (no labels) WH-014BUU105 (no labels) LAB-BUU12105 (front+rear) - LAB-BUU12105DK (front+rear DARK) 6,5 mm WH-SH001 5-WH-SH002 (for valve seat reduction - 5 pieces) UT-WH120M (male extension) - UT-WH150F (female extension) 634mm See recommended tyre manufacturer inflation pressure</p> <p>KIT-03BUU105 (16 front spokes + 16 nuts + 16 nut supporting plates) KIT-04BUU105 (12 rear right spokes+6 rear left spokes+18 nuts+18 nut supporting plates) KIT-500BUU105 (2 front spokes + 2 rear right spokes + 2 rear left spokes + 6 nuts + 6 nut supporting plates) WH-015BUU (red - 10 pieces) UT-WH010 (anti-rotation spokes) UT-WH160 (magnet-attractor for nipple) UT-WH050 (nipple-guide) UT-WH090 (spoke wrenches)</p>

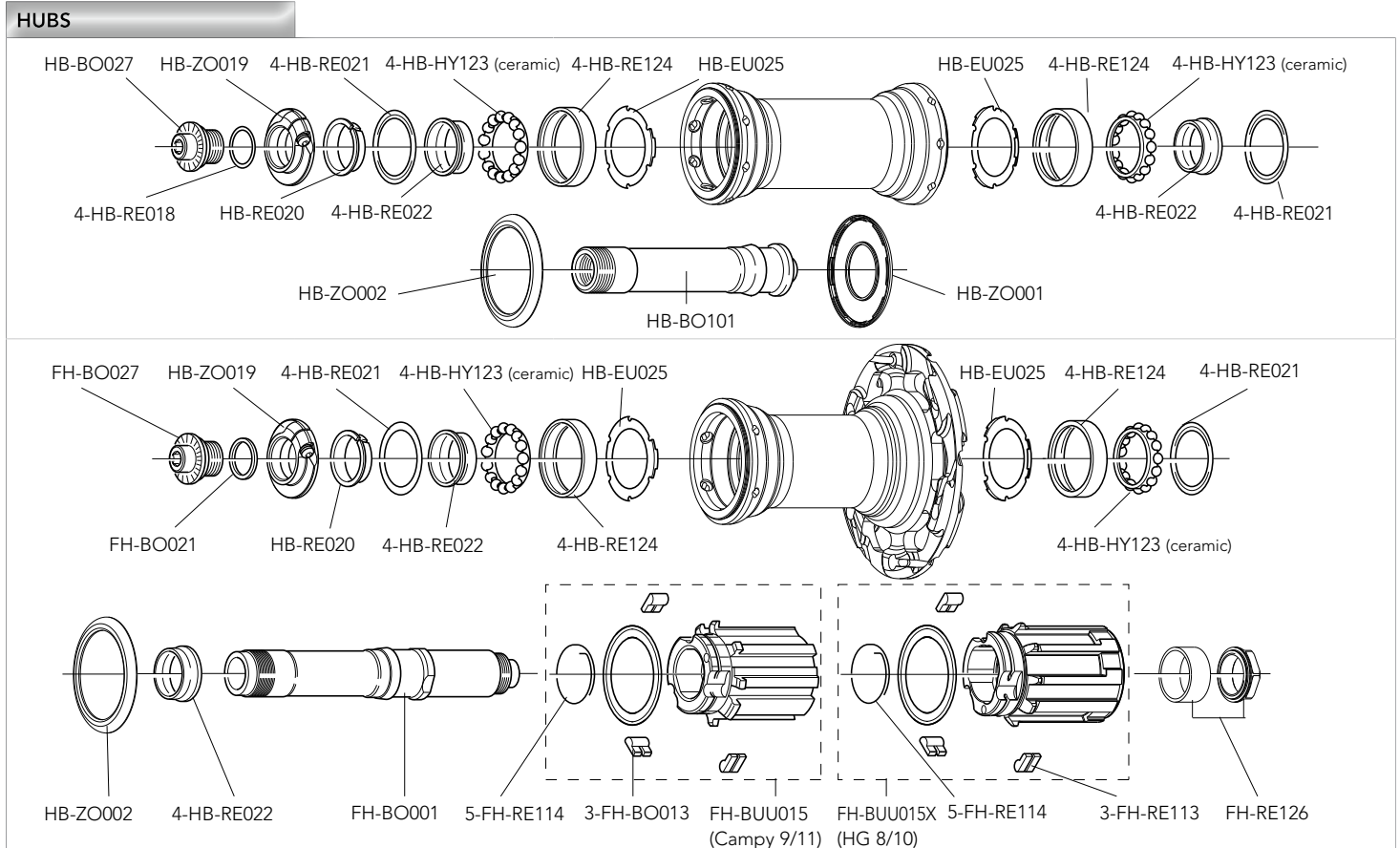

QUICK-RELEASES	QR12-BUUBFR	front + rear
----------------	-------------	--------------

NOTES

BULLET™ ULTRA 2-Way Fit™ (H105 - CULT™ bearings)

HIGH PROFILE

INTENDED USE	WHEEL CODES	DESCRIPTION	WEIGHT
This product has been designed and manufactured to be fitted and used only on "racing" or "cyclocross" bikes (if they bear the CX mark), and any other use is expressly excluded. Any other use of this product (like, for instance, cross country, all mountain-enduro, acrobatic off-road, downhill, fourcross, freeride, free-style or any other type of extreme off-road cycling as defined by UCI) can cause accidents, injuries and even death and is therefore expressly forbidden	WH12-BUU2FRC105	FRONT+REAR Campagnolo FW body - CULT	1.960
	WH12-BUU2FRXC105	FRONT+REAR HG type FW body - CULT	1.999
	WH12-BUU2FC105	front - CULT	910
	WH12-BUU2RC105	rear Campagnolo FW body - CULT	1.050
	WH12-BUU2RXC105	rear HG type FW body - CULT	1.089
	DARK LABEL		
WH12-BUU2FRC105DK	FRONT+REAR Campagnolo FW body - CULT	1.960	
WH12-BUU2FRXC105DK	FRONT+REAR HG type FW body - CULT	1.999	
WH12-BUU2FC105DK	front - CULT	910	
WH12-BUU2RC105DK	rear Campagnolo FW body - CULT	1.050	
WH12-BUU2RXC105DK	rear HG type FW body - CULT	1.089	

RIM AND SPOKES

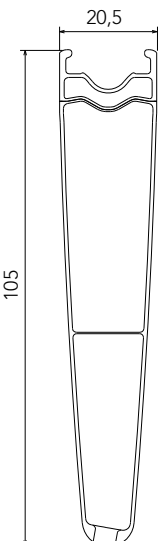

FRONT RIM
 REAR RIM
 LABEL KIT
 VALVE HOLE
 2-Way Fit™ VALVE
 VALVE HOLE BUSHING
 VALVE EXTENSION
 DIAMETER
 TYRE

COMPLETE FRONT KIT
 COMPLETE REAR KIT
 MINI-KIT

NIPPLES
 SPOKE RING
 INSERT NIPPLE
 NIPPLE MAGNET
 SPOKE SPANNER

WH-013BUU105 (no labels)
 WH-014BUU105 (no labels)
 LAB-BUU12105 (front+rear) - LAB-BUU12105DK (front+rear DARK)
 6,5 mm
 WH-SH001
 5-WH-SH002 (for valve seat reduction - 5 pieces)
 UT-WH120M (male extension) - UT-WH150F (female extension)
 634mm
 See recommended tyre manufacturer inflation pressure

KIT-03BUU105 (16 front spokes + 16 nuts + 16 nut supporting plates)
 KIT-04BUU105 (12 rear right spokes+6 rear left spokes+18 nuts+18 nut supporting plates)
 KIT-500BUU105 (2 front spokes + 2 rear right spokes + 2 rear left spokes + 6 nuts + 6 nut supporting plates)
 WH-015BUU (red - 10 pieces)
 UT-WH010 (anti-rotation spokes)
 UT-WH160 (magnet-attractor for nipple)
 UT-WH050 (nipple-guide)
 UT-WH090 (spoke wrenches)

HUBS

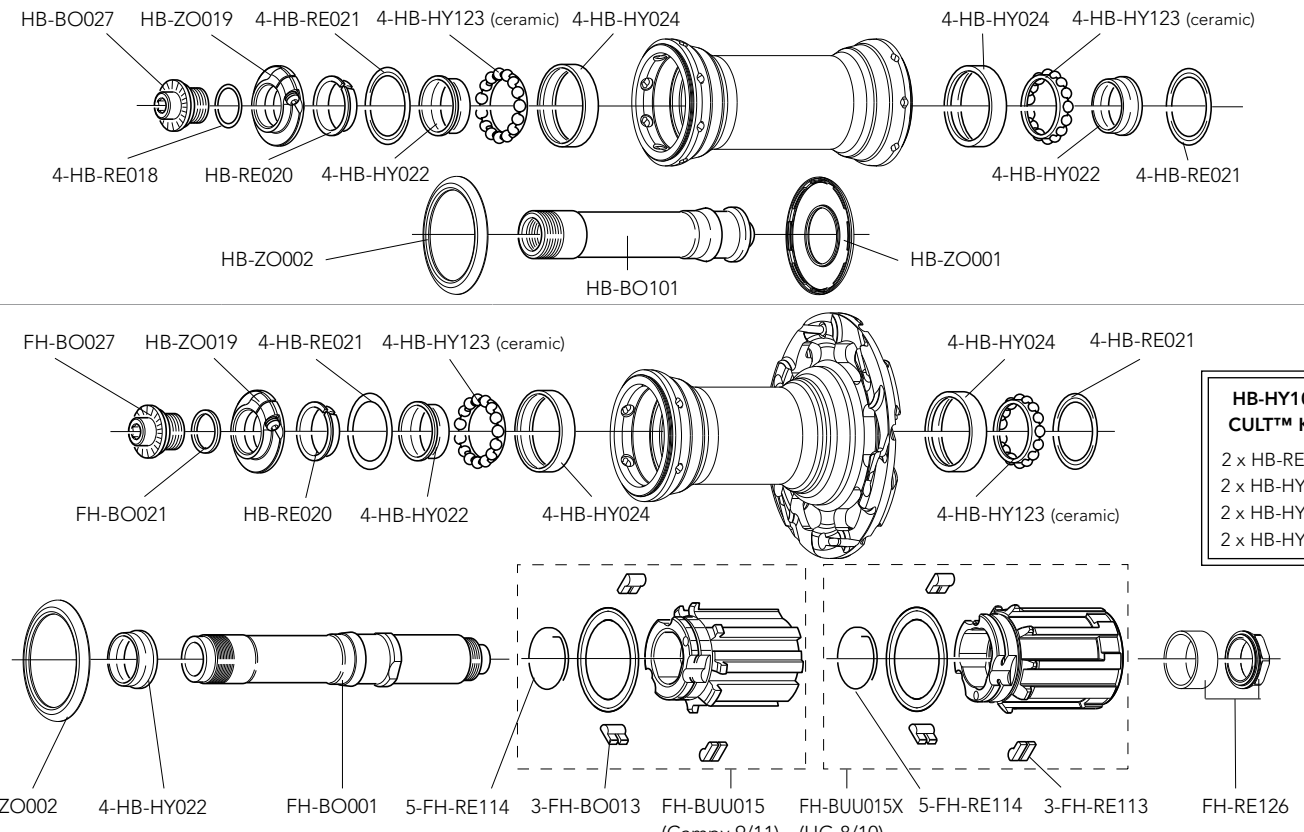

HB-BO027 HB-ZO019 4-HB-RE021 4-HB-HY123 (ceramic) 4-HB-HY024
 4-HB-RE018 HB-RE020 4-HB-HY022 4-HB-HY024 4-HB-HY123 (ceramic)
 4-HB-HY022 4-HB-RE021
 HB-ZO002 HB-BO101 HB-ZO001

FH-BO027 HB-ZO019 4-HB-RE021 4-HB-HY123 (ceramic) 4-HB-HY024 4-HB-RE021
 FH-BO021 HB-RE020 4-HB-HY022 4-HB-HY024 4-HB-HY123 (ceramic)

HB-ZO002 4-HB-HY022 FH-BO001 5-FH-RE114 3-FH-BO013 FH-BUU015 FH-BUU015X 5-FH-RE114 3-FH-RE113 FH-RE126
 (Campy 9/11) (HG 8/10)

HB-HY100 CULT™ KIT
 2 x HB-RE021
 2 x HB-HY022
 2 x HB-HY024
 2 x HB-HY123

QUICK-RELEASES	QR12-BUUBFR	front + rear
----------------	-------------	--------------

NOTES

BORA™ ONE tubular

LOW PROFILE

INTENDED USE	WHEEL CODES	DESCRIPTION	WEIGHT	
This product has been designed and manufactured to be fitted and used only on "racing" or "cyclocross" bikes (if they bear the CX mark), and any other use is expressly excluded. Any other use of this product (like, for instance, cross country, all mountain-enduro, acrobatic off-road, downhill, fourcross, freeride, free-style or any other type of extreme off-road cycling as defined by UCI) can cause accidents, injuries and even death and is therefore expressly forbidden	WH10-BOTFR1	FRONT+REAR Campagnolo FW body+brake shoes BR-BO500	1.350	
	WH10-BOTFRX1	FRONT+REAR HG type FW body+brake shoes BR-BO500X	1.389	
	WH10-BOTF1	front+brake shoes BR-BO500	590	
	WH10-BOTFX1	front+brake shoes BR-BO500X	590	
	WH10-BOTR1	rear Campagnolo FW body+brake shoes BR-BO500	760	
	WH10-BOTRX1	rear HG type FW body+brake shoes BR-BO500X	799	
	DARK LABEL			
	WH12-BOTFR1DK	FRONT+REAR Campagnolo FW body+brake shoes BR-BO500	1.350	
	WH12-BOTFRX1DK	FRONT+REAR HG type FW body+brake shoes BR-BO500X	1.389	
	WH12-BOTF1DK	front+brake shoes BR-BO500	590	
	WH12-BOTFX1DK	front+brake shoes BR-BO500X	590	
	WH12-BOTR1DK	rear Campagnolo FW body+brake shoes BR-BO500	760	
	WH12-BOTRX1DK	rear HG type FW body+brake shoes BR-BO500X	799	

RIM

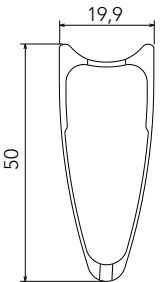

FRONT RIM
REAR RIM
LABEL KIT
VALVE HOLE
VALVE EXTENSION
DIAMETER
TYRE
BRAKE SHOES

WH-001BO1 (with standard labels) - WH-001BO1DK (with DARK labels)
WH-002BO1 (with standard labels) - WH-002BO1DK (with DARK labels)
LAB-BO1T10 (front+rear) - LAB-BO1T10DK (front+rear DARK)
6,5 mm
UT-HU130
634 mm
See recommended tyre manufacturer inflation pressure for carbon rims - BR-BO500 (per Campagnolo brakes) - BR-BO500X (per Shimano brakes)

HUBS

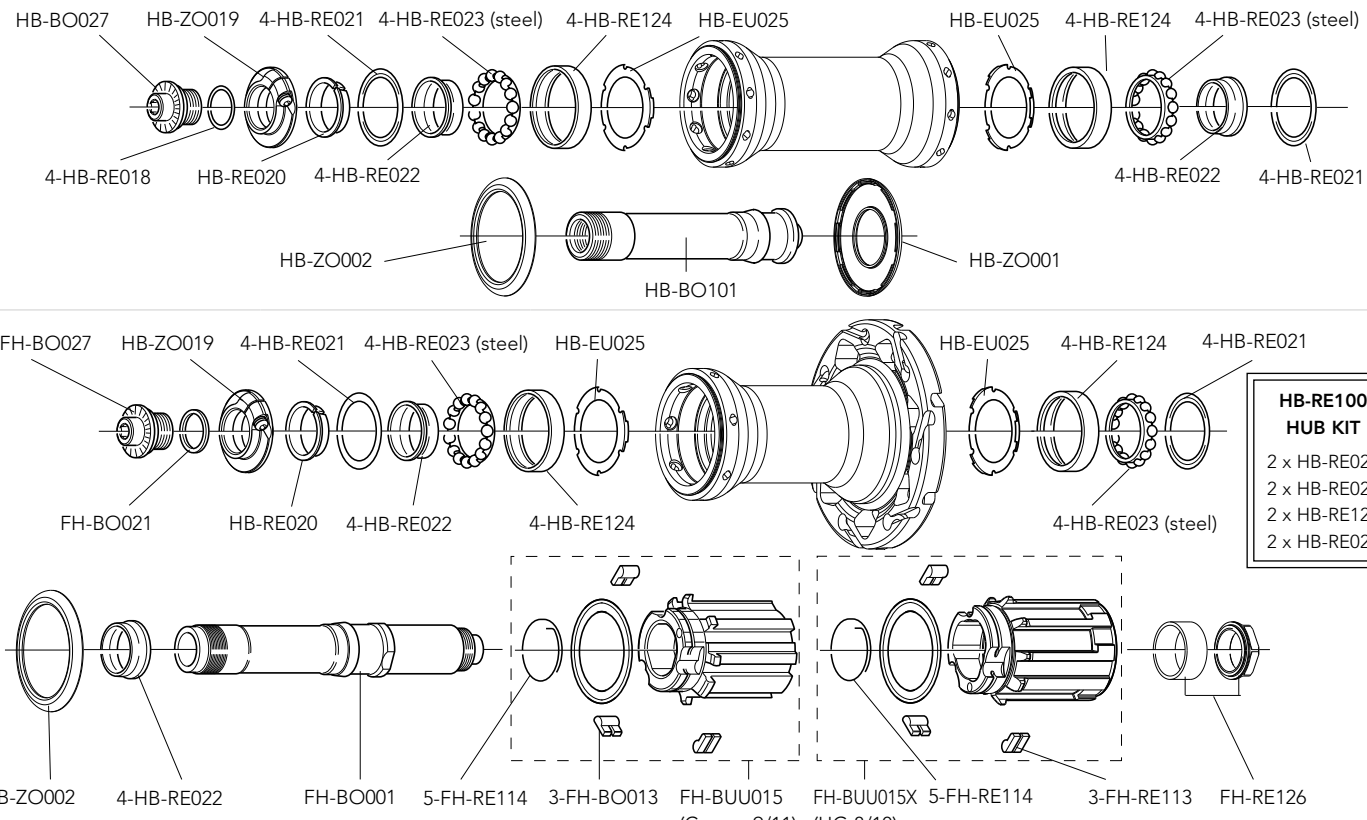

HB-BO027 HB-ZO019 4-HB-RE021 4-HB-RE023 (steel) 4-HB-RE124 HB-EU025
4-HB-RE018 HB-RE020 4-HB-RE022 4-HB-RE022 4-HB-RE021
HB-ZO002 HB-BO101 HB-ZO001

FH-BO027 HB-ZO019 4-HB-RE021 4-HB-RE023 (steel) HB-EU025
FH-BO021 HB-RE020 4-HB-RE022 4-HB-RE124 4-HB-RE021
4-HB-RE023 (steel)

HB-RE100 HUB KIT
2 x HB-RE021
2 x HB-RE022
2 x HB-RE124
2 x HB-RE023

HB-ZO002 4-HB-RE022 FH-BO001 5-FH-RE114 3-FH-BO013 FH-BUU015 FH-BUU015X 5-FH-RE114 3-FH-RE113 FH-RE126
(Campy 9/11) (HG 8/10)

QUICK-RELEASES	QR12-BUUBFR	front + rear
----------------	-------------	--------------

SPOKES		
COMPLETE FRONT KIT	KIT-01BO1	18 front spokes + 18 nuts + 18 nut supporting plates
COMPLETE REAR KIT	KIT-02BO1	14 rear right spokes + 7 rear left spokes + 21 nuts + 21 nut supporting plates
MINI-KIT	KIT-100BO1	2 front spokes + 2 rear right spokes + 2 rear left spokes + 6 nuts + 6 nut supporting plates
NUTS	10-WH-010BO	10 pieces
NUT SUPPORTING PLATES	10-WH-011BO	10 pieces

! WARNING!

Because of the high temperatures reached when breaking, we recommend you use only glue for tubular tires specifically for carbon fibre rims.

BORA™ ULTRA™ TWO tubular

HIGH PROFILE

INTENDED USE	WHEEL CODES	DESCRIPTION	WEIGHT	
This product has been designed and manufactured to be fitted and used only on "racing" or "cyclocross" bikes (if they bear the CX mark), and any other use is expressly excluded. Any other use of this product (like, for instance, cross country, all mountain-enduro, acrobatic off-road, downhill, fourcross, freeride, free-style or any other type of extreme off-road cycling as defined by UCI) can cause accidents, injuries and even death and is therefore expressly forbidden	WH9-BOTFR	FRONT+REAR Campagnolo FW body+brake shoes BR-BO500	1.310	
	WH9-BOTFRX	FRONT+REAR HG type FW body+brake shoes BR-BO500X	1.344	
	WH9-BOTF	front+brake shoes BR-BO500	565	
	WH9-BOTFX	front+brake shoes BR-BO500X	565	
	WH9-BOTR	rear Campagnolo FW body+brake shoes BR-BO500	745	
	WH9-BOTRX	rear HG type FW body+brake shoes BR-BO500X	779	
	DARK LABEL			
	WH12-BOTFRDK	FRONT+REAR Campagnolo FW body+brake shoes BR-BO500	1.310	
	WH12-BOTFRXDK	FRONT+REAR HG type FW body+brake shoes BR-BO500X	1.344	
	WH12-BOTFDK	front+brake shoes BR-BO500	565	
WH12-BOTFXDK	front+brake shoes BR-BO500X	565		
WH12-BOTRDK	rear Campagnolo FW body+brake shoes BR-BO500	745		
WH12-BOTRDK	rear HG type FW body+brake shoes BR-BO500X	779		

RIM

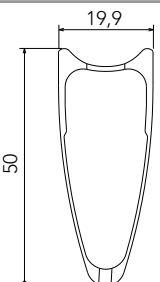

FRONT RIM REAR RIM LABEL KIT VALVE HOLE VALVE EXTENSION DIAMETER TYRE BRAKE SHOES	WH-601BO (with standard labels) - WH-101BODK (with DARK labels) WH-502BO (with standard labels) - WH-102BODK (with DARK labels) LAB-BOT9 (front+rear) - LAB-BOT12DK (front+rear DARK) 6,5 mm UT-HU130 634 mm See recommended tyre manufacturer inflation pressure for carbon rims - BR-BO500 (per Campagnolo brakes) - BR-BO500X (per Shimano brakes)
--------------------------------------------------------------------------------------------------------	----------------------------------------------------------------------------------------------------------------------------------------------------------------------------------------------------------------------------------------------------------------------------------------------------------------------------------------------------------------------------

HUBS

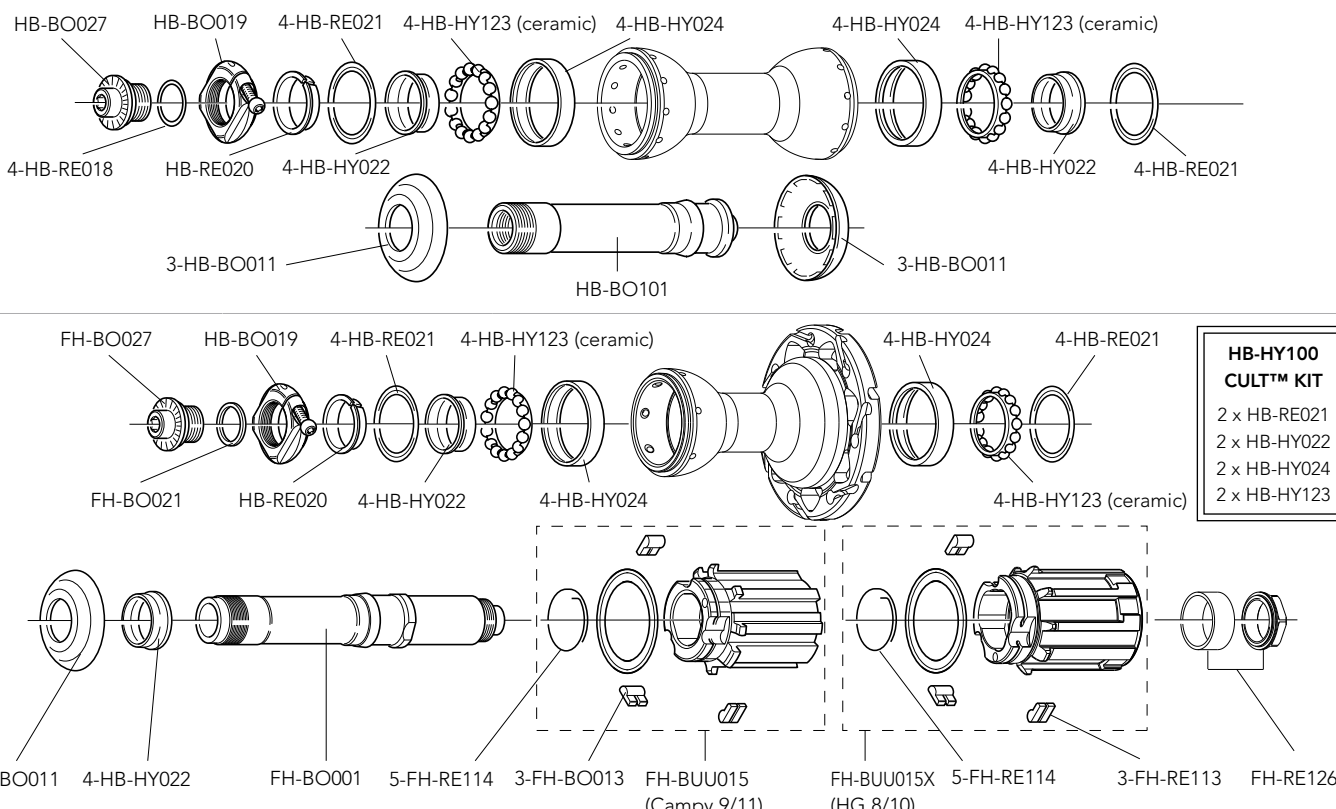

Labels for front hub: HB-BO027, HB-BO019, 4-HB-RE021, 4-HB-HY123 (ceramic), 4-HB-HY024, 4-HB-HY024, 4-HB-HY123 (ceramic), 4-HB-HY022, 4-HB-RE021, 3-HB-BO011, HB-BO101, 3-HB-BO011.

Labels for rear hub: FH-BO027, HB-BO019, 4-HB-RE021, 4-HB-HY123 (ceramic), 4-HB-HY024, 4-HB-RE021, FH-BO021, HB-RE020, 4-HB-HY022, 4-HB-HY024, 4-HB-HY123 (ceramic), 3-HB-BO011, 4-HB-HY022, FH-BO001, 5-FH-RE114, 3-FH-BO013, FH-BUU015 (Campy 9/11), FH-BUU015X (HG 8/10), 5-FH-RE114, 3-FH-RE113, FH-RE126.

HB-HY100 CULT™ KIT
 2 x HB-RE021
 2 x HB-HY022
 2 x HB-HY024
 2 x HB-HY123

QUICK-RELEASES	QR12-BUUBFR	front + rear
----------------	-------------	--------------

SPOKES

COMPLETE FRONT KIT	KIT-31BO	18 front spokes + 18 nuts + 18 nut supporting plates
COMPLETE REAR KIT	KIT-42BO	14 rear right spokes + 7 rear left spokes + 21 nuts + 21 nut supporting plates
MINI-KIT	KIT-400BO	2 front spokes. + 2 rear right spokes + 2 rear left spokes + 6 nuts + 6 nut supporting plates
NUTS	10-WH-010BO	10 pieces
NUT SUPPORTING PLATES	10-WH-011BO	10 pieces

! WARNING!

Because of the high temperatures reached when breaking, we recommend you use only glue for tubular tires specifically for carbon fibre rims.

BORA™ ULTRA™ 80 tubular

HIGH PROFILE

INTENDED USE	WHEEL CODES	DESCRIPTION	WEIGHT	
This product has been designed and manufactured to be fitted and used only on "racing" or "cyclocross" bikes (if they bear the CX mark), and any other use is expressly excluded. Any other use of this product (like, for instance, cross country, all mountain-enduro, acrobatic off-road, downhill, fourcross, freeride, free-style or any other type of extreme off-road cycling as defined by UCI) can cause accidents, injuries and even death and is therefore expressly forbidden	WH12-BOTFR80	FRONT+REAR Campagnolo FW body+brake shoes BR-BO500	1.540	
	WH12-BOTFRX80	FRONT+REAR HG type FW body+brake shoes BR-BO500X	1.579	
	WH12-BOTF80	front+brake shoes BR-BO500	715	
	WH12-BOTFX80	front+brake shoes BR-BO500X	715	
	WH12-BOTR80	rear Campagnolo FW body+brake shoes BR-BO500	825	
	WH12-BOTRX80	rear HG type FW body+brake shoes BR-BO500X	864	
	DARK LABEL			
	WH12-BOTFR80DK	FRONT+REAR Campagnolo FW body+brake shoes BR-BO500	1.540	
	WH12-BOTFRX80DK	FRONT+REAR HG type FW body+brake shoes BR-BO500X	1.579	
	WH12-BOTF80DK	front+brake shoes BR-BO500	715	
	WH12-BOTFX80DK	front+brake shoes BR-BO500X	715	
	WH12-BOTR80DK	rear Campagnolo FW body+brake shoes BR-BO500	825	
	WH12-BOTRX80DK	rear HG type FW body+brake shoes BR-BO500X	864	

RIM AND SPOKES

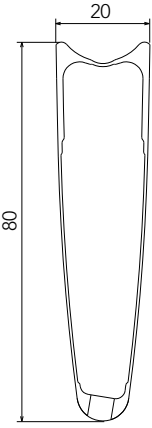
	<p>FRONT RIM REAR RIM LABEL KIT VALVE HOLE VALVE EXTENSION DIAMETER TYRE BRAKE SHOES</p>	<p>WH-001BO80 (no labels) WH-002BO80 (no labels) LAB-BOT1280 (front+rear) - LAB-BOT1280DK (front+rear DARK) 6,5 mm UT-WH160M (male extension) - UT-WH160F (female extension) 634 mm See recommended tyre manufacturer inflation pressure for carbon rims - BR-BO500 (per Campagnolo brakes) - BR-BO500X (per Shimano brakes)</p>
	<p>COMPLETE FRONT KIT COMPLETE REAR KIT MINI-KIT</p> <p>NIPPLES SPOKE RING INSERT NIPPLE NIPPLE MAGNET SPOKE SPANNER</p>	<p>KIT-03BUU80 (16 front spokes + 16 nuts + 16 nut supporting plates) KIT-04BUU80 (12 rear right spokes+6 rear left spokes+18 nuts+18 nut supporting plates) KIT-500BUU80 (2 front spokes + 2 rear right spokes + 2 rear left spokes + 6 nuts + 6 nut supporting plates) WH-015BUU (red - 10 pieces) UT-WH010 (anti-rotation spokes) UT-WH160 (magnet-attractor for nipple) UT-WH050 (nipple-guide) UT-WH090 (spoke wrenches)</p>

HUBS

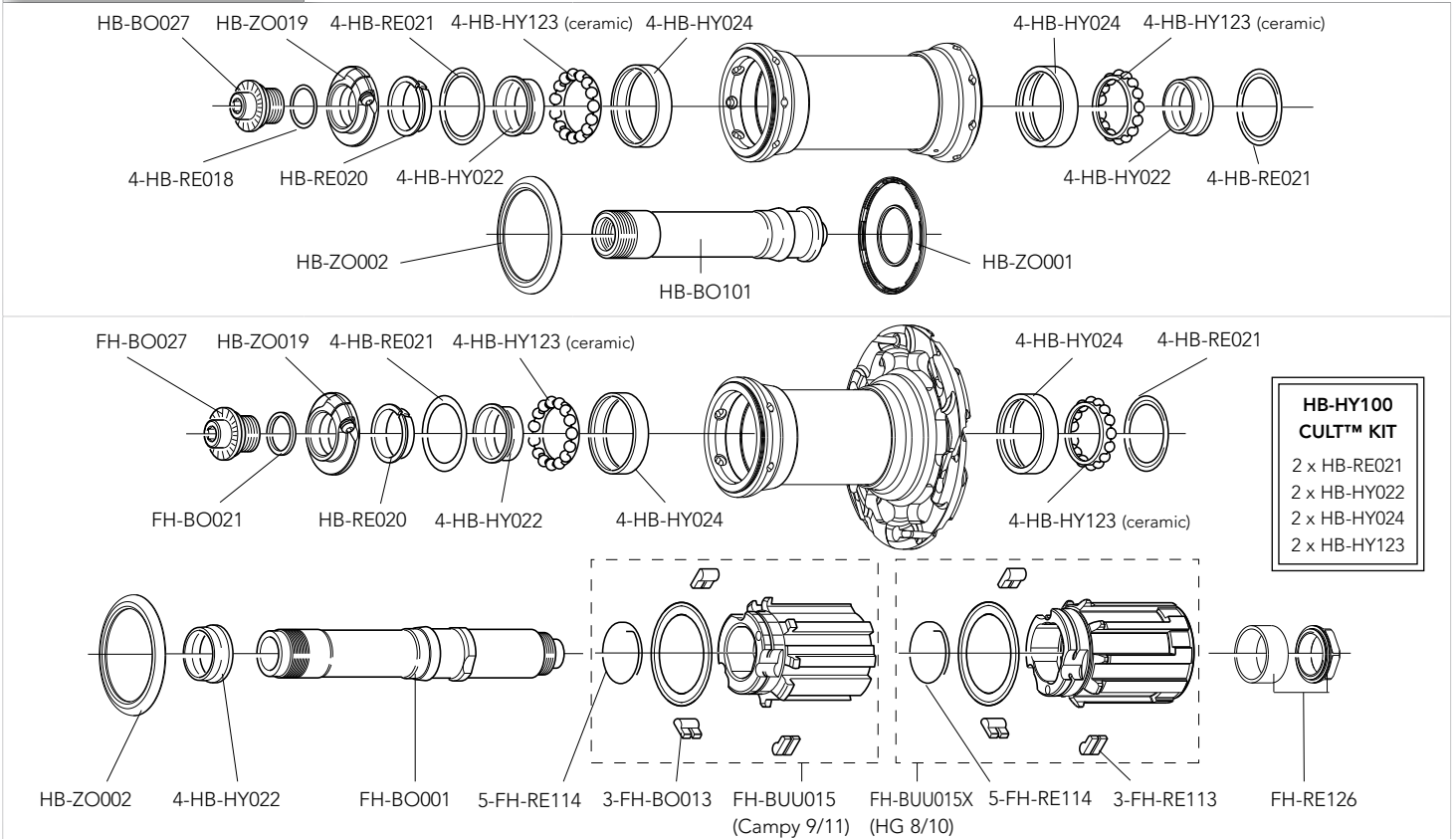

QUICK-RELEASES	QR12-BUUBFR	front + rear
----------------	-------------	--------------

! WARNING!

Because of the high temperatures reached when breaking, we recommend you use only glue for tubular tires specifically for carbon fibre rims.

GIBLI™ ULTRA™ tubular

HIGH PROFILE

INTENDED USE	WHEEL CODES	DESCRIPTION	WEIGHT
This product has been designed and manufactured to be fitted and used only on "racing" or "cyclocross" bikes (if they bear the CX mark), and any other use is expressly excluded. Any other use of this product (like, for instance, cross country, all mountain-enduro, acrobatic off-road, downhill, fourcross, freeride, free-style or any other type of extreme off-road cycling as defined by UCI) can cause accidents, injuries and even death and is therefore expressly forbidden	WH9-GHR28X	rear road	1.010
	WH9-GHPF28	front track 28"	955
	WH9-GHPR28	rear track 28"	995

RIM	
RIM	disc profile tensile-structure in aramidic fibre Braking surface in aluminium
TYRE	See recommended tyre manufacturer inflation pressure

HUBS

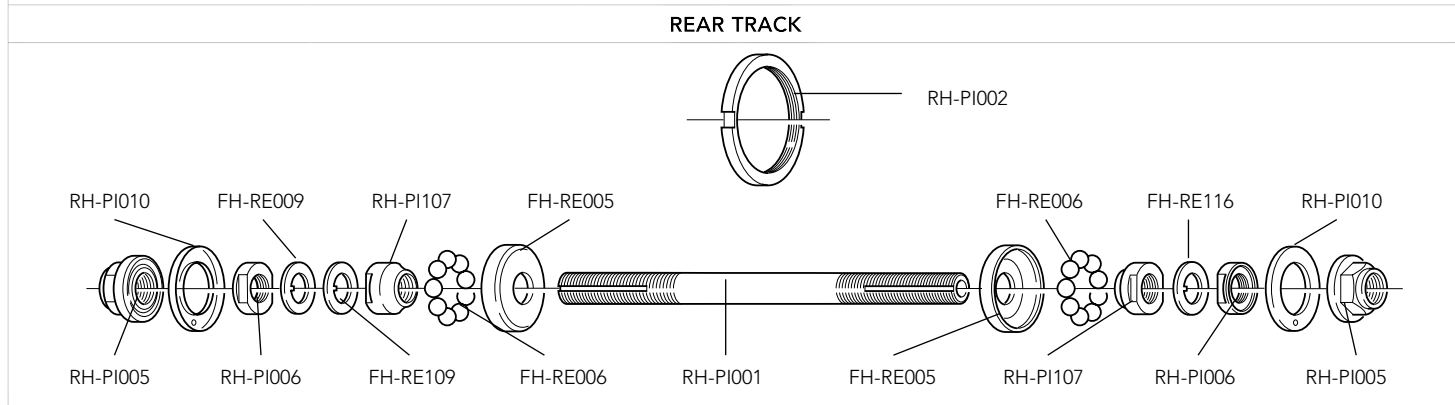
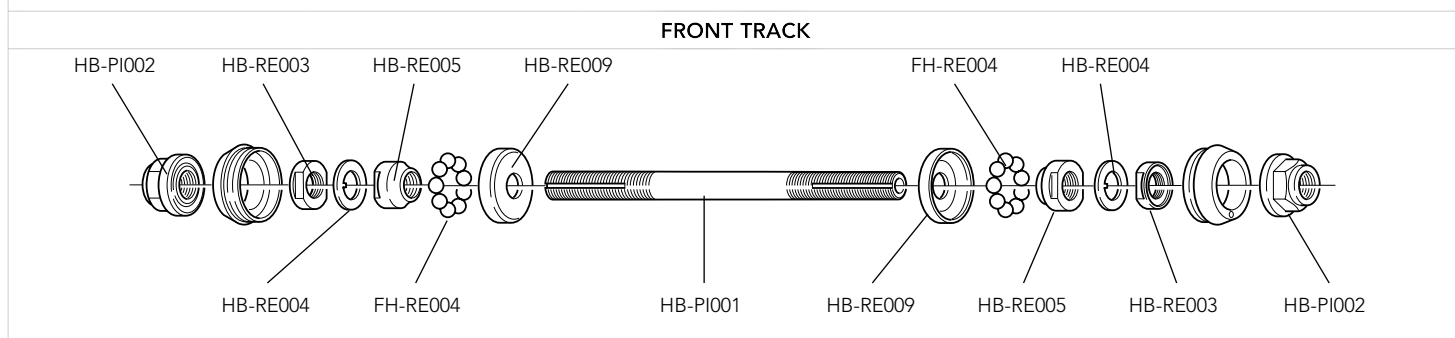
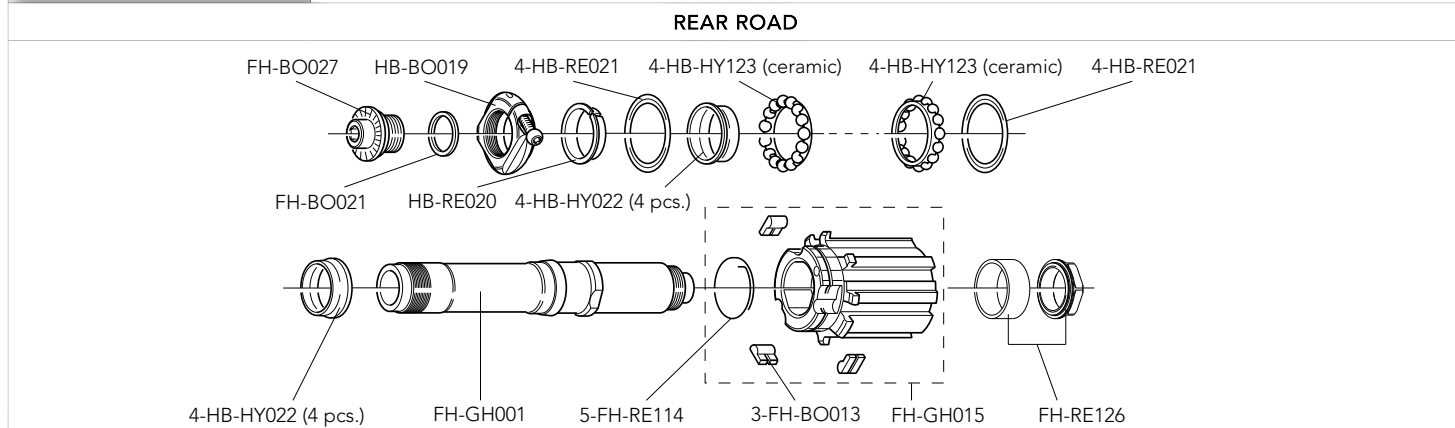

QUICK-RELEASES	QR12-BUUBFR	front + rear
----------------	-------------	--------------

NOTES

PISTA™ tubular

HIGH PROFILE

INTENDED USE	WHEEL CODES	DESCRIPTION	WEIGHT
This product has been designed and manufactured to be fitted and used only on "racing" or "cyclocross" bikes (if they bear the CX mark), and any other use is expressly excluded. Any other use of this product (like, for instance, cross country, all mountain-enduro, acrobatic off-road, downhill, fourcross, freeride, free-style or any other type of extreme off-road cycling as defined by UCI) can cause accidents, injuries and even death and is therefore expressly forbidden	WH02-PTF	front	995
	WH02-PTR	rear	1.040

RIM

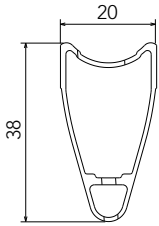

FRONT RIM
 REAR RIM
 LABEL KIT
 VALVE HOLE
 VALVE EXTENSION
 DIAMETER
 TYRE SECTION

WH-001PI (with labels)
 WH-002PI (with labels)
 LAB-PIT07 (for a pair of front+rear wheels)
 6,5 mm
 UT-HU100
 634 mm
 See recommended tyre manufacturer inflation pressure

HUBS

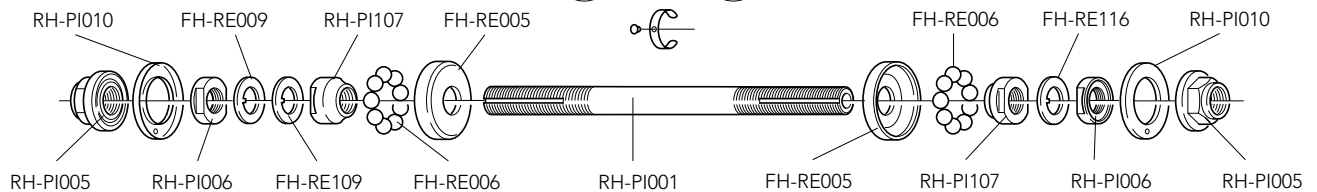
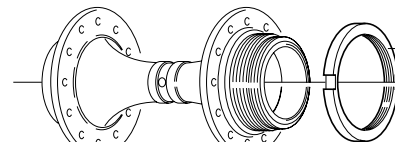
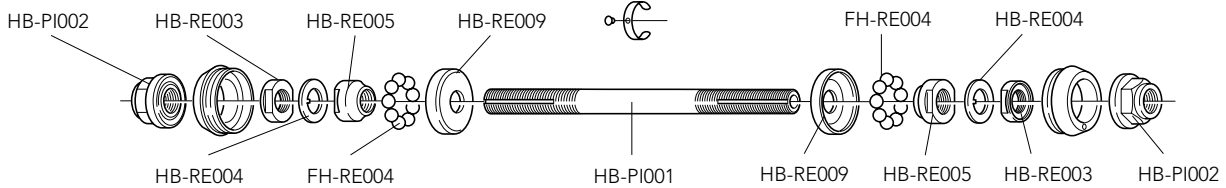
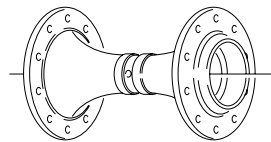

SPOKES

COMPLETE FRONT KIT	KIT-01PI	20 front spokes + 20 nuts + 20 nut supporting plates
COMPLETE REAR KIT	KIT-02PI	24 rear spokes + 24 nuts + 24 nut supporting plates
MINI-KIT	KIT-100PI	2 front spokes + rear spokes + 6 nuts + 6 nut supporting plates
NUTS	10-WH-010BO	10 pieces
NUT SUPPORTING PLATES	10-WH-011EU	10 pieces

NOTES

KHAMSIN™ CX clincher

CYCLOCROSS - MEDIUM PROFILE

INTENDED USE	WHEEL CODES	DESCRIPTION	WEIGHT
This product has been designed and manufactured to be fitted and used only on "racing" or "cyclocross" bikes (if they bear the CX mark), and any other use is expressly excluded. Any other use of this product (like, for instance, cross country, all mountain-enduro, acrobatic off-road, downhill, fourcross, freeride, free-style or any other type of extreme off-road cycling as defined by UCI) can cause accidents, injuries and even death and is therefore expressly forbidden	WH11-KHXCFRB	FRONT+REAR Campagnolo FW body	1.873
	WH12-KHXCFRXB	FRONT+REAR HG type FW body	1.912
	WH11-KHXCFB	front	828
	WH11-KHXCRB	rear Campagnolo FW body	1.045
	WH12-KHXCRXB	rear HG type FW body	1.084

RIM

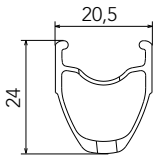

RIM-TAPE LABEL KIT VALVE HOLE DIAMETER TYRE SECTION	2-WH-RT01 (18 mm - 2 pieces) LAB-KHXCB11 (for a pair of front+rear wheels) 6,5 mm 700C (622 x 15C) See section table and inflation pressures on page 205*	* These wheels are designed to mount cyclo-cross up to 35 mm tyres. We highly recommend complying with maximum pressures indicated on cyclo-cross tyres. Do no use 29" MTB tyres.
-----------------------------------------------------------------	-----------------------------------------------------------------------------------------------------------------------------------------------------------------------	--------------------------------------------------------------------------------------------------------------------------------------------------------------------------------------

HUBS

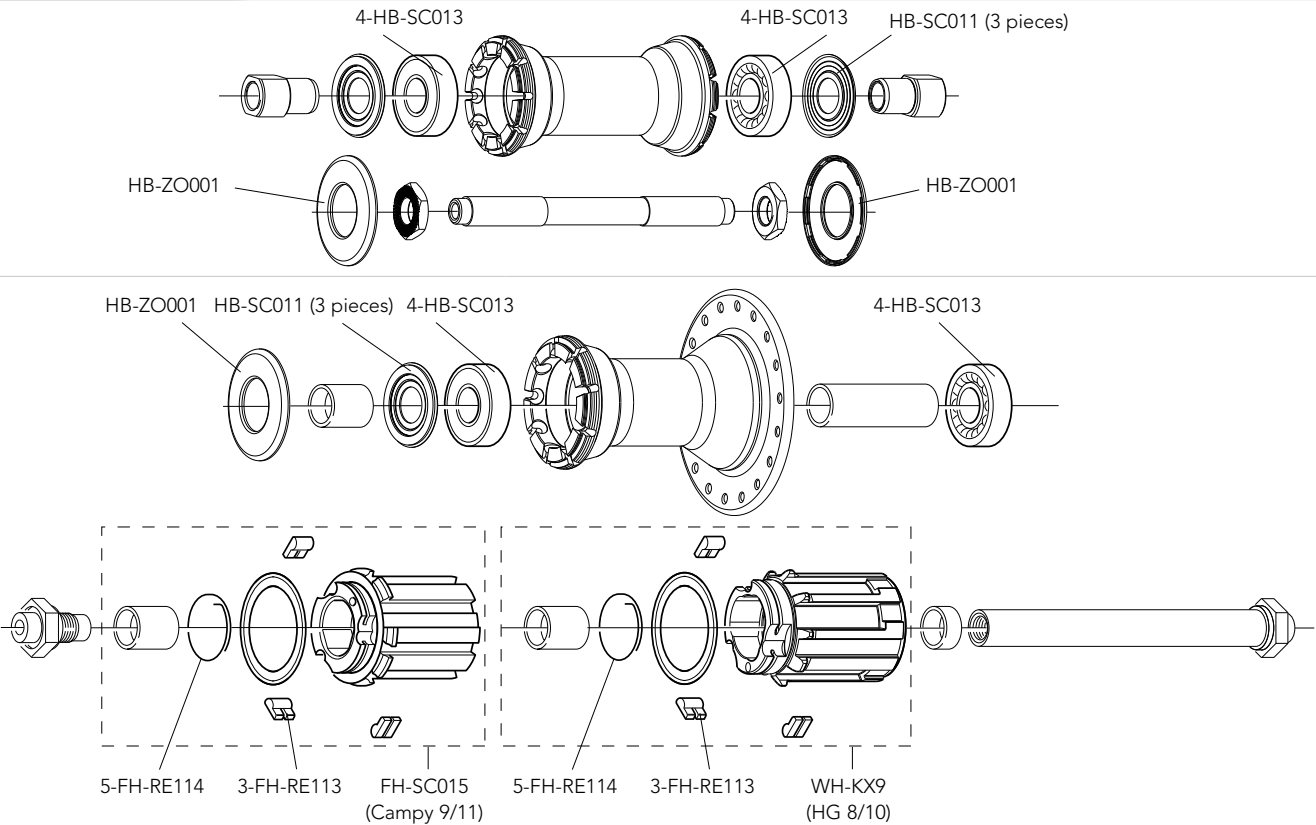

QUICK-RELEASES	QR8-40BFR	black - front + rear
----------------	-----------	----------------------

SPOKES

COMPLETE FRONT KIT	KIT-23KHB	24 front spokes + 24 nipples
COMPLETE REAR KIT	KIT-24KHB	18 rear right spokes + 9 rear left spokes + 27 nipples
MINI-KIT	KIT-300KHB	2 front spokes + 2 rear right spokes + 2 rear left spokes + 6 nipples
NIPLES	50-WH-NZO	50 pieces

NOTES

VENTO™ REACTION™ CX clincher

CYCLOCROSS - MEDIUM PROFILE

INTENDED USE	WHEEL CODES	DESCRIPTION	WEIGHT
This product has been designed and manufactured to be fitted and used only on "racing" or "cyclocross" bikes (if they bear the CX mark), and any other use is expressly excluded. Any other use of this product (like, for instance, cross country, all mountain-enduro, acrobatic off-road, downhill, fourcross, freeride, free-style or any other type of extreme off-road cycling as defined by UCI) can cause accidents, injuries and even death and is therefore expressly forbidden	WH11-VEXCFRB	FRONT+REAR Campagnolo FW body	1.827
	WH12-VEXCFRXB	FRONT+REAR HG type FW body	1.866
	WH11-VEXCFB	front	825
	WH11-VEXCRB	rear Campagnolo FW body	1.002
	WH12-VEXCRXB	rear HG type FW body	1.041

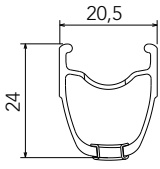
RIM			
	RIM-TAPE LABEL KIT VALVE HOLE DIAMETER TYRE SECTION	2-WH-RT01 (18 mm - 2 pieces) LAB-VEXCB11 (for a pair of front+rear wheels) 6,5 mm 700C (622 x 15C) See section table and inflation pressures on page 205*	* These wheels are designed to mount cyclo-cross up to 35 mm tyres. We highly recommend complying with maximum pressures indicated on cyclo-cross tyres. Do no use 29" MTB tyres.

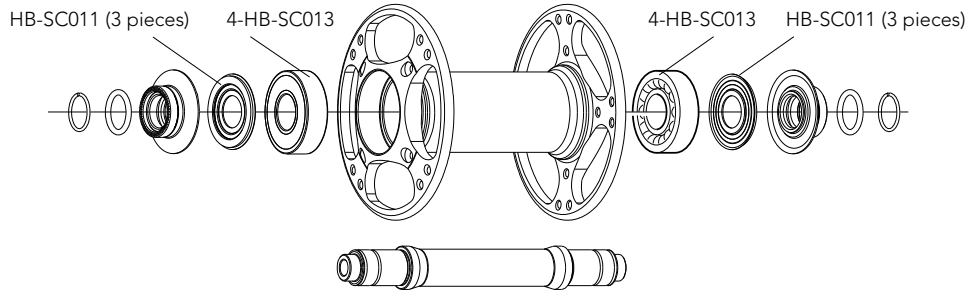
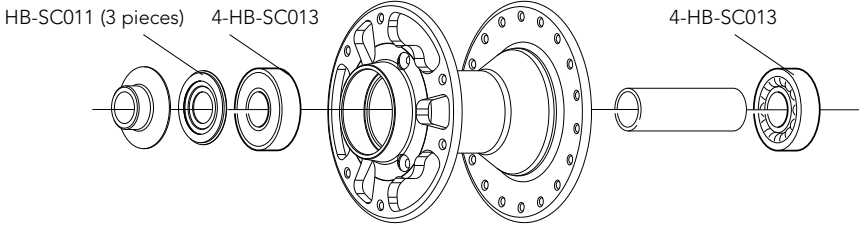
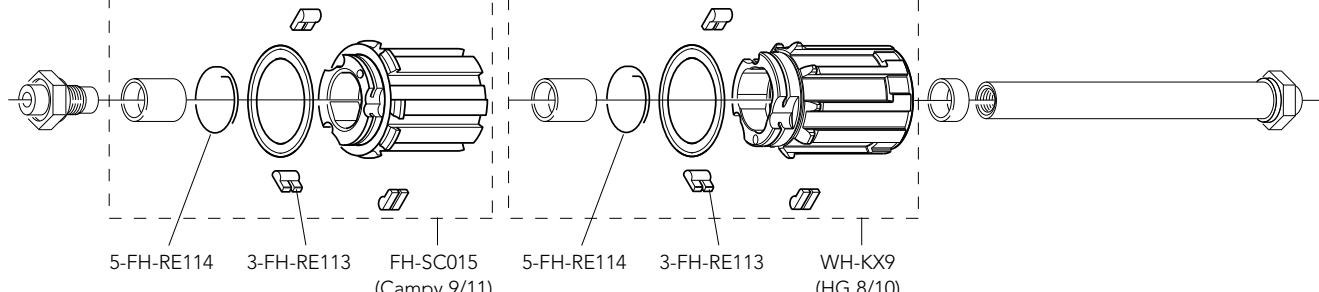
HUBS			
			
			
			
QUICK-RELEASES	QR8-40BFR	front + rear	

SPOKES			
COMPLETE FRONT KIT	KIT-23VEB	23 front spokes + 1 special spoke + 24 nipples	
COMPLETE REAR KIT	KIT-34VEB	18 rear right spokes + 8 rear left spokes + 1 rear left special spoke + 27 nipples	
MINI-KIT	KIT-700VEB	3 front spokes + 5 rear spokes + 7 nipples	
NIPLES	50-WH-NZO	50 pieces	

NOTES			

SCIROCCO™ CX clincher

CYCLOCROSS - MEDIUM PROFILE

INTENDED USE	WHEEL CODES	DESCRIPTION	WEIGHT
This product has been designed and manufactured to be fitted and used only on "racing" or "cyclocross" bikes (if they bear the CX mark), and any other use is expressly excluded. Any other use of this product (like, for instance, cross country, all mountain-enduro, acrobatic off-road, downhill, fourcross, freeride, free-style or any other type of extreme off-road cycling as defined by UCI) can cause accidents, injuries and even death and is therefore expressly forbidden	WH11-SCXCFRB	FRONT+REAR Campagnolo FW body	1.795
	WH12-SCXCFRXB	FRONT+REAR HG type FW body	1.834
	WH11-SCXCFB	front	775
	WH11-SCXCRB	rear Campagnolo FW body	1.020
	WH12-SCXCRXB	rear HG type FW body	1.059

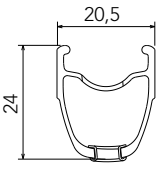
RIM			
	RIM-TAPE	2-WH-RT01 (18 mm - 2 pieces)	* These wheels are designed to mount cyclo-cross up to 35 mm tyres. We highly recommend complying with maximum pressures indicated on cyclo-cross tyres. Do no use 29" MTB tyres.
	LABEL KIT	LAB-SCXCB11 (for a pair of front+rear wheels)	
	VALVE HOLE	6,5 mm	
	DIAMETER	700C (622 x 15C)	
	TYRE SECTION	See section table and inflation pressures on page 205*	

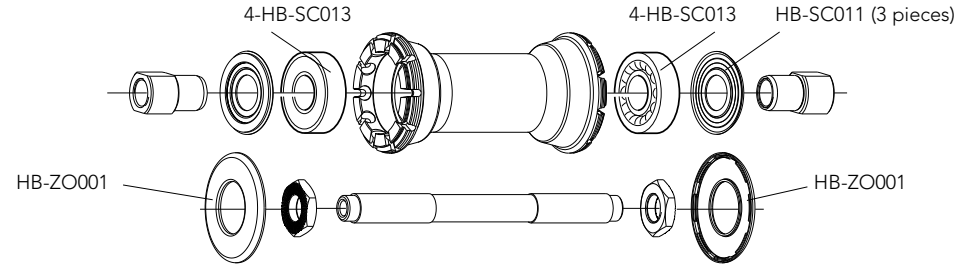
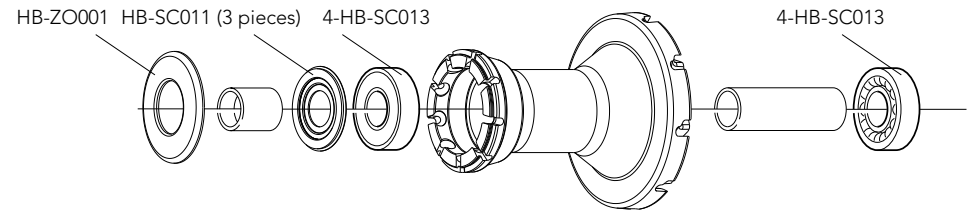
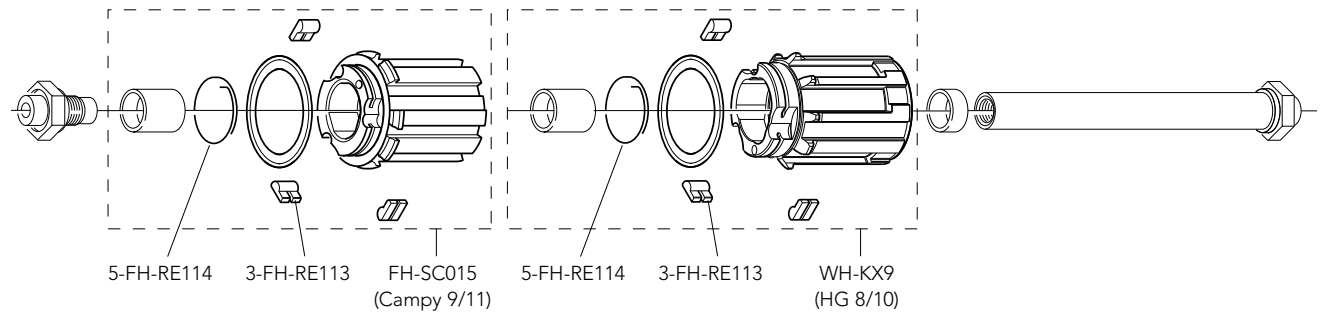
HUBS			
			
			
			
QUICK-RELEASES	QR12-ZOBFR	front + rear	

SPOKES			
COMPLETE FRONT KIT	KIT-43SCB	16 front spokes + 16 nipples	
COMPLETE REAR KIT	KIT-44SCB	14 rear right spokes + 7 rear left spokes + 21 nipples	
MINI-KIT	KIT-700SCB	2 front spokes + 2 rear right spokes + 2 rear leeft spokes + 6 nipples	
NIPLES	50-WH-NZO	50 pieces	

NOTES			

BULLET™ ULTRA CX clincher (H50)

CYCLOCROSS - HIGH PROFILE

INTENDED USE	WHEEL CODES	DESCRIPTION	WEIGHT
This product has been designed and manufactured to be fitted and used only on "racing" or "cyclocross" bikes (if they bear the CX mark), and any other use is expressly excluded. Any other use of this product (like, for instance, cross country, all mountain-enduro, acrobatic off-road, downhill, fourcross, freeride, free-style or any other type of extreme off-road cycling as defined by UCI) can cause accidents, injuries and even death and is therefore expressly forbidden	WH12-BUUXCFR	FRONT+REAR Campagnolo FW body	1.610
	WH12-BUUXCFRX	FRONT+REAR HG type FW body	1.649
	WH12-BUUXCF	front	737
	WH12-BUUXCR	rear Campagnolo FW body	873
	WH12-BUUXCRX	rear HG type FW body	912

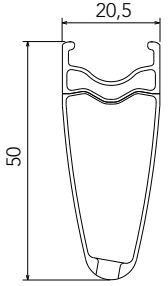
RIM			
	FRONT RIM	WH-003BUU (no labels)	<p>* These wheels are designed to mount cyclo-cross up to 35 mm tyres. We highly recommend complying with maximum pressures indicated on cyclo-cross tyres. Do no use 29" MTB tyres.</p>
	REAR RIM	WH-004BUU (no labels)	
	LABEL KIT	LAB-BUU12 (front+rear) - LAB-BUU12DK (front+rear DARK)	
	VALVE HOLE	6,5 mm	
	VALVE EXTENSION	UT-WH130M (male extension) - UT-WH130F (female extension)	
	DIAMETER	700C (622 x 15C)	
	TYRE	See section table and inflation pressures on page 205*	

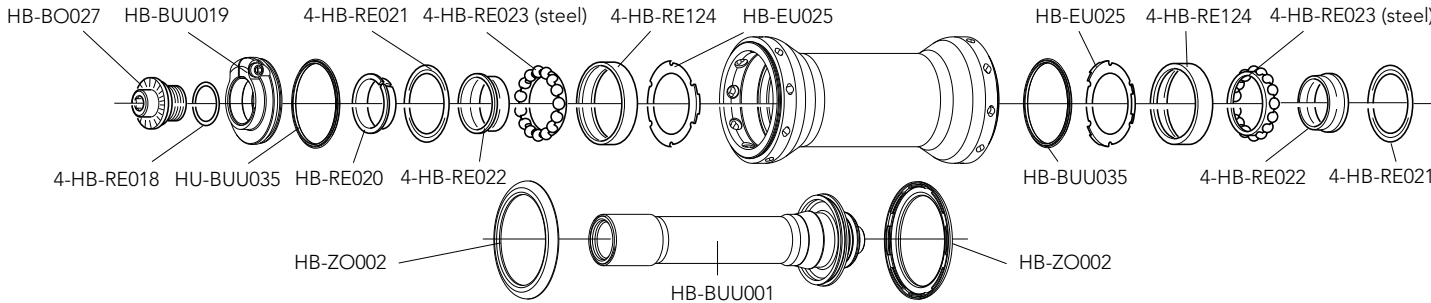
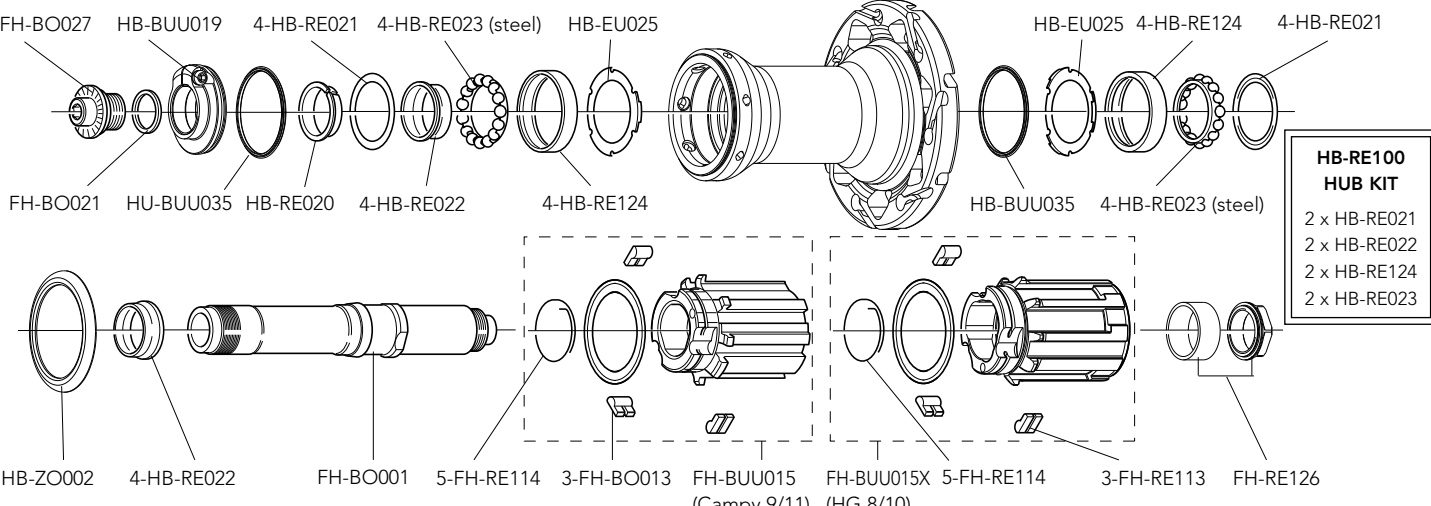
HUBS			
			
			
			<p>HB-RE100 HUB KIT</p> <ul style="list-style-type: none"> 2 x HB-RE021 2 x HB-RE022 2 x HB-RE124 2 x HB-RE023

QUICK-RELEASES	QR12-BUUBFR	front + rear
----------------	-------------	--------------

SPOKES			
COMPLETE FRONT KIT	KIT-03BUU	18 front spokes + 18 nuts + 18 nut supporting plates	
COMPLETE REAR KIT	KIT-04BUU	14 rear right spokes + 7 rear left spokes + 21 nuts + 21 nut supporting plates	
MINI-KIT	KIT-500BUU	2 front spokes + 2 rear right spokes + 2 rear left spokes + 6 nuts + 6 nut supporting plates	
NIPPLES	WH-015BUU	red - 10 pieces	
SPOKE RING	UT-WH010	anti-rotation spokes	
INSERT NIPPLE	UT-WH160	magnet-attractor for nipple	
NIPPLE MAGNET	UT-WH050	nipple-guide	
SPOKE SPANNER	UT-WH090	spoke wrenches	

NOTES			

BORA™ ONE CX tubular

CYCLOCROSS - HIGH PROFILE

INTENDED USE	WHEEL CODES	DESCRIPTION	WEIGHT
This product has been designed and manufactured to be fitted and used only on "racing" or "cyclocross" bikes (if they bear the CX mark), and any other use is expressly excluded. Any other use of this product (like, for instance, cross country, all mountain-enduro, acrobatic off-road, downhill, fourcross, freeride, free-style or any other type of extreme off-road cycling as defined by UCI) can cause accidents, injuries and even death and is therefore expressly forbidden	WH12-BOXTFR1	FRONT+REAR Campagnolo FW body+brake shoes BR-BO500	1.350
	WH12-BOXTFRX1	FRONT+REAR HG type FW body+brake shoes BR-BO500X	1.389
	WH12-BOXTF1	front+brake shoes BR-BO500	590
	WH12-BOXTFX1	front+brake shoes BR-BO500X	590
	WH12-BOXTR1	rear Campagnolo FW body+brake shoes BR-BO500	760
	WH12-BOXTRX1	rear HG type FW body+brake shoes BR-BO500X	799

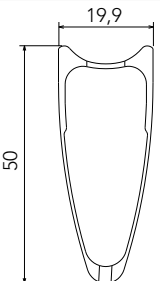
RIM	
	<p>FRONT RIM REAR RIM LABEL KIT VALVE HOLE VALVE EXTENSION DIAMETER TYRE BRAKE SHOES</p> <p>WH-001BO1 (with labels) WH-002BO1 (with labels) LAB-BO1T10 (front+rear) 6,5 mm UT-HU130 634 mm See recommended tyre manufacturer inflation pressure for carbon rims - BR-BO500 (per Campagnolo brakes) - BR-BO500X (per Shimano brakes)</p>

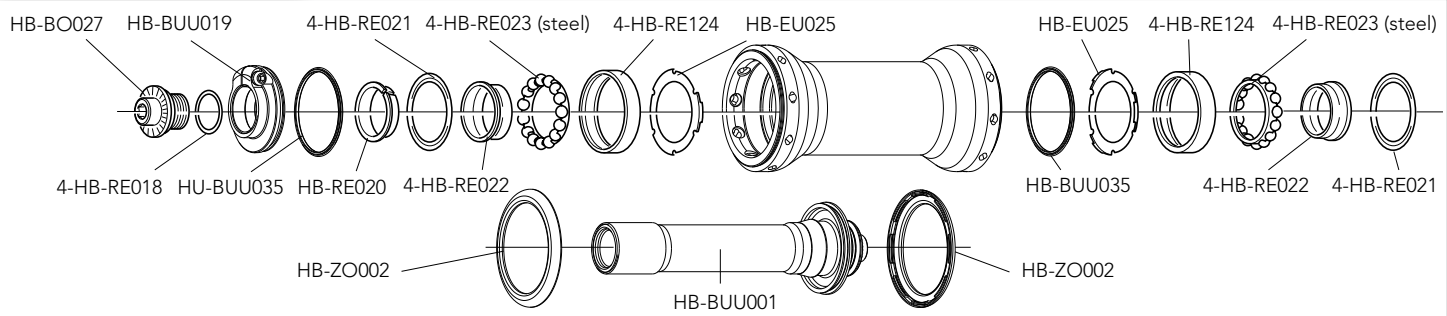
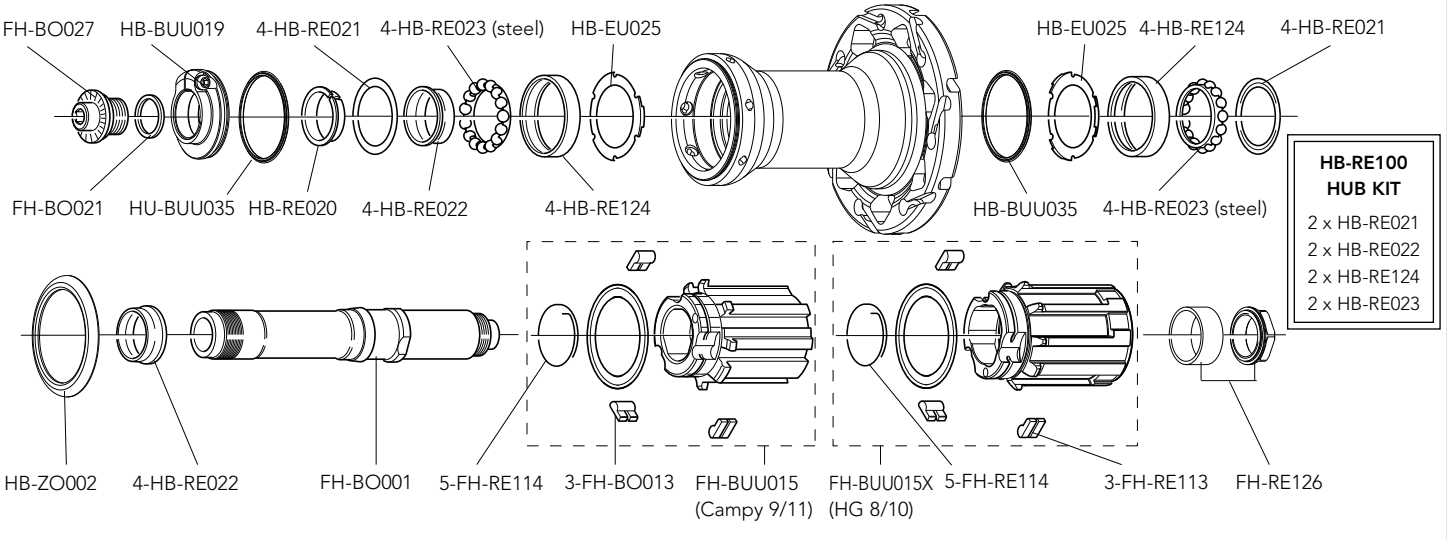
HUBS	
	
 <div style="border: 1px solid black; padding: 5px; width: fit-content; margin-top: 10px;"> <p>HB-RE100 HUB KIT 2 x HB-RE021 2 x HB-RE022 2 x HB-RE124 2 x HB-RE023</p> </div>	
QUICK-RELEASES	QR12-BUUBFR front + rear

SPOKES		
COMPLETE FRONT KIT	KIT-01BO1	18 front spokes + 18 nuts + 18 nut supporting plates
COMPLETE REAR KIT	KIT-02BO1	14 rear right spokes + 7 rear left spokes + 21 nuts + 21 nut supporting plates
MINI-KIT	KIT-100BO1	2 front spokes + 2 rear right spokes + 2 rear left spokes + 6 nuts + 6 nut supporting plates
NUTS	10-WH-010BO	10 pieces
PIASTRINE	10-WH-011BO	10 pieces

! WARNING!

Because of the high temperatures reached when braking, we recommend you use only glue for tubular tires specifically for carbon fibre rims.

MAXIMUM OPERATING PRESSURE

			RIM DIMENSION			
			13C		15C	
			mm	in.	BAR	PSI
TYRE WIDTH	18	0,70	10,0	146		
	20	0,80	9,5	138		
	23	0,90	9,5	138	9,5	138
	25	1,00	9,0	131	9,0	131
	28	1,10			8,0	117
	30	1,20			7,0	103
	32	1,25			6,7	99
	35	1,30			6,3	93

RECORD™
HS7-RE

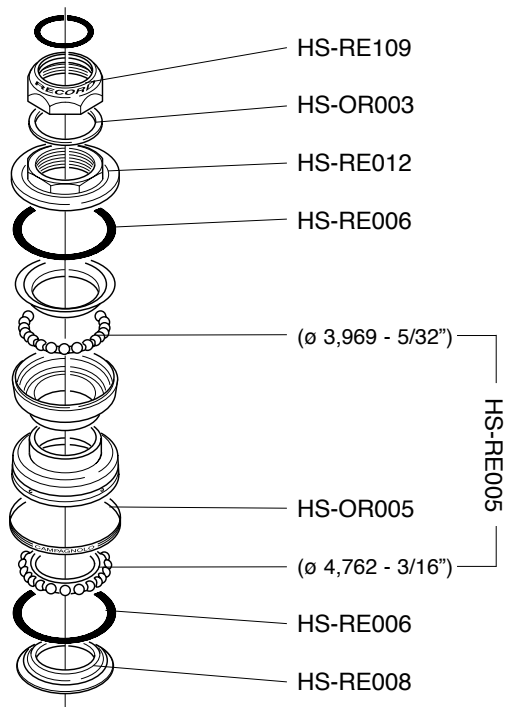

RECORD™
Hiddenset™
 1 1/8": HS03-REHIOS

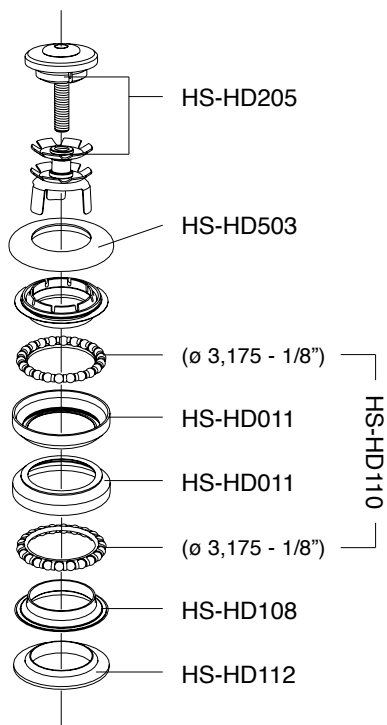

RECORD™
Hiddenset™ TTC™
 1 1/8": HS03-REHIOST

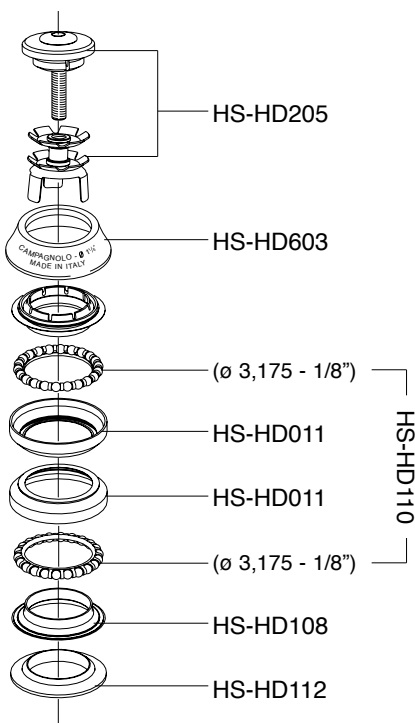

RECORD™ Threadless™
 1": HS00-RETH

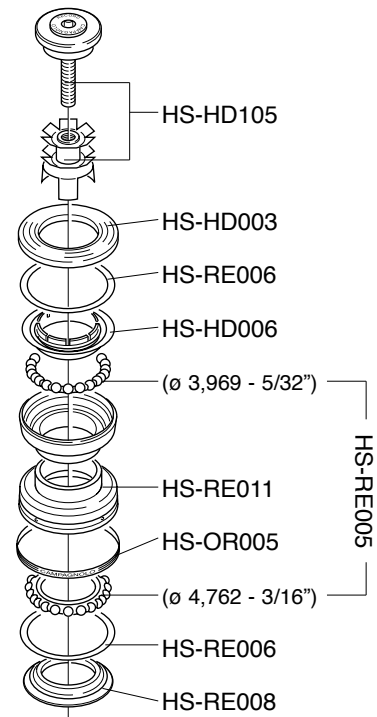

RECORD™ PISTA™

111 mm

BB01-REPIIT

BB01-REPIBC

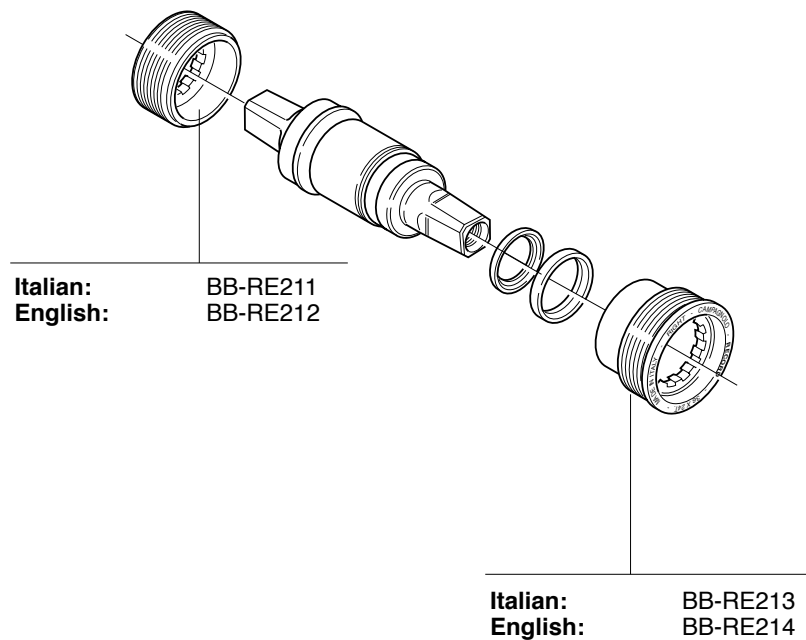

SUPER RECORD™
ULTRA-TORQUE™ Carbon 11s
FC11-SR...C

FC-SR200
KIT VITI / SCREWS&NUTS
 4 AA + 1 AB + 1 AC

FC-SR007
(ONLY for Titanium version)
FC-RE007
(ONLY for steel version)

		TITANIUM AXLE	STEEL AXLE
B	170 mm	FC-SR601	FC-SR811
	172,5 mm	FC-SR603	FC-SR813
	175 mm	FC-SR605	FC-SR815
C	Z39	FC-SR139*	
	Z42	FC-SR042*	
D	Z52 for 39	FC-SR152*	
	Z53 for 39	FC-SR153*	
	Z54 for 42	FC-SR054*	
	Z55 for 42	FC-SR055*	
Z39 + Z52 + FC-SR200		FC-SR092	
Z39 + Z53 + FC-SR200		FC-SR093	

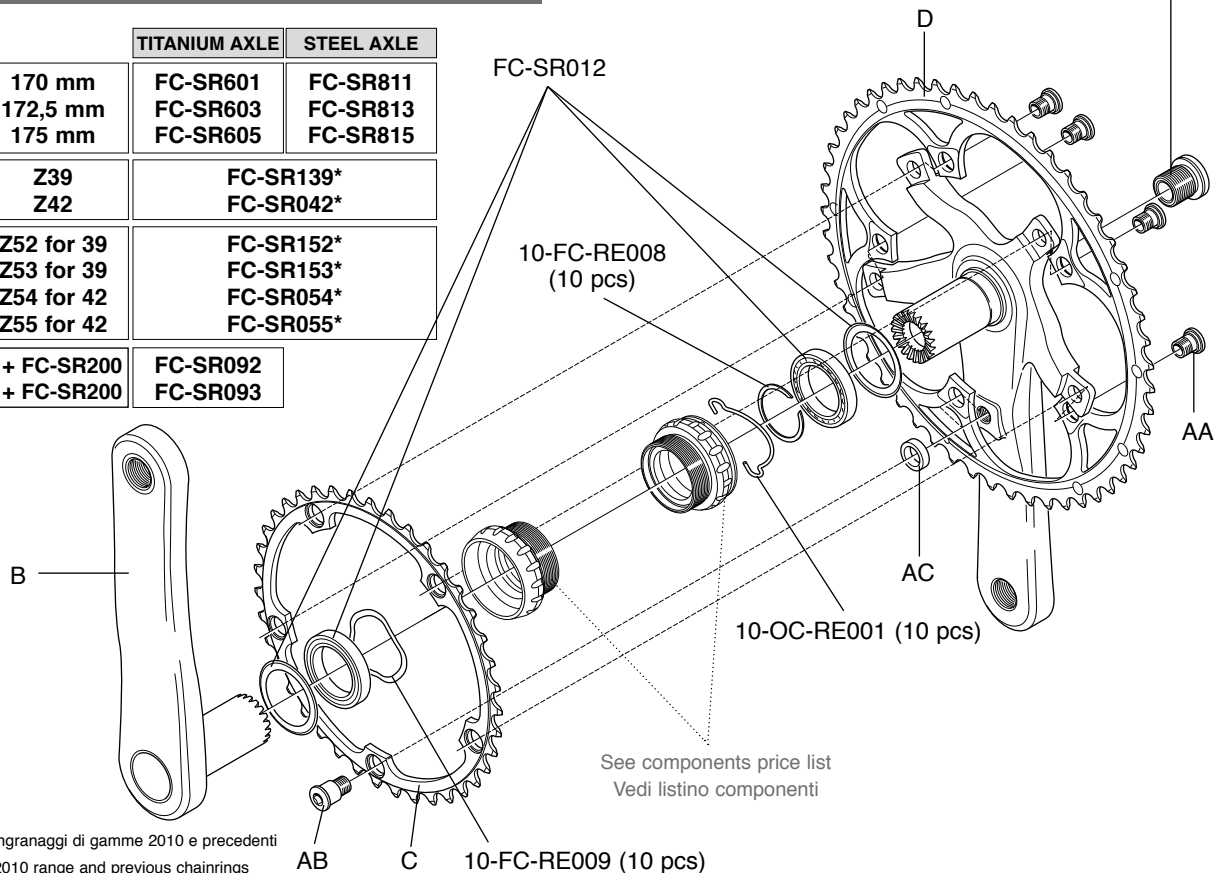

* non compatibili con ingranaggi di gamme 2010 e precedenti

* not compatible with 2010 range and previous chainrings

SUPER RECORD™
ULTRA-TORQUE™ CT™ Carbon 11s
FC11-SR...C

FC-SR200
KIT VITI / SCREWS&NUTS

4 AA + 1 AB + 1 AC

FC-SR007
(ONLY for Titanium version)
 FC-RE007
(ONLY for steel version)

		TITANIUM AXLE	STEEL AXLE
B	170 mm	FC-SR601	FC-SR811
	172,5 mm	FC-SR603	FC-SR813
	175 mm	FC-SR605	FC-SR815
C	Z34	FC-SR134*	
D	Z50 for 34	FC-SR150*	

* non compatibili con ingranaggi di gamme precedenti
 * not compatible with previous ranges chainrings

Z34 + Z50 + FC-SR200	FC-SR040
----------------------	----------

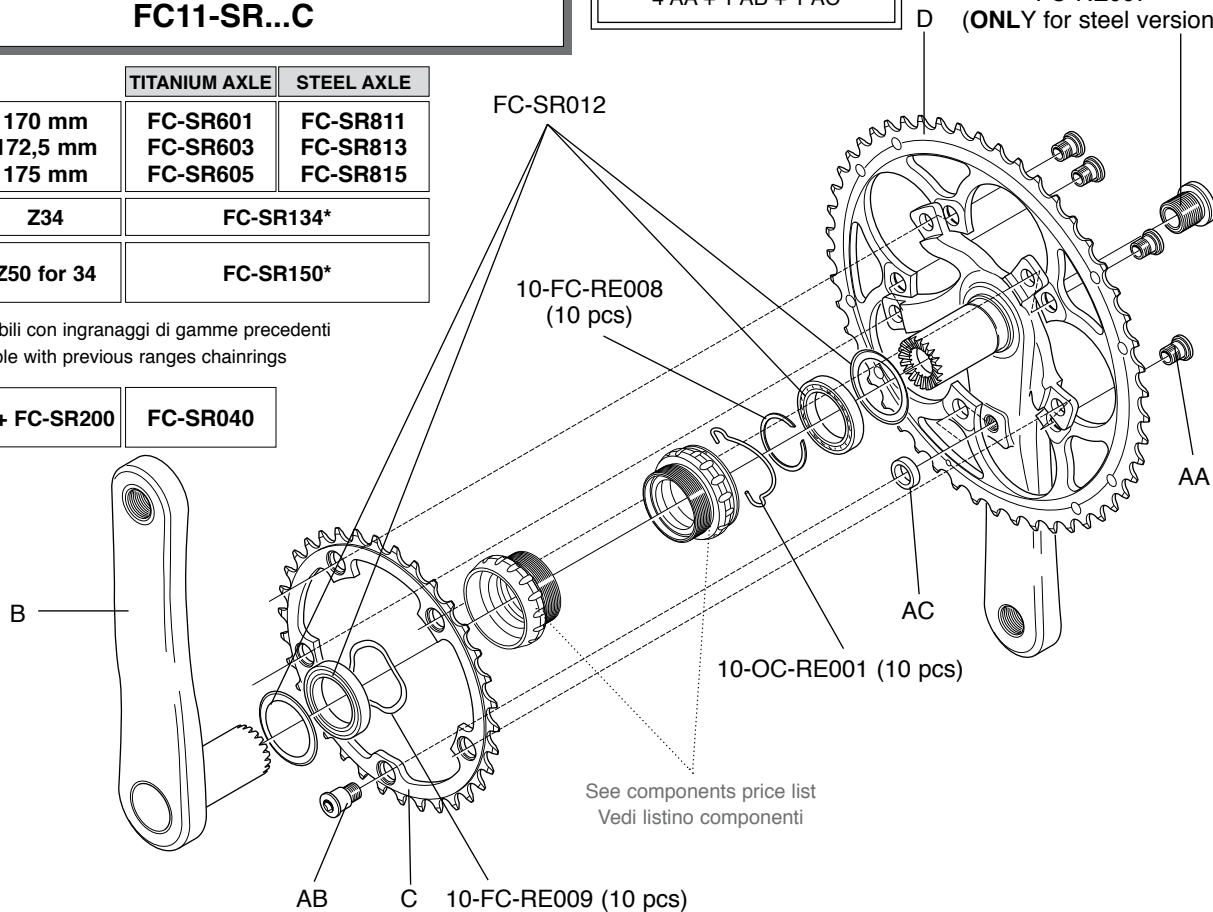

RECORD™ ULTRA-TORQUE™

Carbon 11s FC11-RE...C

FC-SR200 KIT VITI / SCREWS&NUTS

4 AA + 1 AB + 1 AC

B	170 mm	FC-RE731
	172,5 mm	FC-RE733
	175 mm	FC-RE735
C	Z39	FC-SR139*
	Z42	FC-SR042*
D	Z52 for 39	FC-SR152*
	Z53 for 39	FC-SR153*
	Z54 for 42	FC-SR054*
	Z55 for 42	FC-SR055*
Z39 + Z52 + FC-SR200		FC-SR092
Z39 + Z53 + FC-SR200		FC-SR093

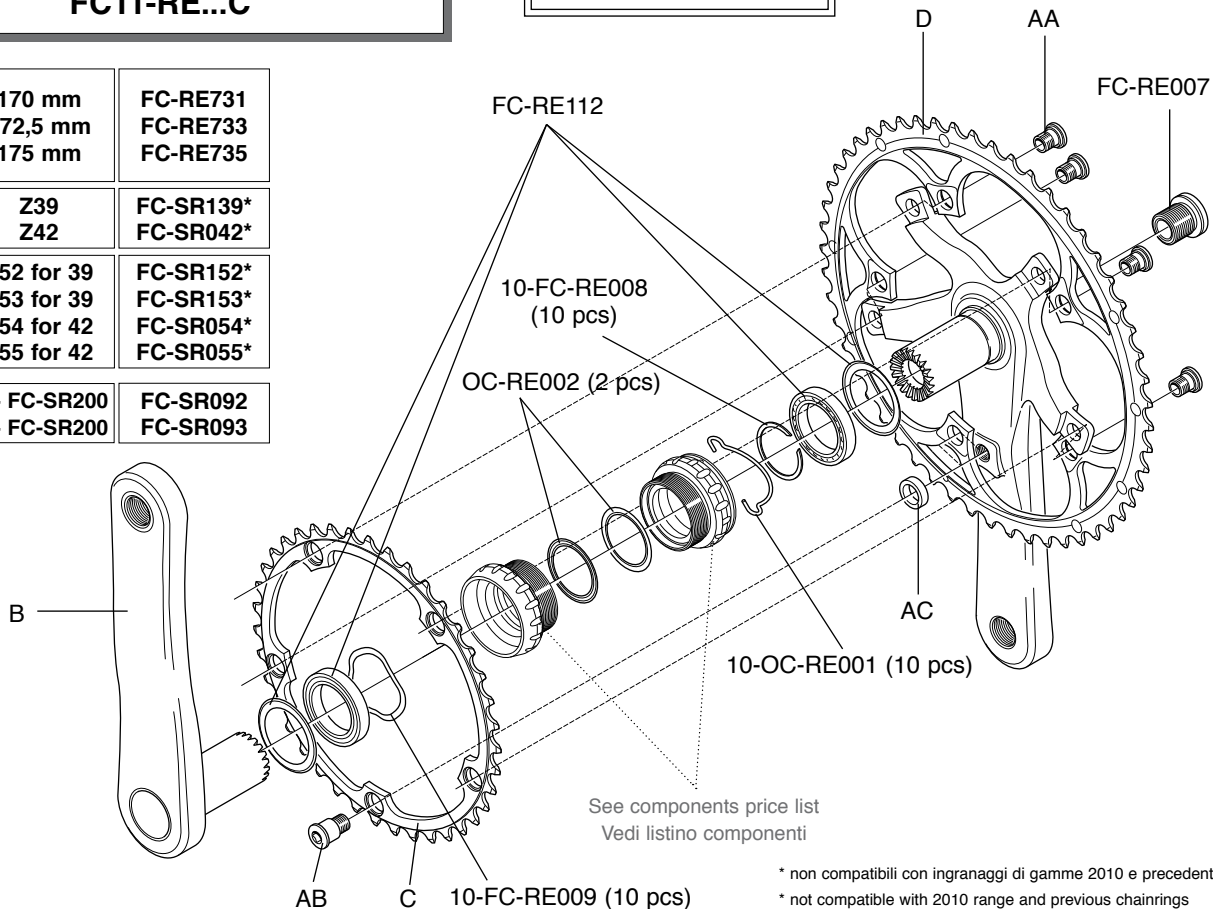

* non compatibili con ingranaggi di gamme 2010 e precedenti

* not compatible with 2010 range and previous chainrings

RECORD™ ULTRA-TORQUE™
CT™ Carbon 11s
FC11-RE...C

FC-SR200
KIT VITI / SCREWS&NUTS

4 AA + 4 AB + 1 AC

B	170 mm 172,5 mm 175 mm	FC-RE731 FC-RE733 FC-RE735
C	Z34	FC-SR134*
D	Z50 for 34	FC-SR150*

* non compatibili con ingranaggi di gamme precedenti
 * not compatible with previous ranges chainrings

Z34 + Z50 + FC-SR200 **FC-SR040**

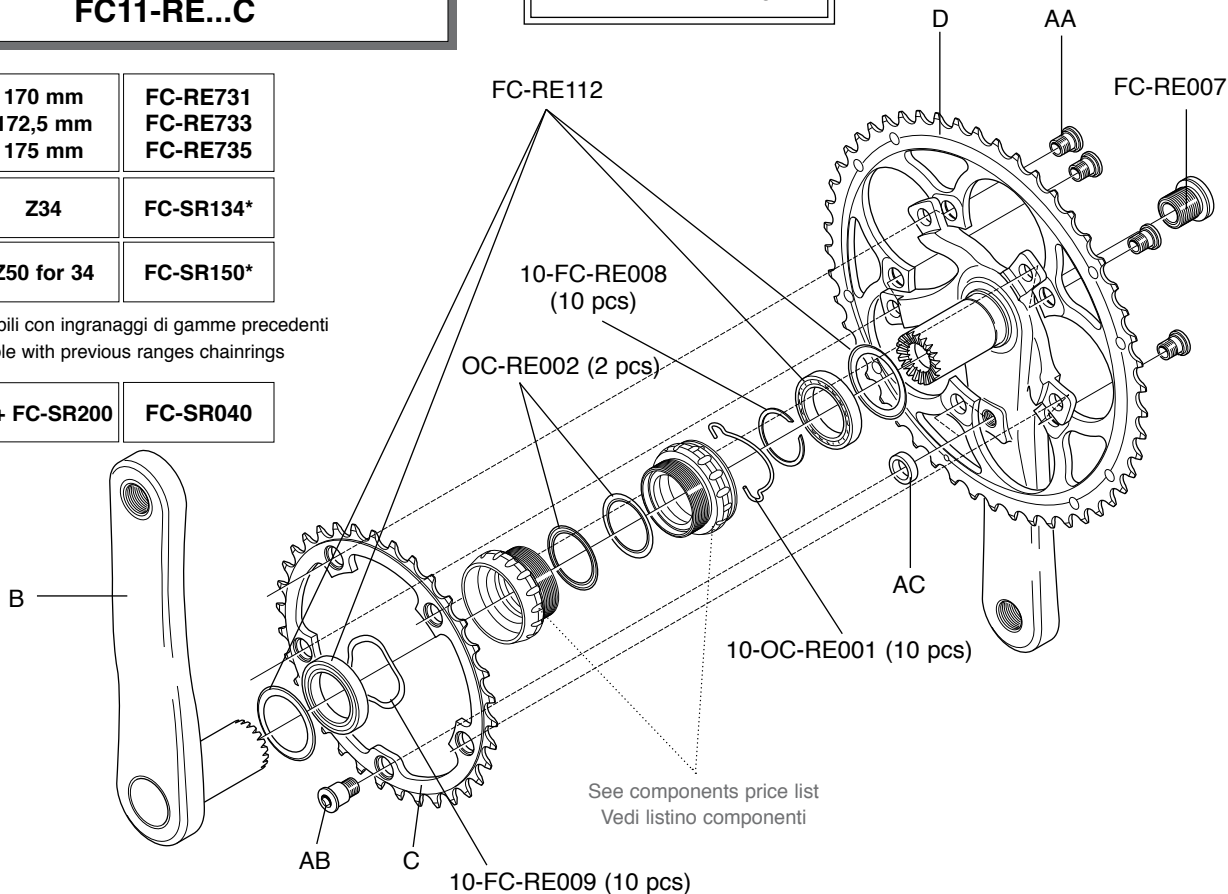

RECORD™
PISTA™
FC01-REPL...

FC-PI100
KIT VITI / SCREWS&NUTS

5 U + 5 V

B	165 mm	FC-PI465
	170 mm	FC-PI470

C	Z47	FC-PI047
	Z48	FC-PI048
	Z49	FC-PI049
	Z50	FC-PI050
	Z51	FC-PI051
	Z52	FC-PI052

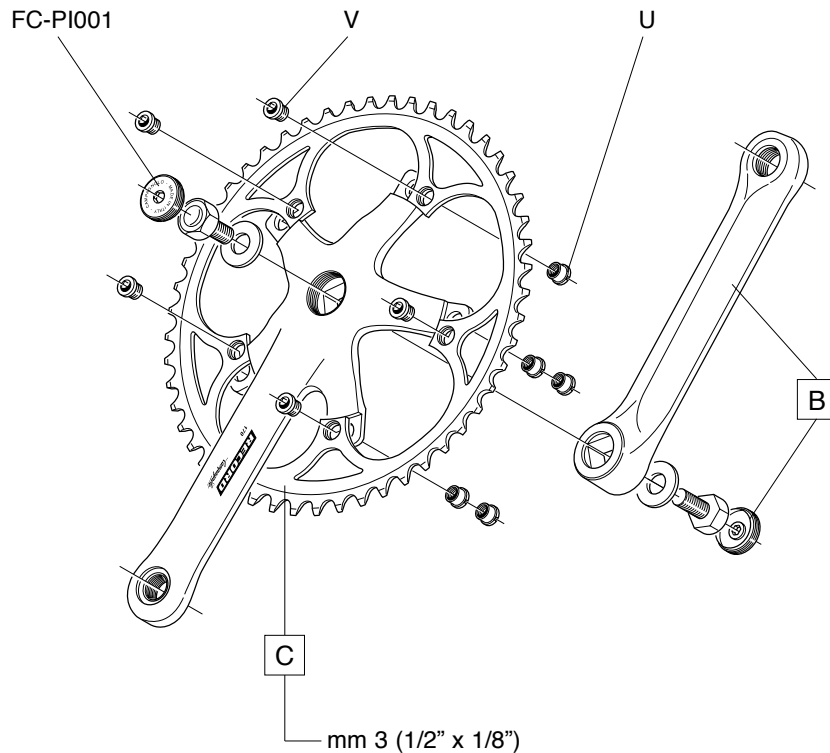

CHORUS™ ULTRA-TORQUE™

Carbon 11s FC11-CH...C

FC-SR200 KIT VITI / SCREWS&NUTS

4 AA + 1 AB + 1 AC

B	170 mm	FC-CH751
	172,5 mm	FC-CH753
	175 mm	FC-CH755
C	Z39	FC-SR139*
	Z42	FC-SR042*
D	Z52 for 39	FC-SR152*
	Z53 for 39	FC-SR153*
	Z54 for 42	FC-SR054*
	Z55 for 42	FC-SR055*

Z39 + Z52 + FC-SR200	FC-SR092
Z39 + Z53 + FC-SR200	FC-SR093

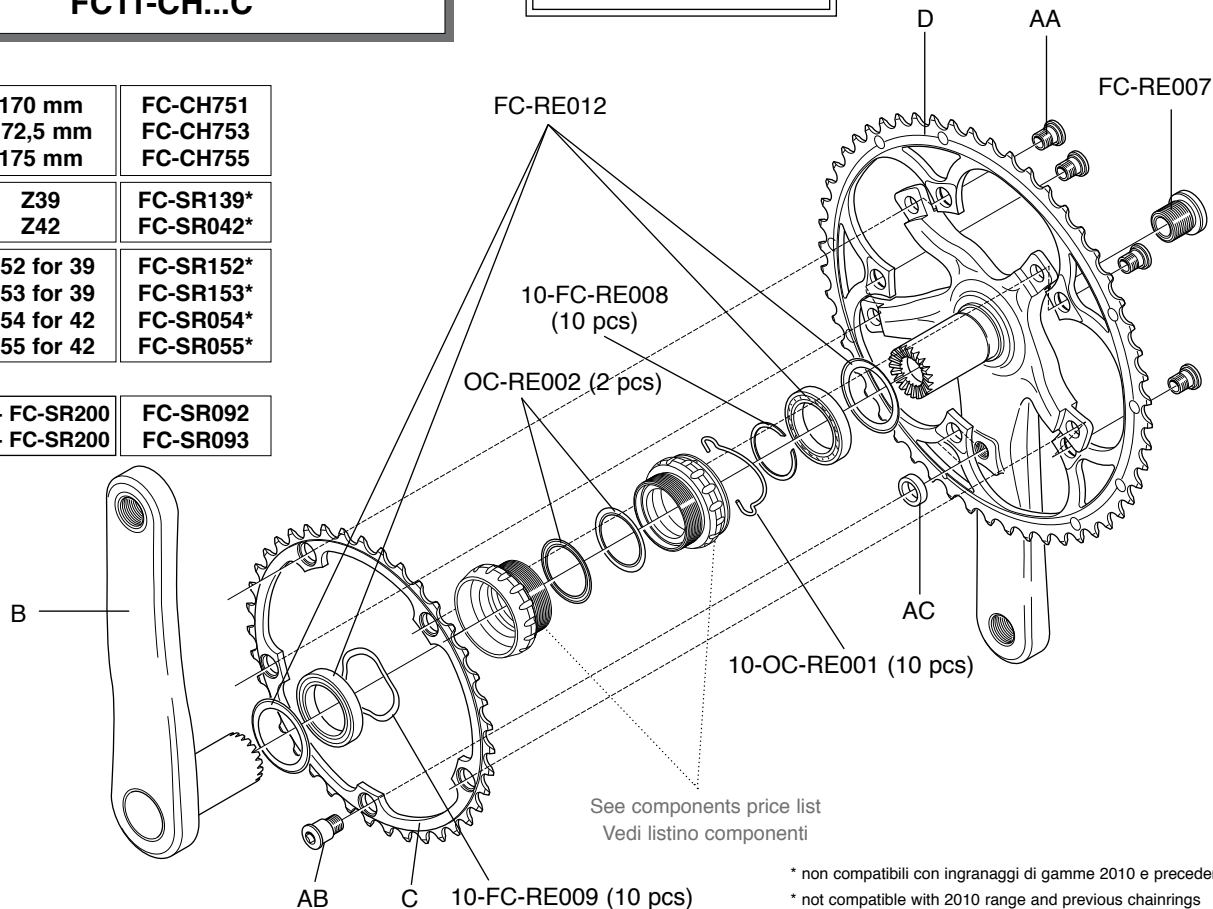

* non compatibili con ingranaggi di gamme 2010 e precedenti

* not compatible with 2010 range and previous chainrings

CHORUS™ ULTRA-TORQUE™
CT™ Carbon 11s
FC11-CH...C

FC-SR200
KIT VITI / SCREWS&NUTS
 4 AA + 1 AB + 1 AC

B	170 mm	FC-CH751
	172,5 mm	FC-CH753
	175 mm	FC-CH755
C	Z34	FC-SR134*
D	Z50 for 34	FC-SR150*

* non compatibili con ingranaggi di gamme precedenti
 * not compatible with previous ranges chainrings

Z34 + Z50 + FC-SR200	FC-SR040
-----------------------------	-----------------

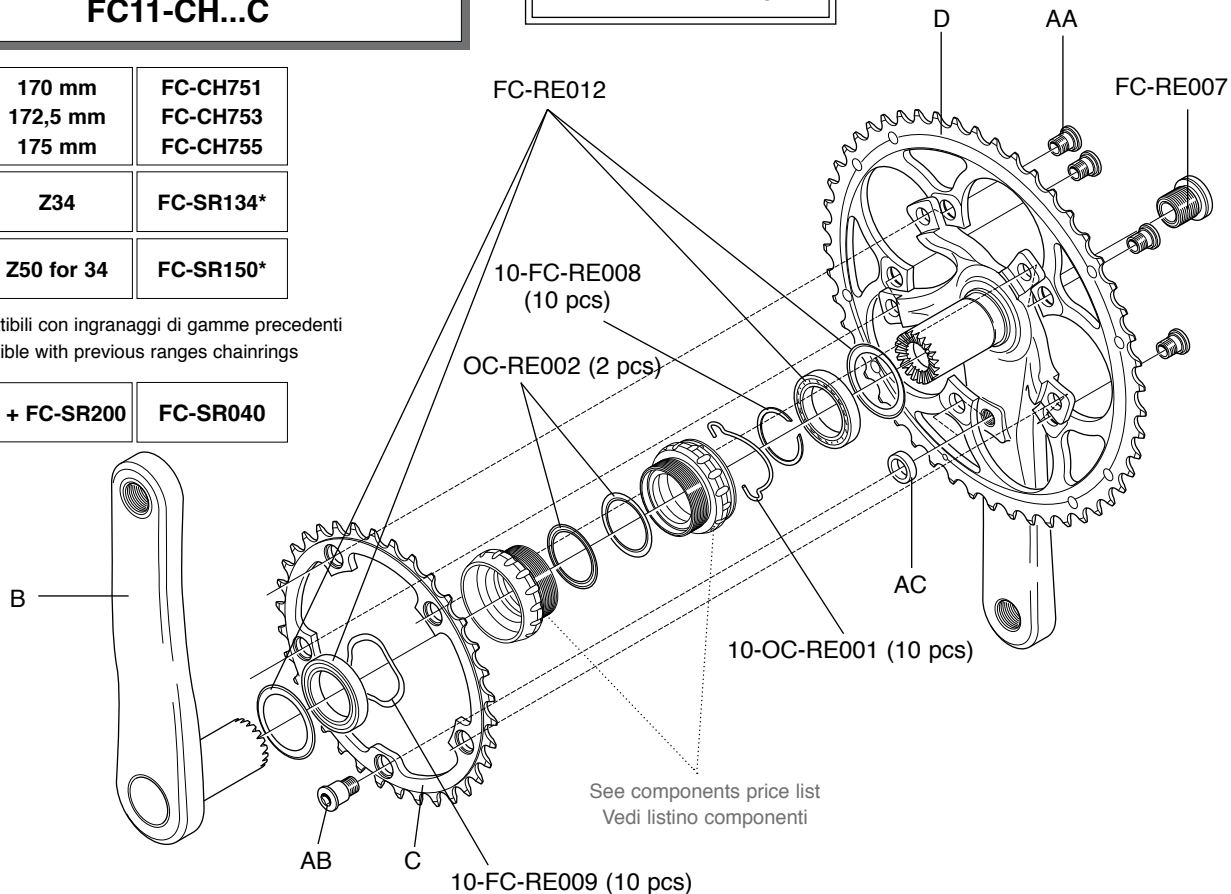

ULTRA-TORQUE™
Carbon 11s
FC12-16..C

FC-SR200
KIT VITI / SCREWS&NUTS
 4 AA + 1 AB + 1 AC

B	165 mm	FC-11165C
----------	--------	-----------

C	Z39	FC-SR139*
	Z42	FC-SR042*

D	Z52 for 39	FC-SR152*
	Z53 for 39	FC-SR153*
	Z54 for 42	FC-SR054*
	Z55 for 42	FC-SR055*

Z39 + Z52 + FC-SR200	FC-SR092
Z39 + Z53 + FC-SR200	FC-SR093

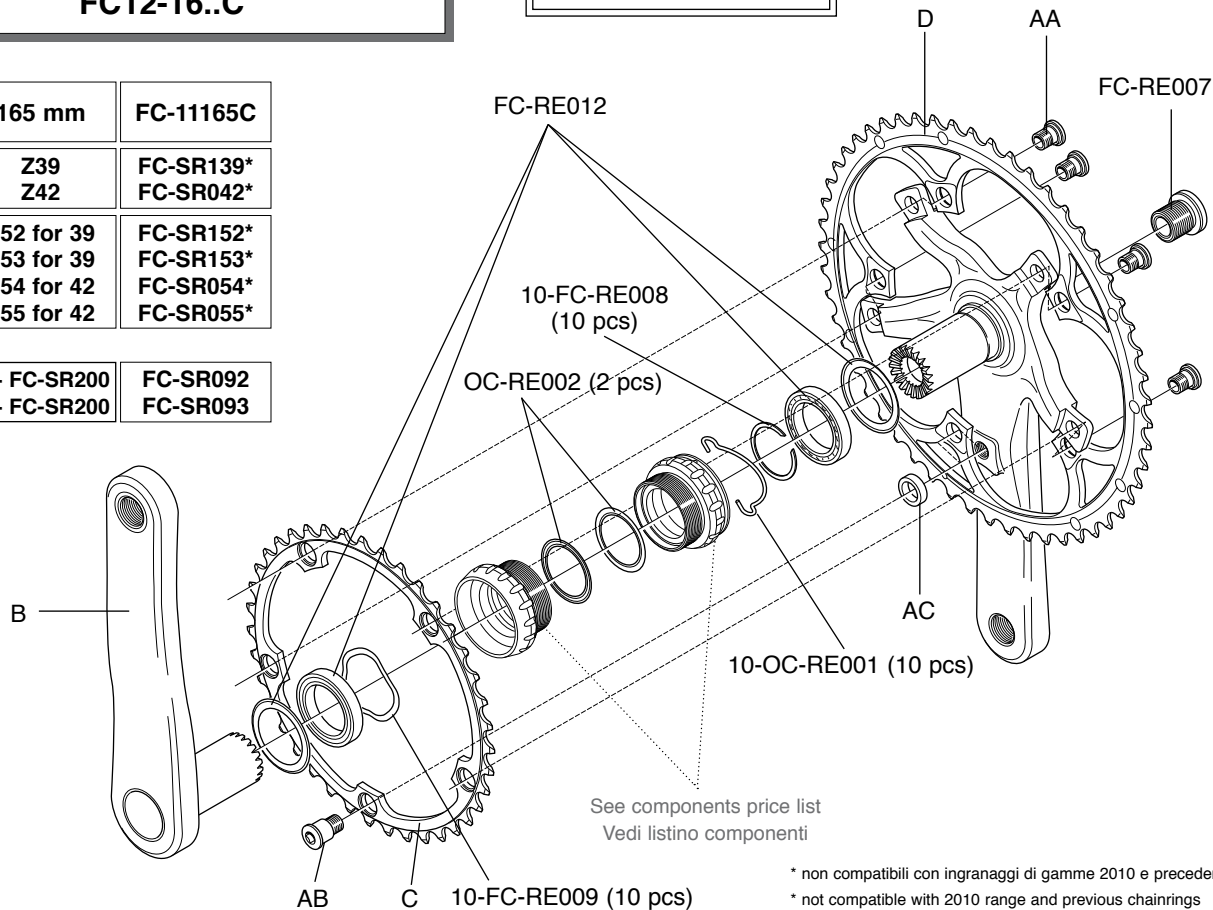

* non compatibili con ingranaggi di gamme 2010 e precedenti

* not compatible with 2010 range and previous chainrings

ULTRA-TORQUE™ CT™
Carbon 11s
FC12-1640C

FC-SR200
KIT VITI / SCREWS&NUTS
 4 AA + 1 AB + 1 AC

B	165 mm	FC-11165C
C	Z34	FC-SR134*
D	Z50 for 34	FC-SR150*

* non compatibili con ingranaggi di gamme precedenti
 * not compatible with previous ranges chainrings

Z34 + Z50 + FC-SR200	FC-SR040
-----------------------------	-----------------

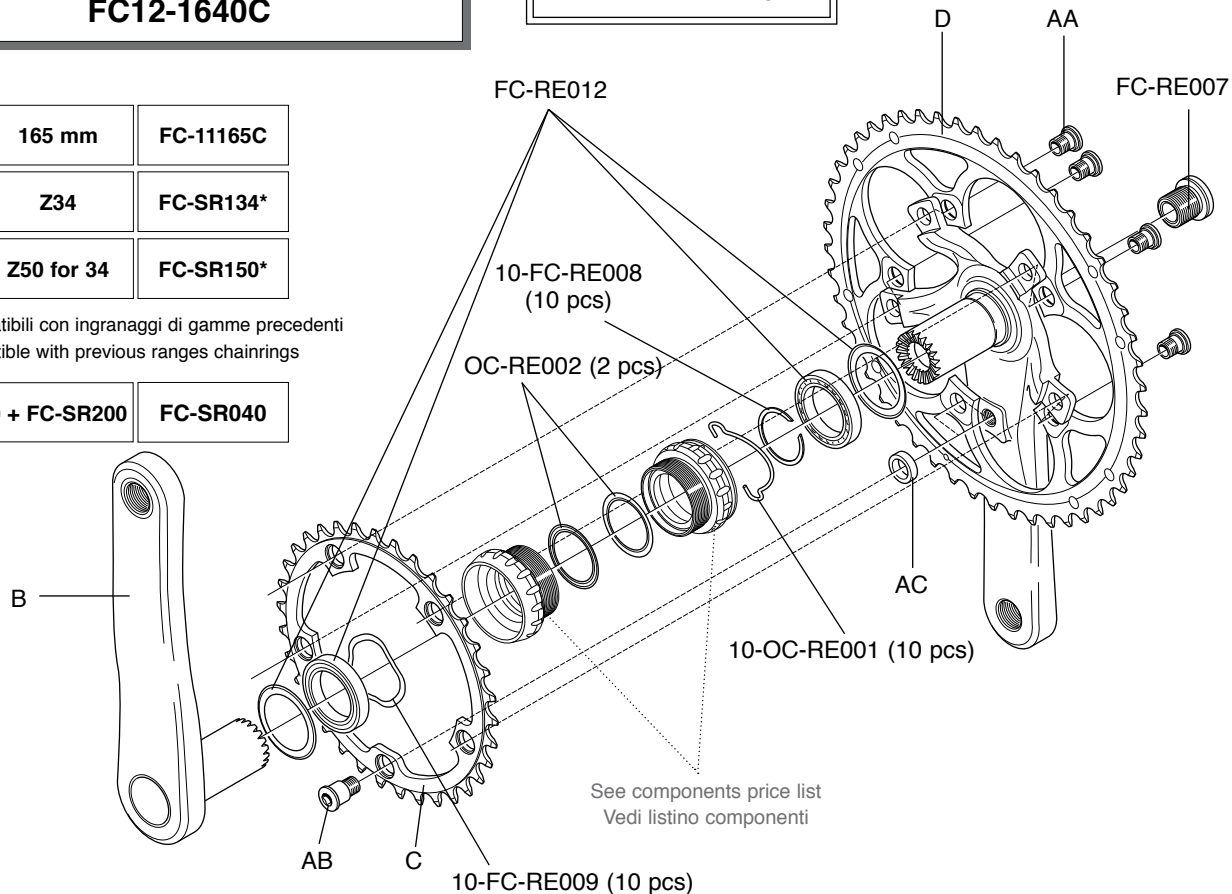

ATHENA™ POWER-TORQUE™

Carbon 11s FC11-AT...C

FC-AT300

KIT VITI / SCREWS&NUTS

4 DA + 4 DB + 1 DC + 1 DD

B	165 mm	FC-AT165C
	170 mm	FC-AT763
	172,5 mm	FC-AT765
	175 mm	FC-AT767
C	Z39	FC-AT139
D	Z52 for 39	FC-AT652
	Z53 for 39	FC-AT653

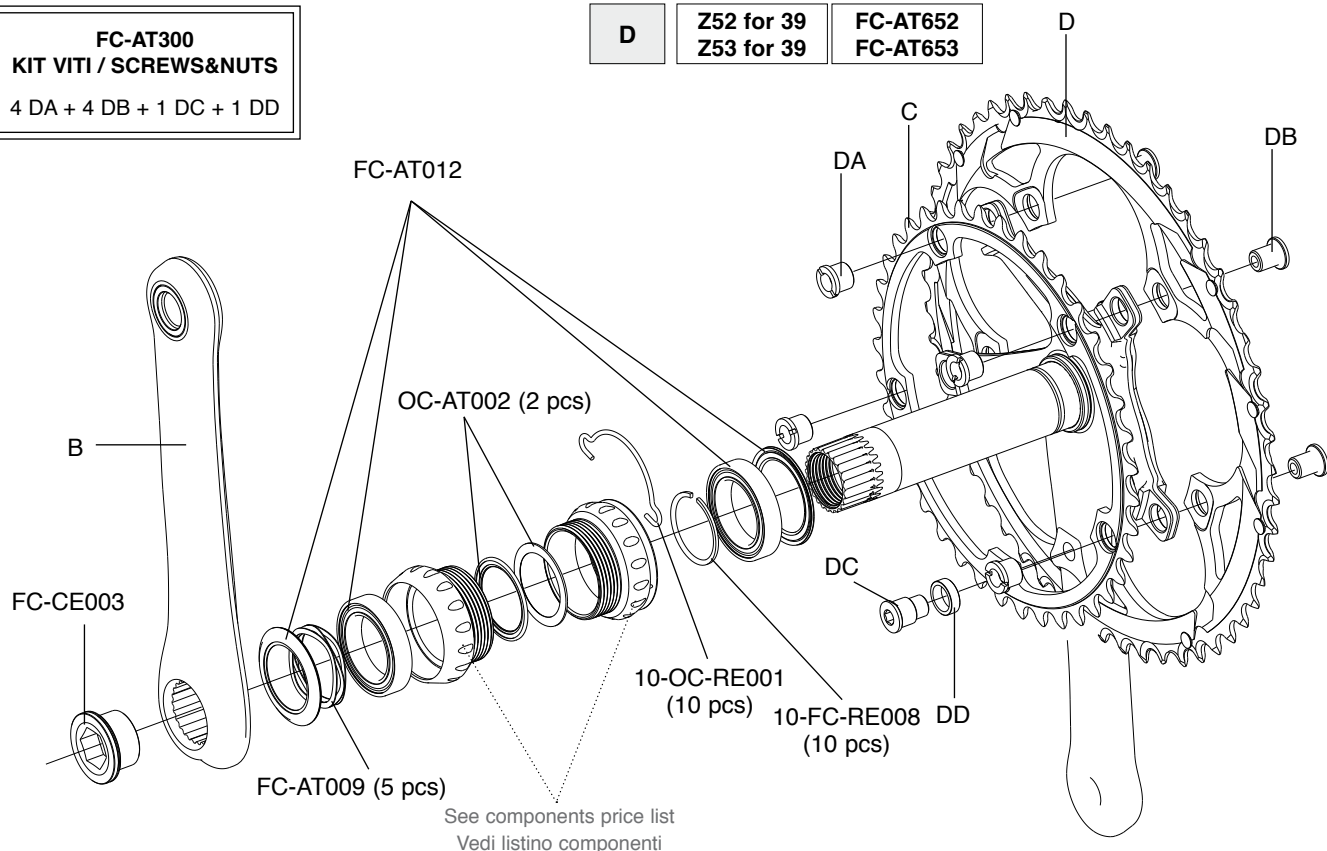

ATHENA™ POWER-TORQUE™
CT™ Carbon 11s
FC11-AT...C

FC-AT300
KIT VITI / SCREWS&NUTS
 4 DA + 4 DB + 1 DC + 1 DD

B	165mm	FC-AT165C
	170 mm	FC-AT763
	172,5 mm	FC-AT765
	175 mm	FC-AT767
C	Z34	FC-AT134
D	Z50 for 34	FC-AT250

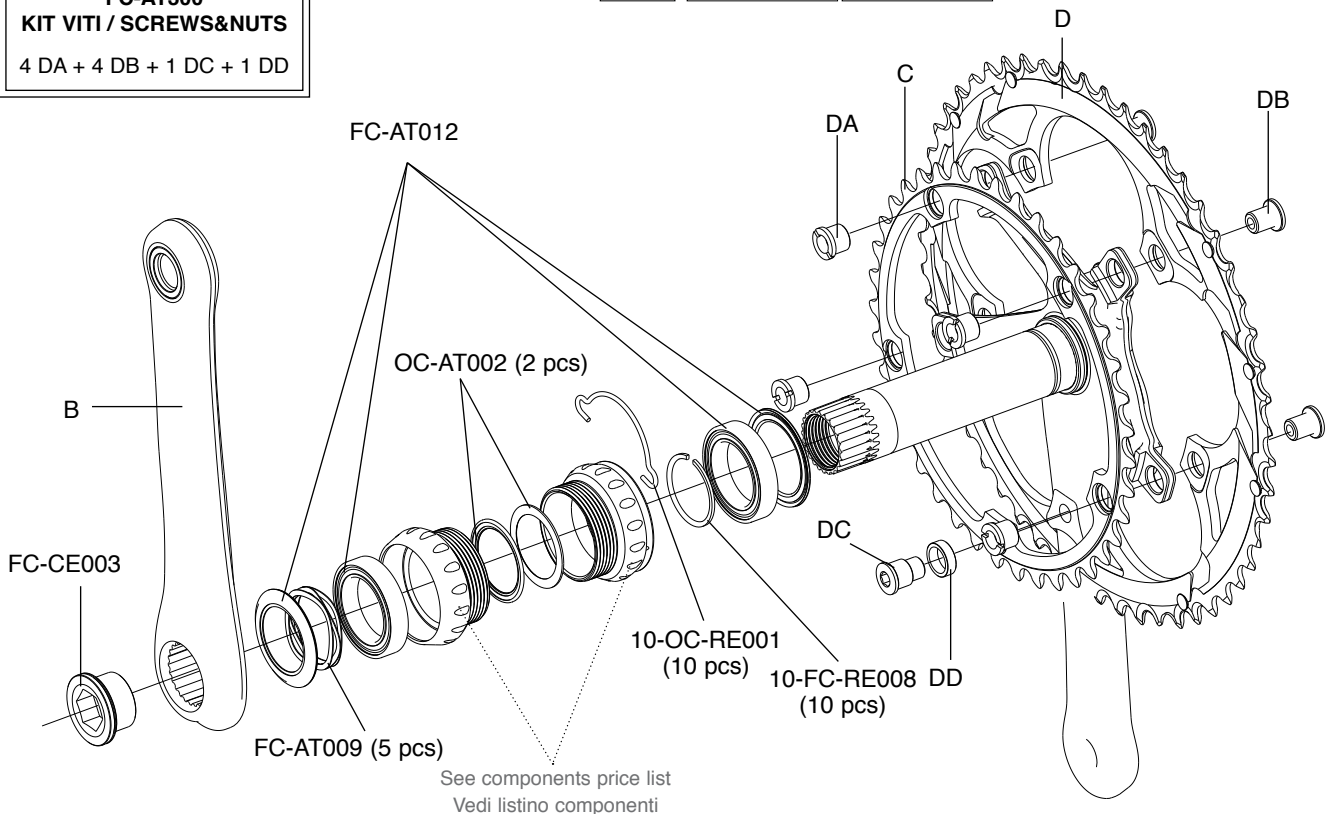

ATHENA™ POWER-TORQUE™

11s

FC11-AT... / FC12-ATB...

FC-AT200 (SILVER) - FC-AT200B (BLACK)
KIT VITI / SCREWS&NUTS

4 DA + 4 DB + 1 DC + 1 DD

		SILVER	BLACK
B	170 mm	FC-AT935	FC-ATB170
	172,5 mm	FC-AT937	FC-ATB172
	175 mm	FC-AT939	FC-ATB175
C	Z39	FC-AT239	FC-AT139
D	Z52 for 39	FC-AT752	FC-AT652
	Z53 for 39	FC-AT353	FC-AT653

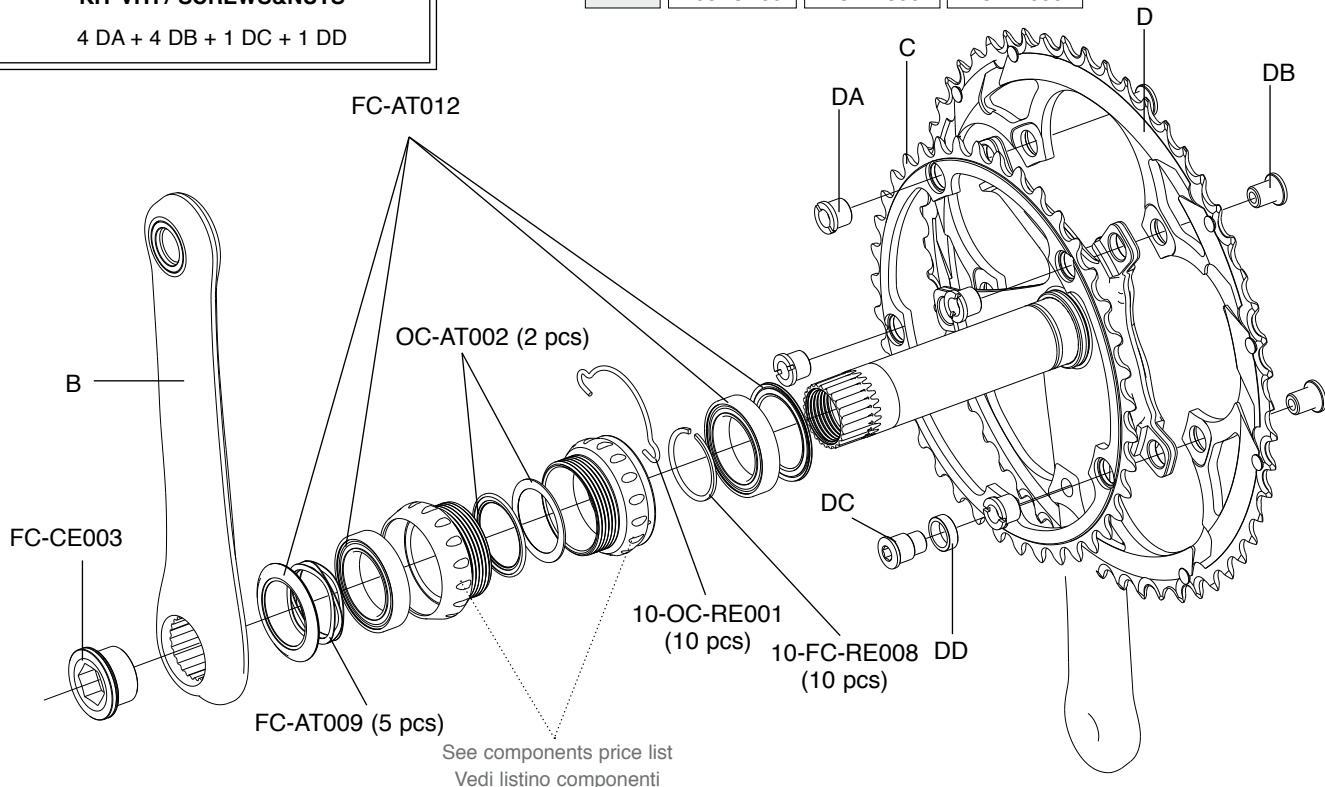

See components price list
Vedi listino componenti

ATHENA™ POWER-TORQUE™
CT™ 11s
FC11-AT... / FC12-ATB...

FC-AT200 (SILVER) - FC-AT200B (BLACK)
KIT VITI / SCREWS&NUTS

4 DA + 4 DB + 1 DC + 1 DD

SILVER

BLACK

B

170 mm
172,5 mm
175 mm

FC-AT935
FC-AT937
FC-AT939

FC-ATB170
FC-ATB172
FC-ATB175

C

Z34

FC-AT234

D

Z50 for 34

FC-AT350

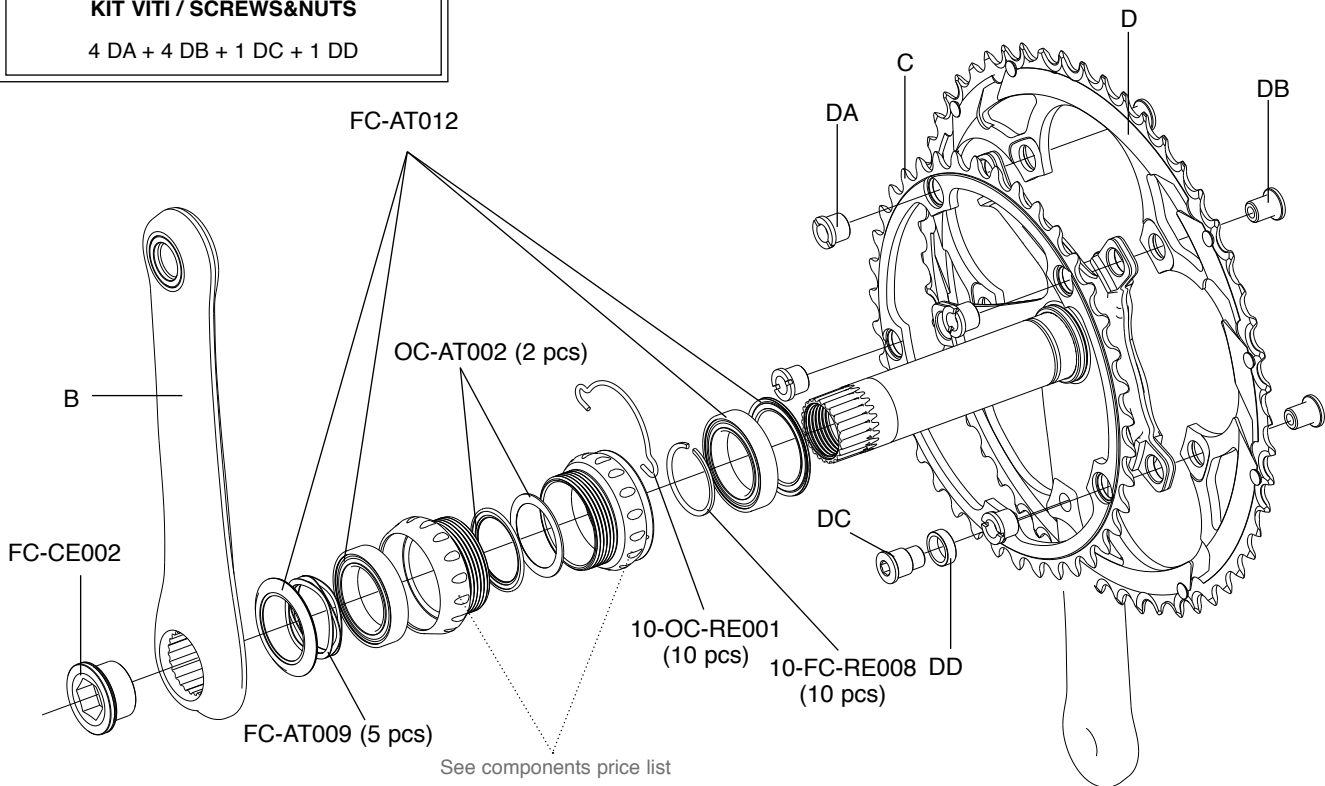

See components price list
 Vedi listino componenti

CENTAUR™ POWER-TORQUE™
Carbon 10s
FC11-CE...C

FC-AT300 (BLACK) / FC-CE200R (BLACK&RED)
KIT VITI / SCREWS&NUTS

4 DA + 4 DB + 1 DC + 1 DD

		BLACK	BLACK & RED
B	165mm	FC-CE165C	FC-CERB165C
	170 mm	FC-CE775	FC-CERB170C
	172,5 mm	FC-CE777	FC-CERB172C
	175 mm	FC-CE779	FC-CERB175C
C	Z39	FC-CE239	
D	Z52 for 39	FC-CE452	
	Z53 for 39	FC-CE453	

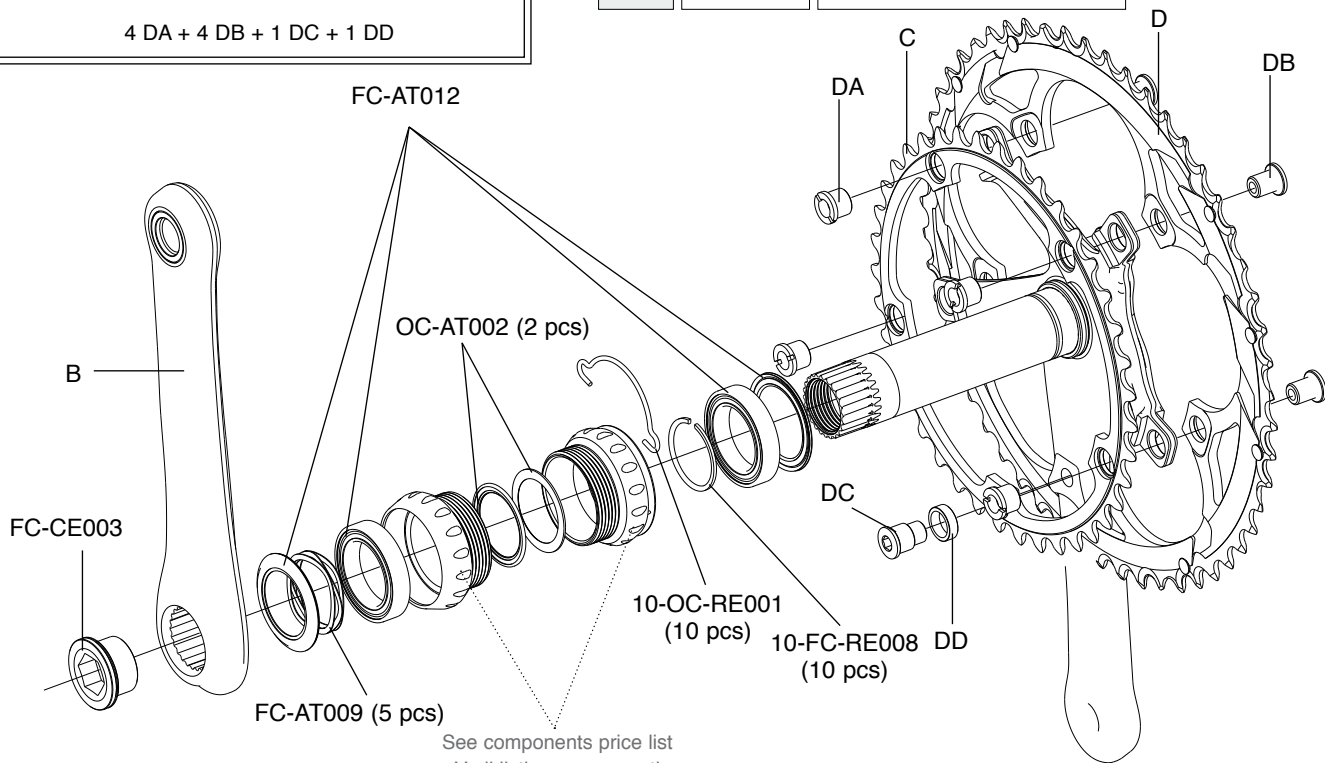

See components price list
 Vedi listino componenti

CENTAUR™ POWER-TORQUE™
CT™ Carbon 10s
FC11-CE...C

FC-AT300 (BLACK) / FC-CE200R (BLACK&RED)
KIT VITI / SCREWS&NUTS

4 DA + 4 DB + 1 DC + 1 DD

		BLACK	BLACK & RED
B	165mm	FC-CE165C	FC-CERB165C
	170 mm	FC-CE775	FC-CERB170C
	172,5 mm	FC-CE777	FC-CERB172C
	175 mm	FC-CE779	FC-CERB175C
C	Z34	FC-CE234	
D	Z50 for 34	FC-CE650	

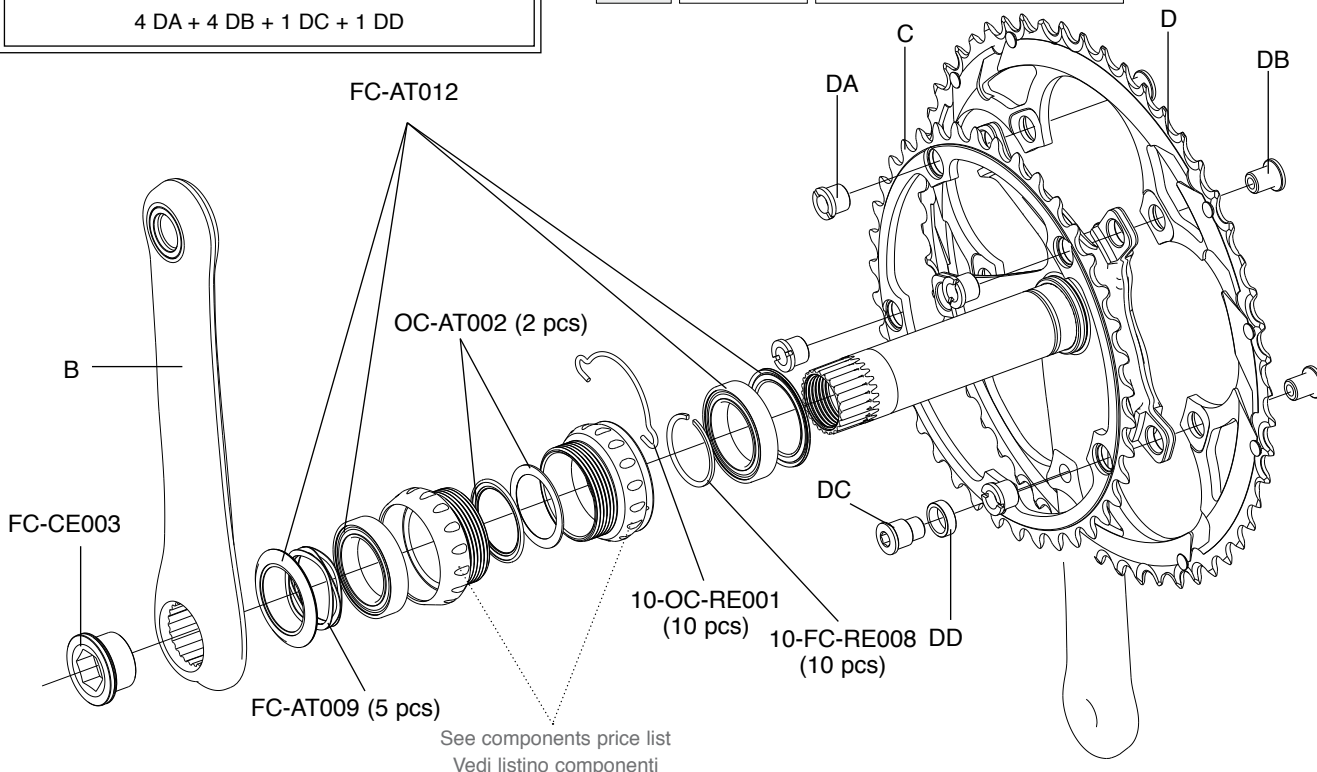

CENTAUR™ POWER-TORQUE™
10s
FC12-CE...

FC-AT300 (BLACK) / FC-CE100R (BLACK&RED)
KIT VITI / SCREWS&NUTS

4 DA + 4 DB + 1 DC + 1 DD

	BLACK	BLACK & RED
--	-------	-------------

B	170 mm	FC-CEB170	FC-CEBR170
	172,5 mm	FC-CEB172	FC-CEBR172
	175 mm	FC-CEB175	FC-CEBR175
C	Z39	FC-CE239	
D	Z52 for 39	FC-CE452	
	Z53 for 39	FC-CE453	

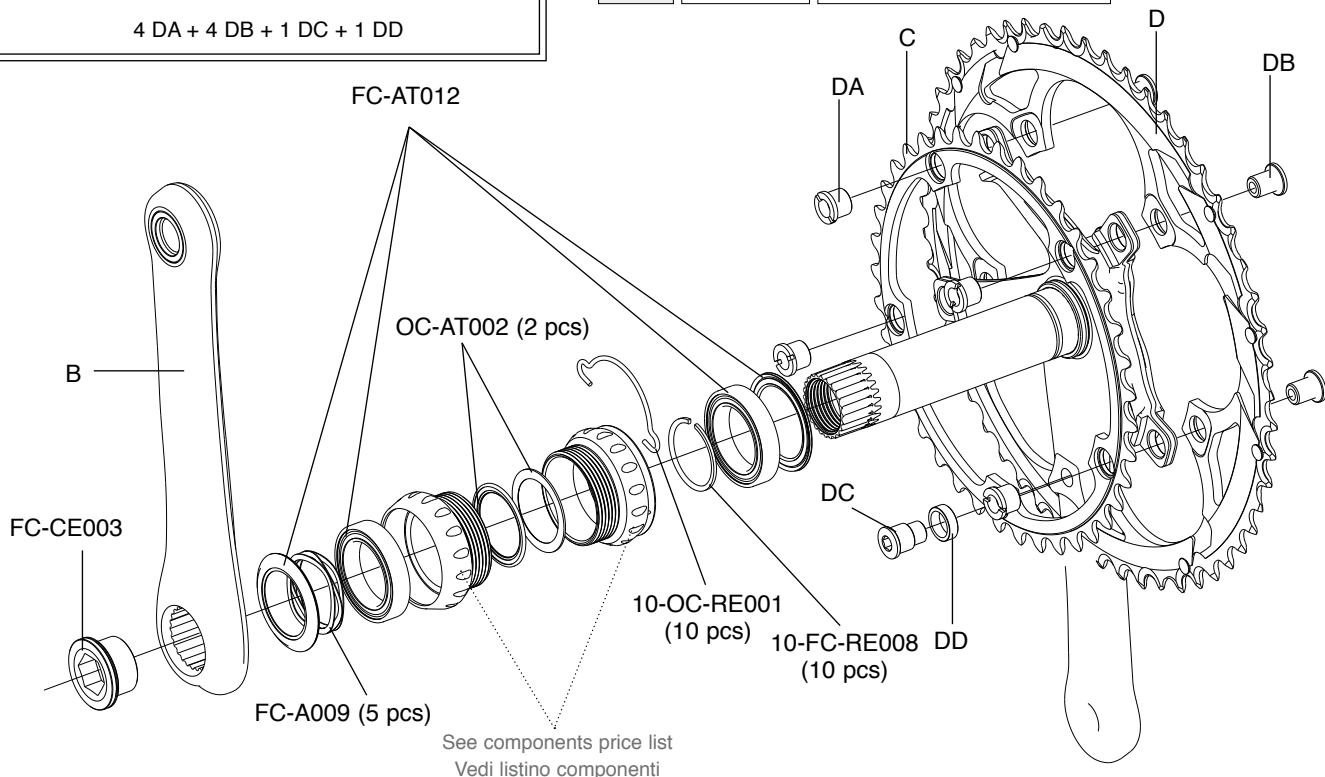

CENTAUR™ POWER-TORQUE™
CT™ 10s
FC12-CE...

FC-AT300 (BLACK) / FC-CE100R (BLACK&RED)
KIT VITI / SCREWS&NUTS

4 DA + 4 DB + 1 DC + 1 DD

	BLACK	BLACK & RED
--	-------	-------------

B	170 mm	FC-CEB170	FC-CERB170
	172,5 mm	FC-CEB172	FC-CERB172
	175 mm	FC-CEB175	FC-CERB175
C	Z34	FC-CE334	
D	Z50 for 34	FC-CE650	

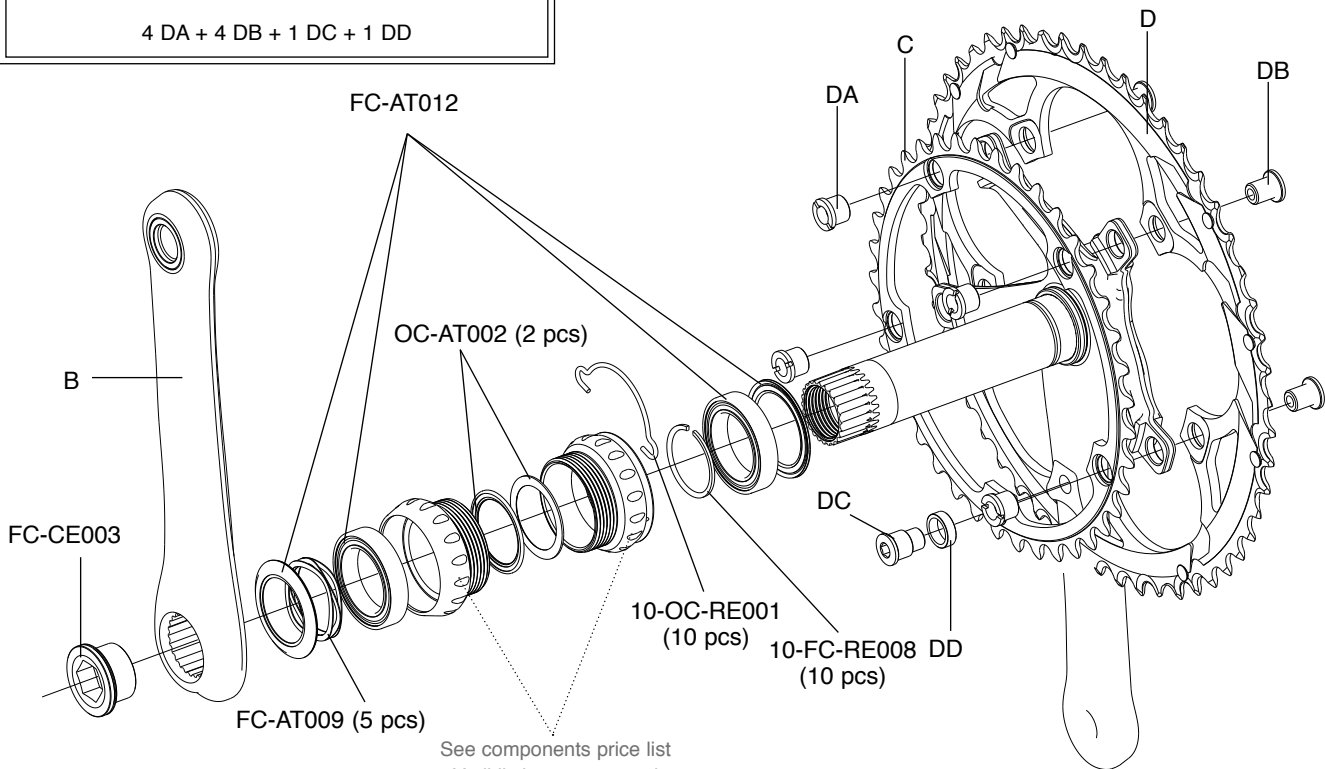

See components price list
 Vedi listino componenti

VELOCE™ POWER-TORQUE™
10s
FC11-VL...

FC-AT300
KIT VITI / SCREWS&NUTS
 4 DA + 4 DB + 1 DC + 1 DD

		BLACK	SILVER
B	170 mm	FC-VL571	FC-VL945
	172,5 mm	FC-VL573	FC-VL947
	175 mm	FC-VL575	FC-VL949
C	Z39	FC-VL339	FC-VL439
D	Z52 for 39	FC-CE252	FC-VL652
	Z53 for 39	FC-CE253	FC-VL553

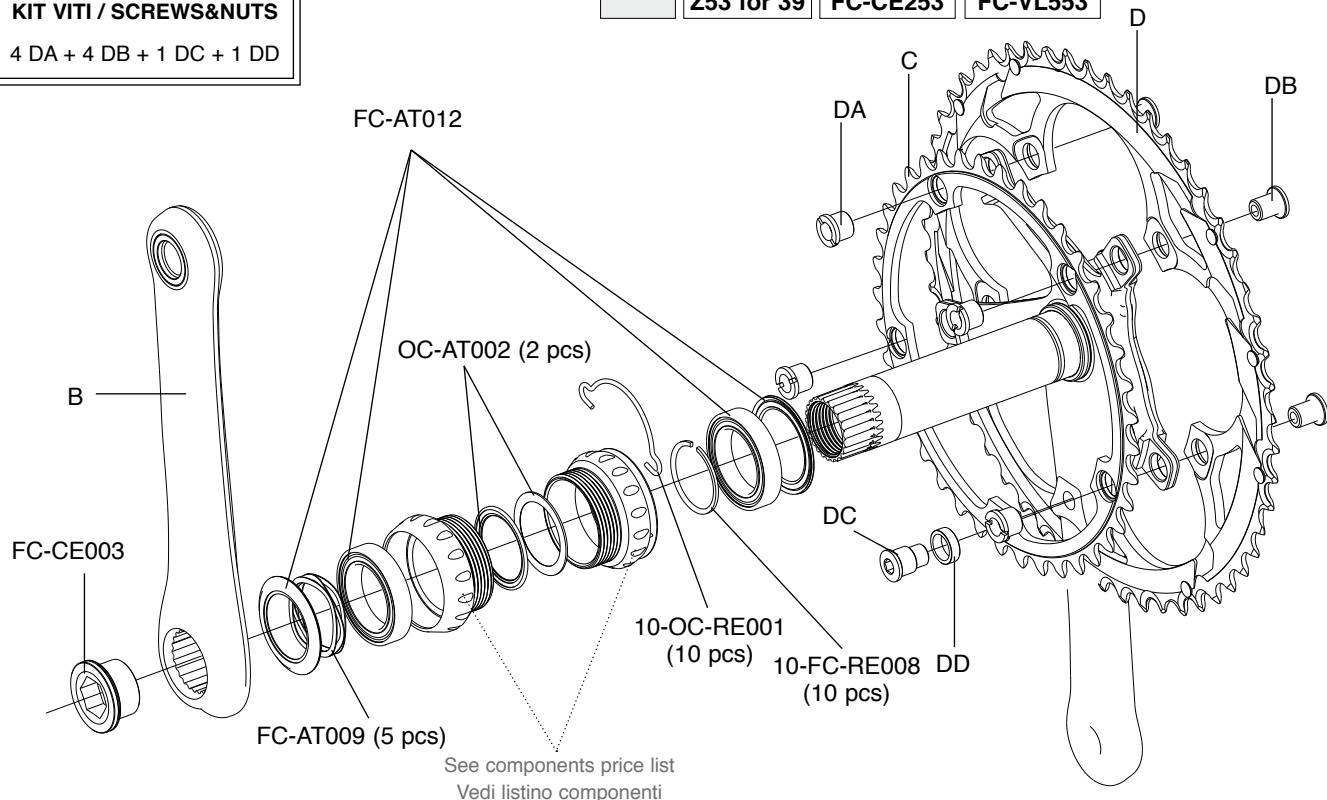

VELOCE™ POWER-TORQUE™
CT™ 10s
FC11-VL...

FC-AT300
KIT VITI / SCREWS&NUTS
 4 DA + 4 DB + 1 DC + 1 DD

		BLACK	SILVER
B	170 mm	FC-VL571	FC-VL945
	172,5 mm	FC-VL573	FC-VL947
	175 mm	FC-VL575	FC-VL949
C	Z34	FC-VL434	FC-VL534
D	Z50 for 34	FC-CE450	FC-VL450

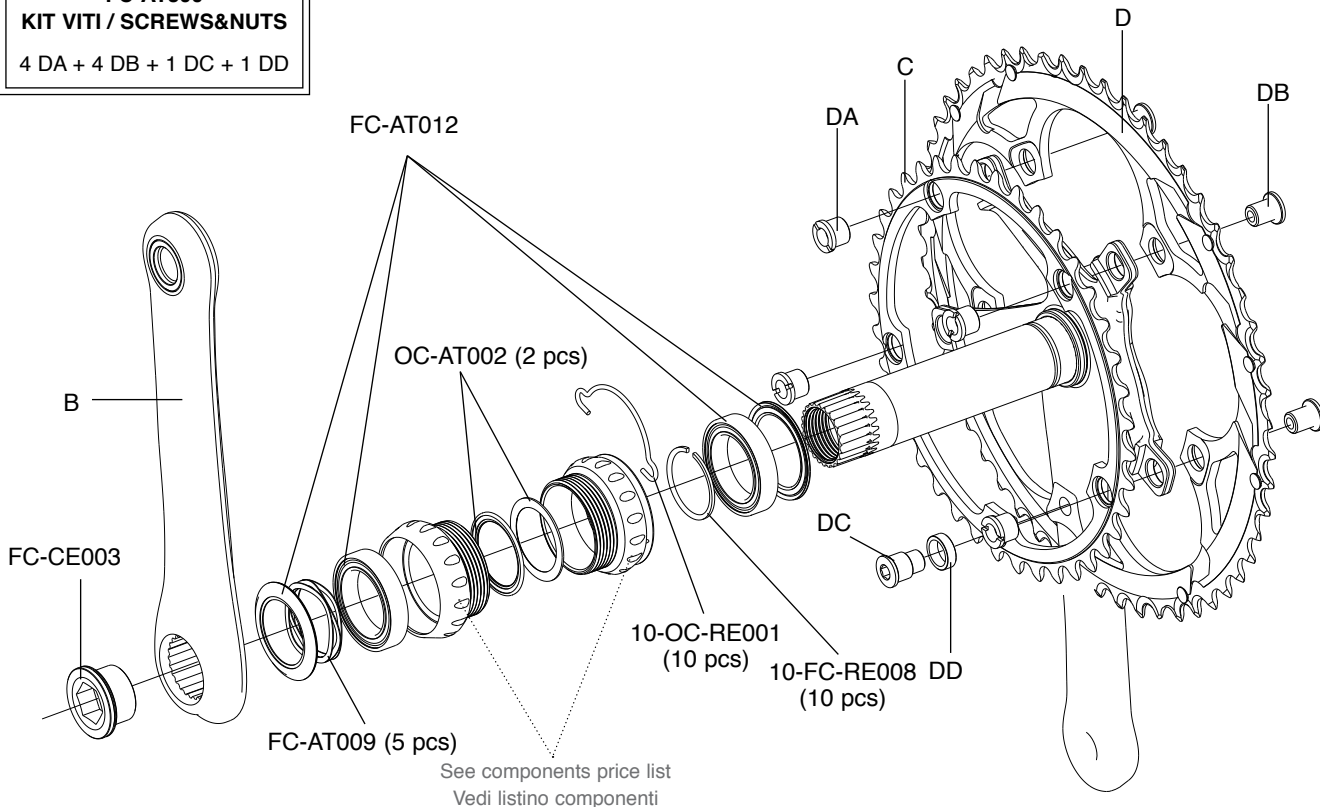

CX™ POWER-TORQUE™

11s

FC11-CX1...

FC-AT300
KIT VITI / SCREWS&NUTS

4 DA + 4 DB + 1 DC + 1 DD

		CARBON	ALUMINIUM
--	--	--------	-----------

B	170 mm	FC-CX787	FC-CX636
	172,5 mm	FC-CX789	FC-CX637
	175 mm	FC-CX791	FC-CX638
C	Z34	FC-CX134	FC-CX234
	Z36	FC-CX236	FC-CX336
D	Z46 for 36	FC-CX246	FC-CX346
	Z50 for 34	FC-CX250	FC-CX350

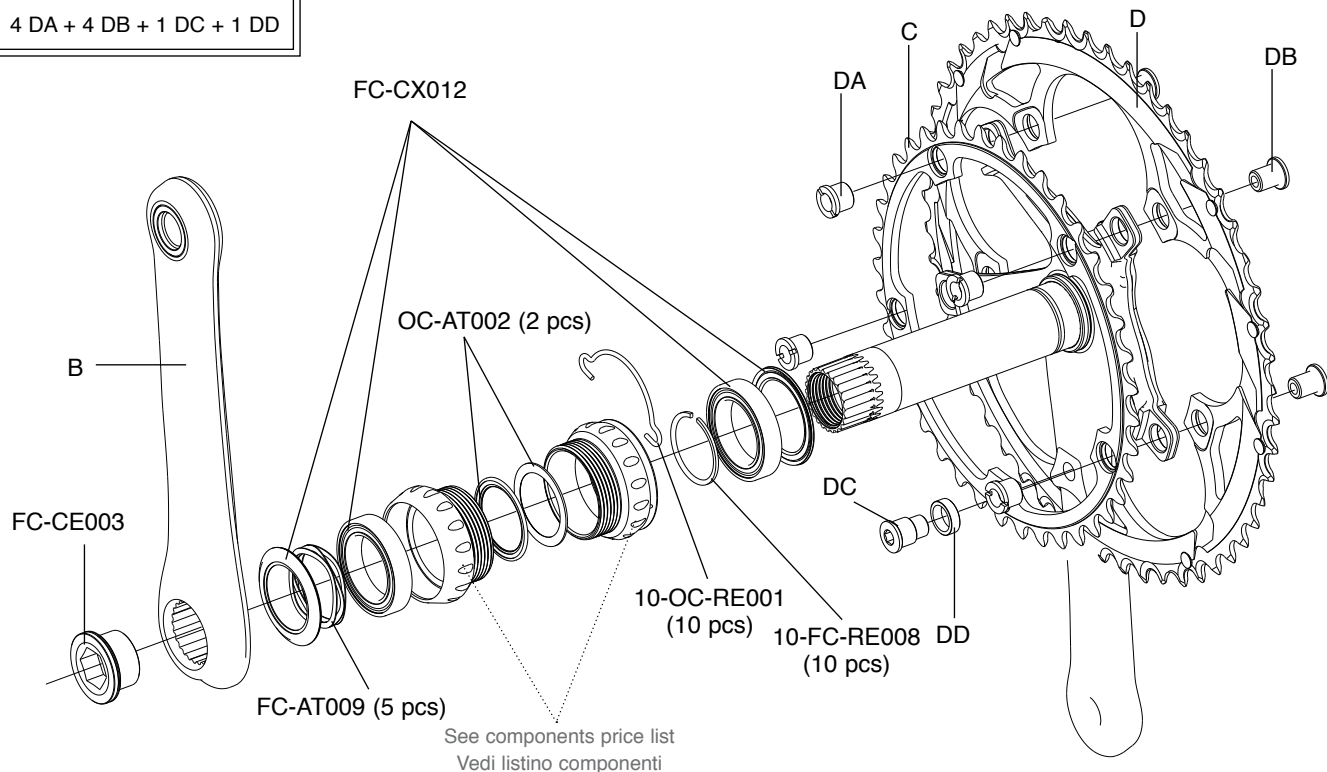

CX™ POWER-TORQUE™
10s
FC11-CXX...

FC-AT300
KIT VITI / SCREWS&NUTS

4 DA + 4 DB + 1 DC + 1 DD

	CARBON	ALUMINIUM
--	---------------	------------------

B	170 mm	FC-CX799	FC-CX656
	172,5 mm	FC-CX801	FC-CX657
	175 mm	FC-CX803	FC-CX658
C	Z34	FC-CE334	FC-CX034
	Z36	FC-CX136	FC-CX036
D	Z46 for 36	FC-CX146	FC-CX046
	Z50 for 34	FC-CX150	FC-CX050

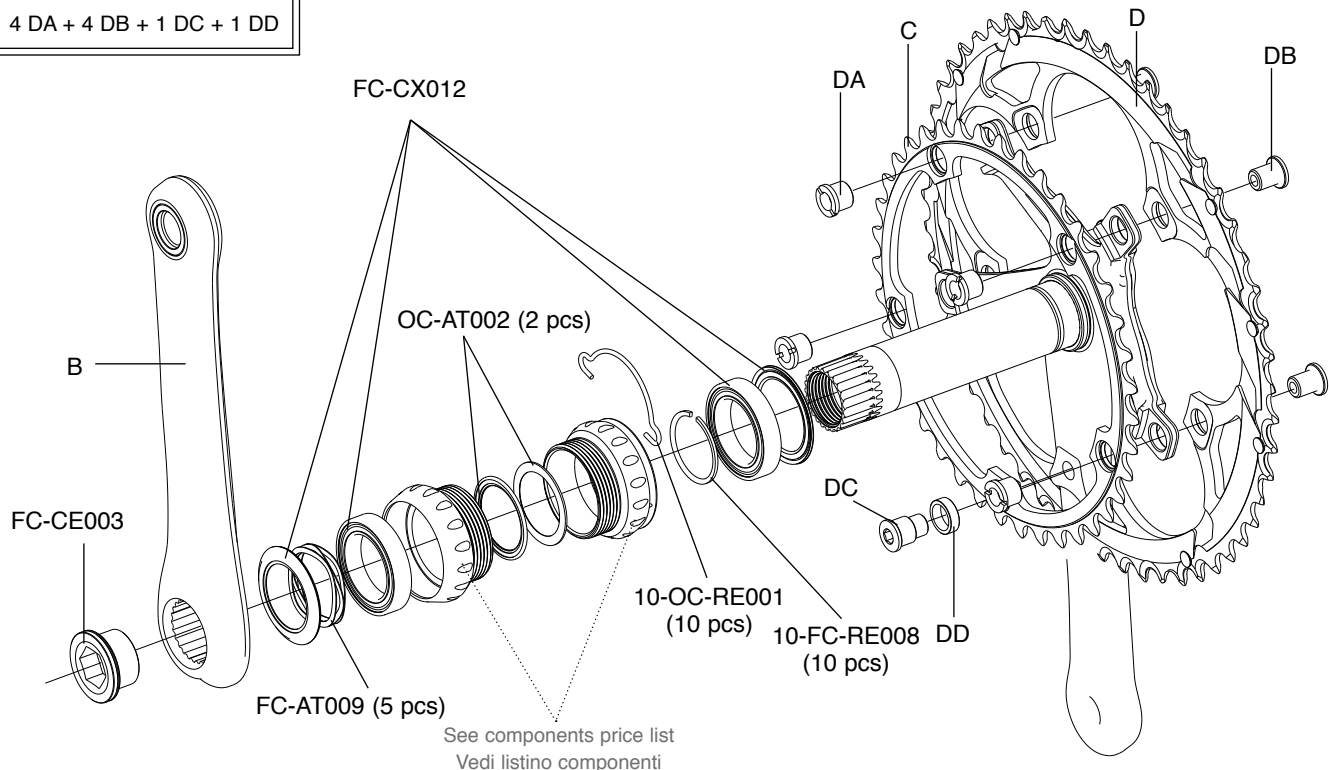

COMP TRIPLE™ 10s
FC7-CO....

FC-CO100
KIT VITI / SCREWS&NUTS

5 P + 5 R + 5 S

B	170 mm	FC-CO313
	175 mm	FC-CO315
C	Z30	FC-RE030
D	Z40 for 30	FC-CE040
	Z42 for 30	FC-CE042
E	Z50 for 40	FC-CE050
	Z53 for 42	FC-CE053

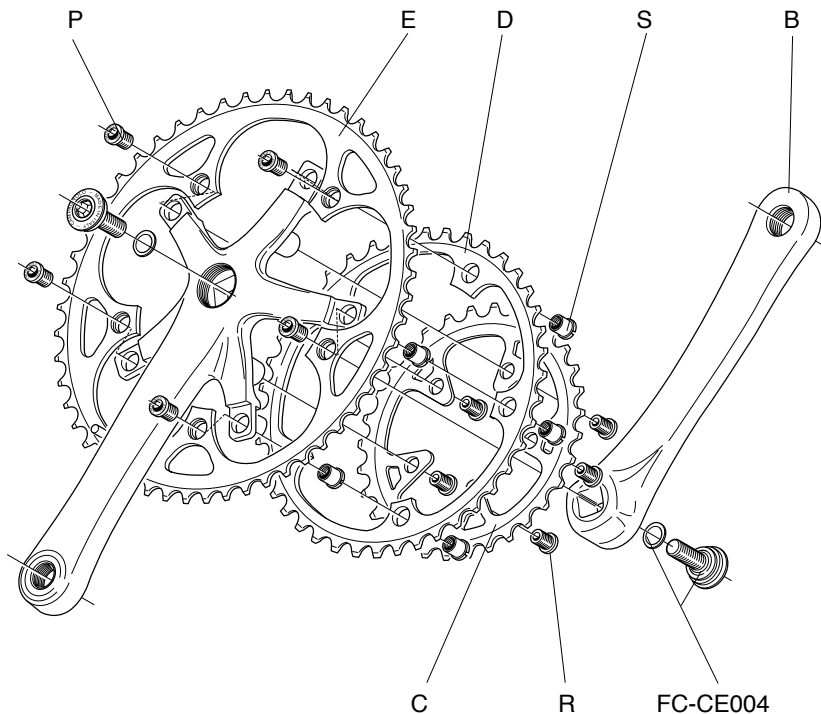

**TIME TRIAL™
CHAINRINGS**

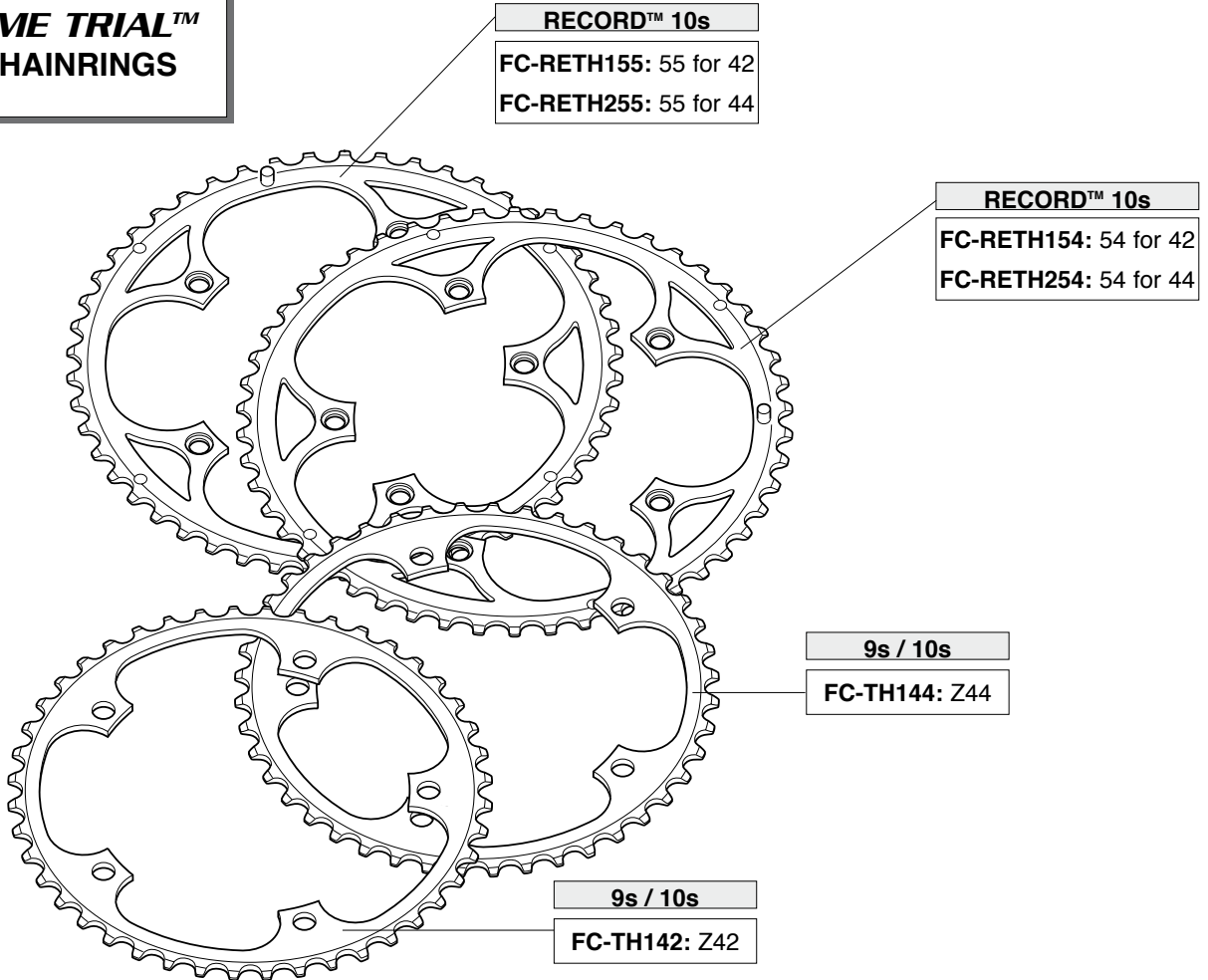

RECORD™ 10s
FC-RETH155: 55 for 42
FC-RETH255: 55 for 44

RECORD™ 10s
FC-RETH154: 54 for 42
FC-RETH254: 54 for 44

9s / 10s
FC-TH144: Z44

9s / 10s
FC-TH142: Z42

**SUPER
RECORD™ 11s
RD11-SR1**

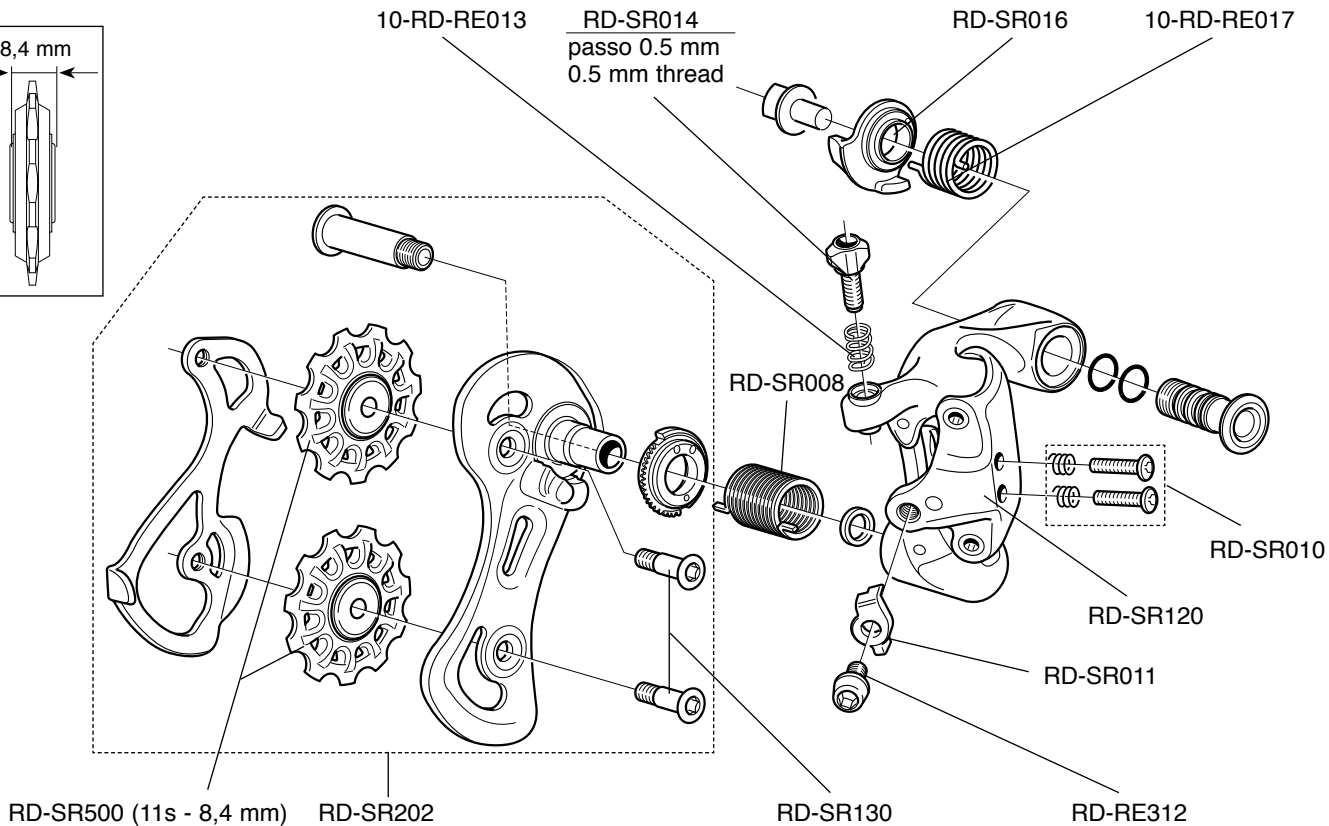
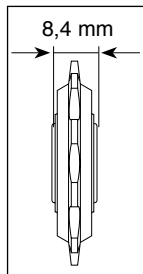

RECORD™ 11s
RD11-RE1

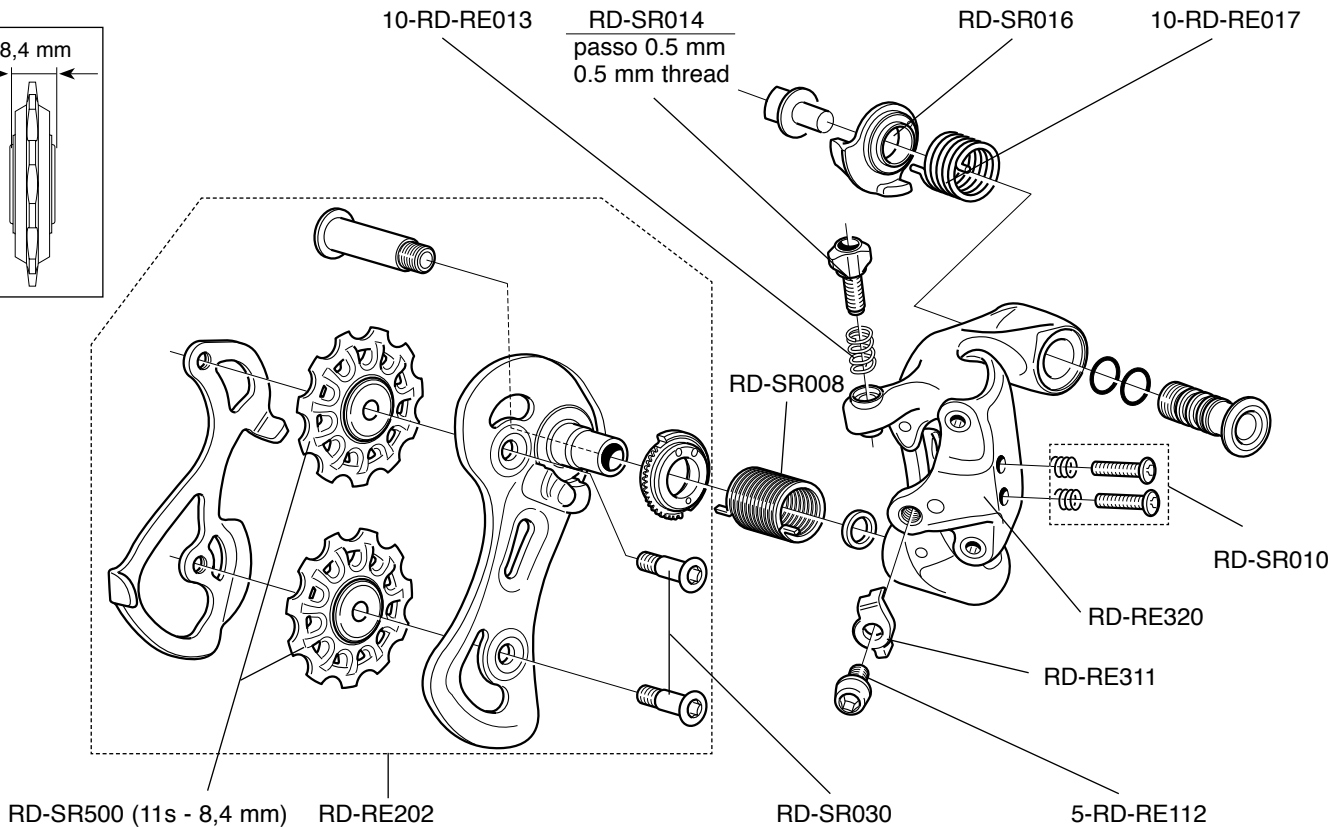
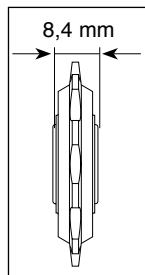

CHORUS™ 11s
RD11-CH1

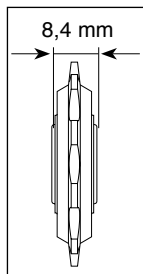

10-RD-RE013

RD-SR014
passo 0.5 mm
0.5 mm thread

RD-SR016

10-RD-RE017

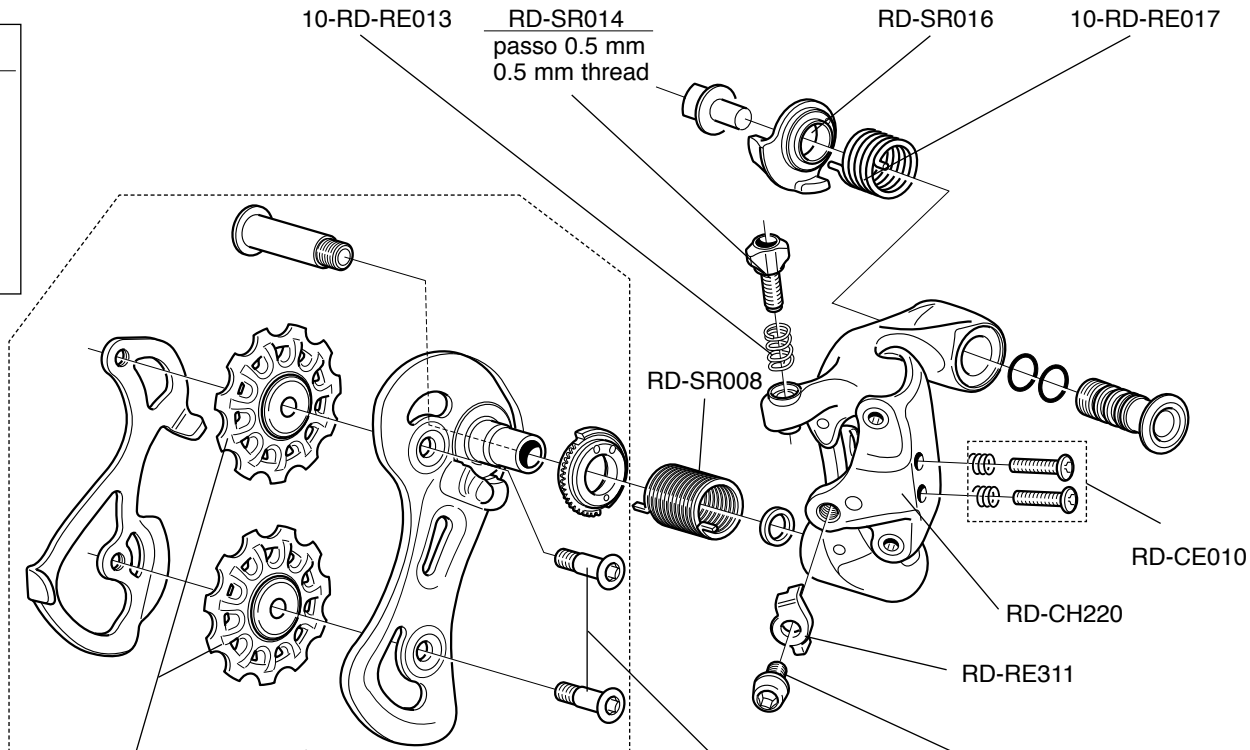

RD-CH500 (11s - 8,4 mm)

RD-CH602

RD-CH130

5-RD-RE112

ATHENA^M 11s
RD11-AT1

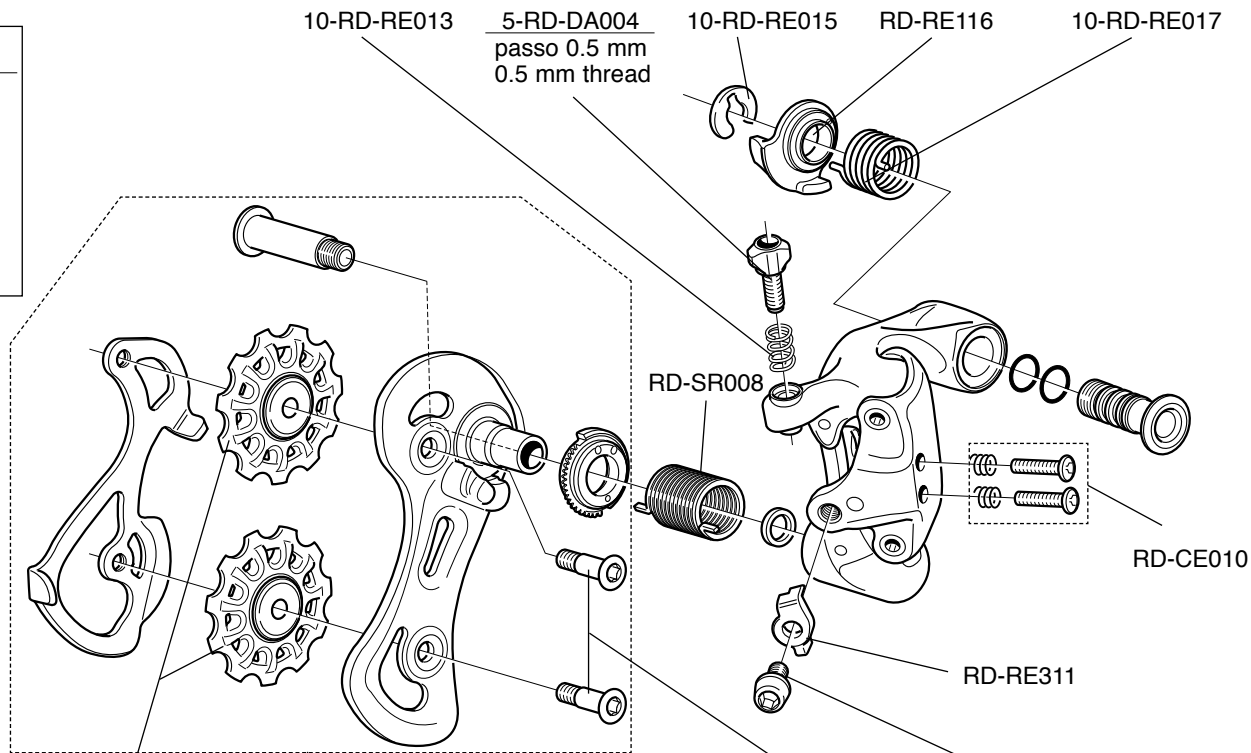
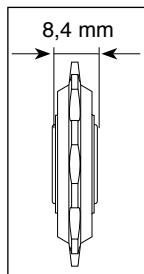

RD-CH500 (11s - 8,4 mm)

RD-AT202 (SILVER) - RD-AT002B (BLACK)

RD-CH130

5-RD-RE112

CENTAUR™ 10s
RD11-CEX
RD12-CERBX

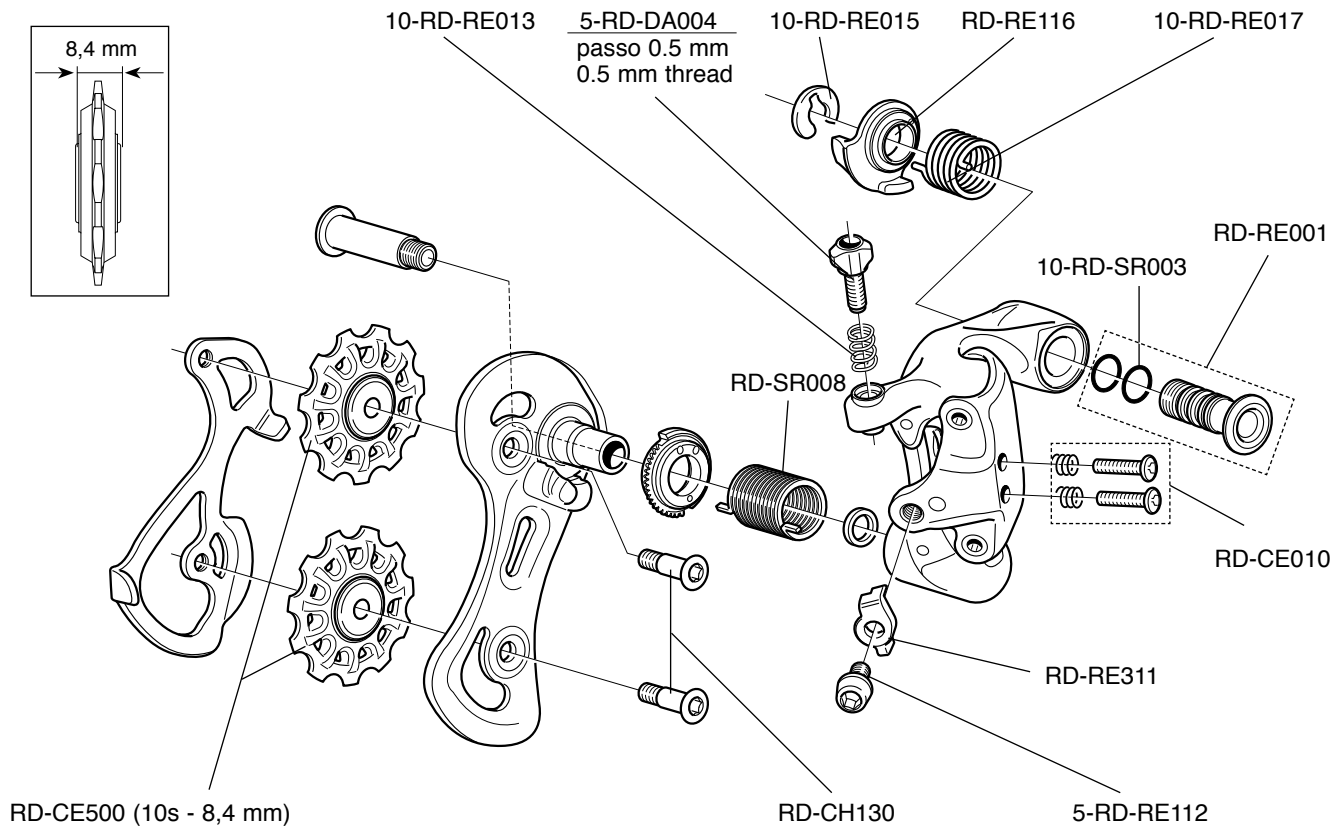
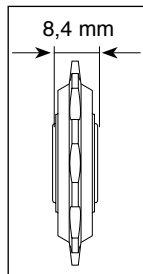

VELOCE™ 10s
RD11-VLXS
RD11-VLXM

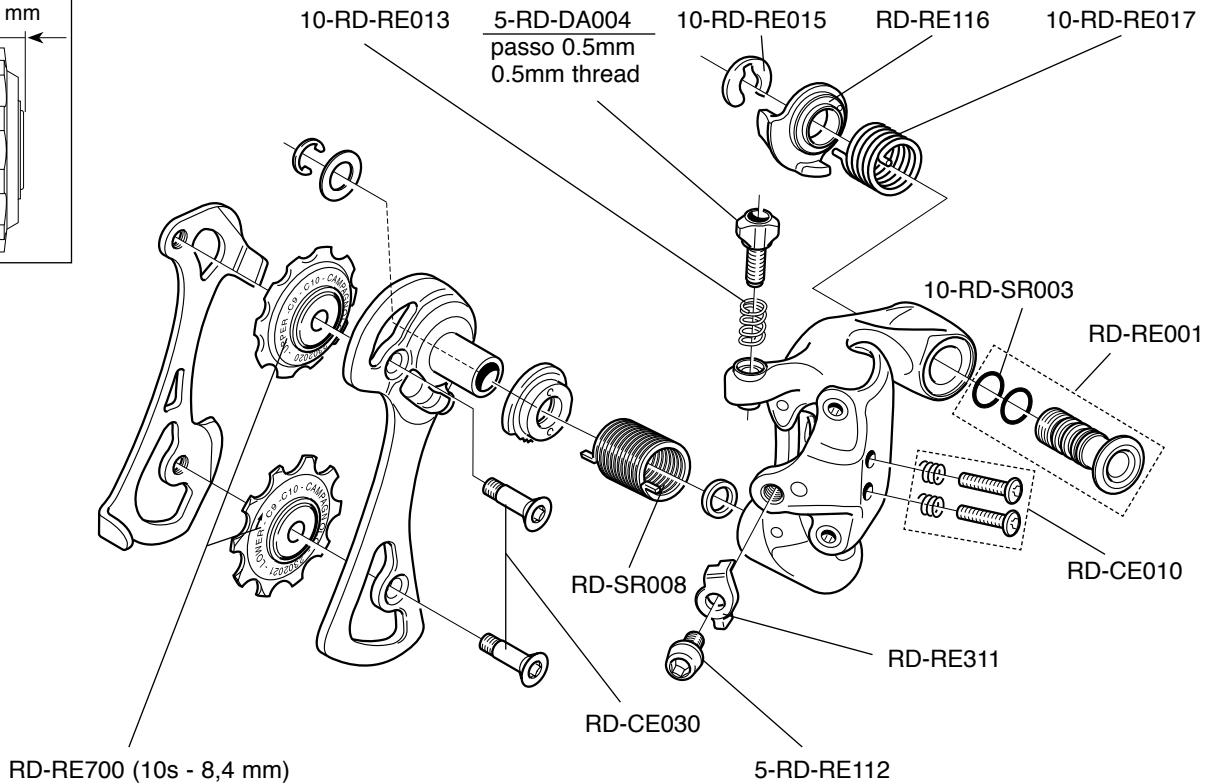
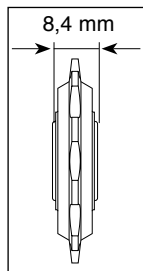

COMP TRIPLE™
10s
RD7-COXL

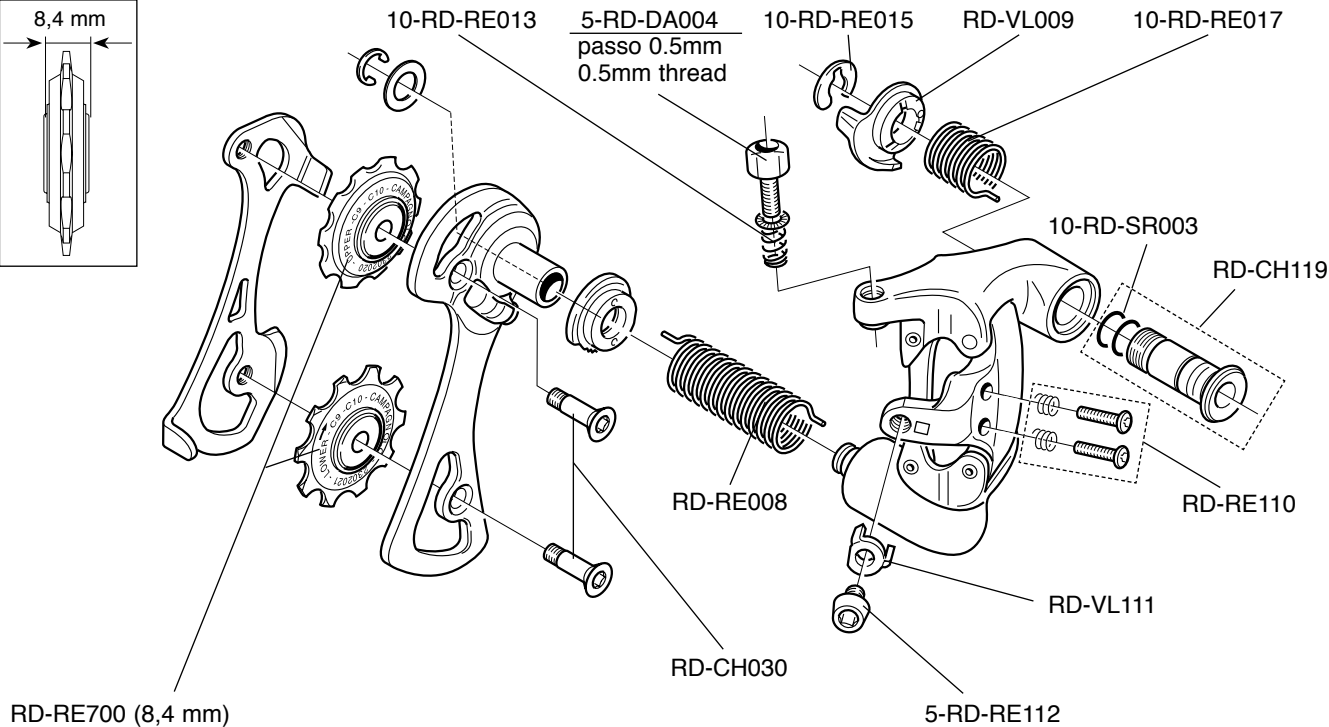
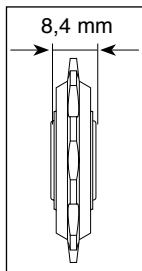

SUPER RECORD™

11s

FD11-SR2..

ø 32 mm	FD-SR021
ø 35 mm	FD-SR022

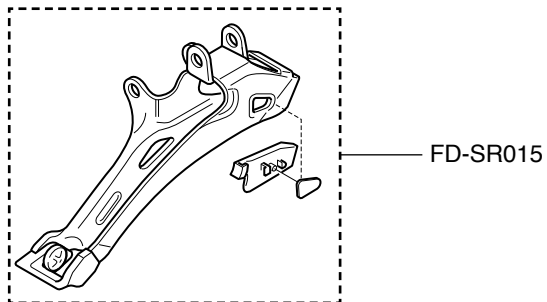
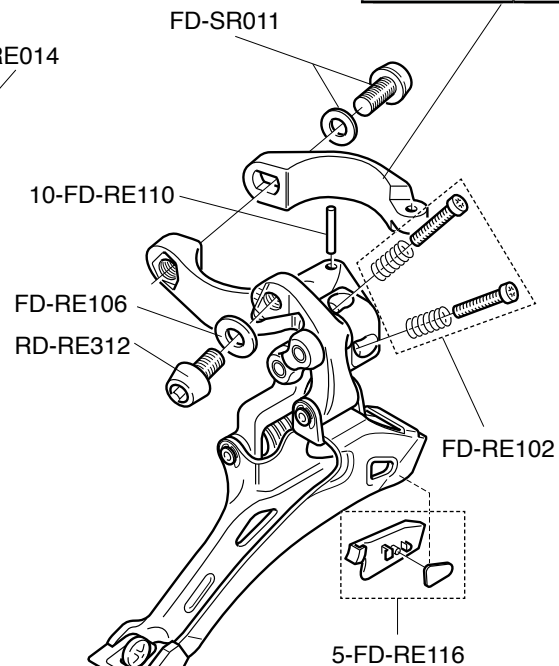
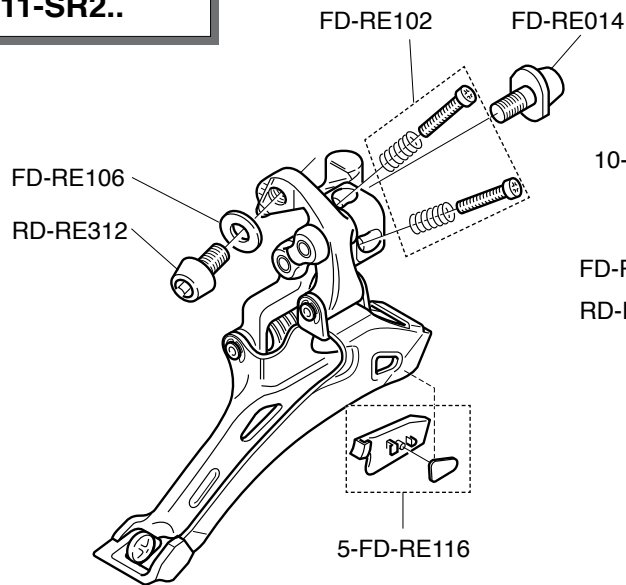

RECORD™ 11s
FD11-RE2..

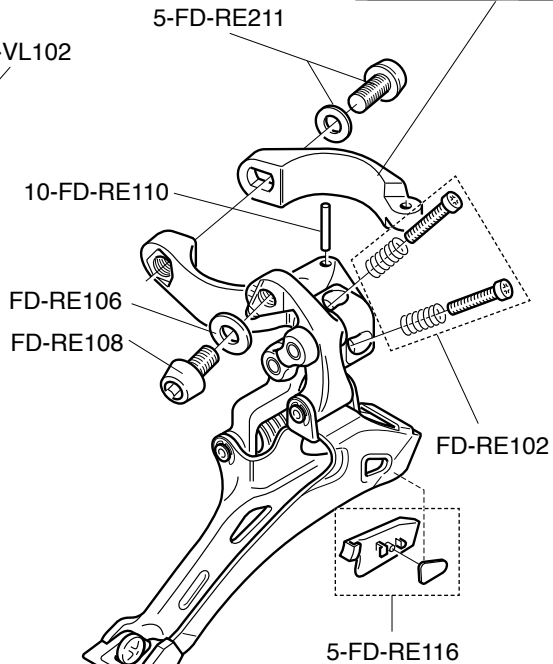
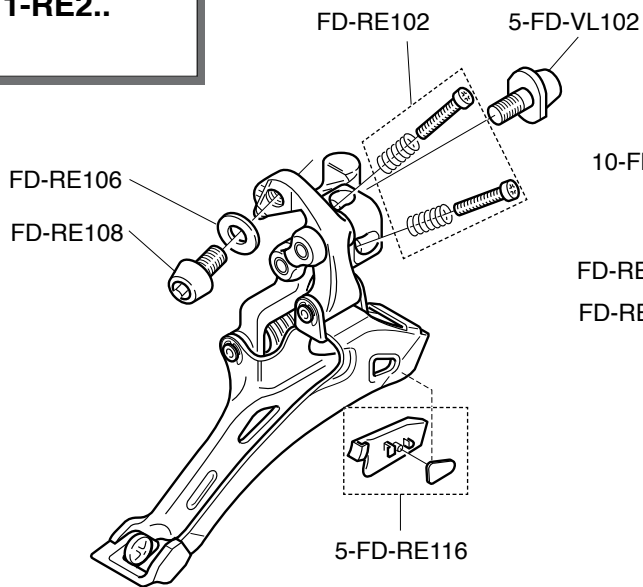

ø 32 mm	FD-RE321
ø 35 mm	FD-RE322

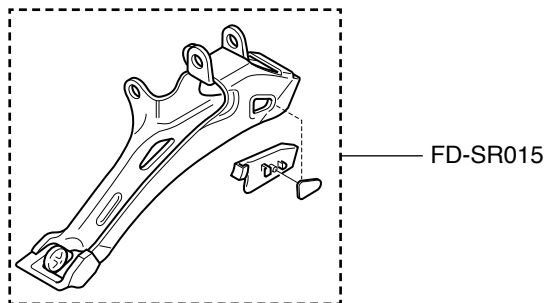

CHORUS™ 11s
FD11-CH2..

∅ 32 mm	FD-RE321
∅ 35 mm	FD-RE322

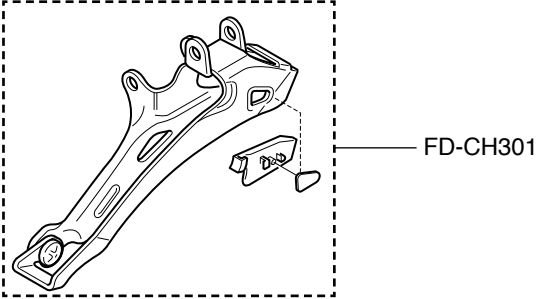
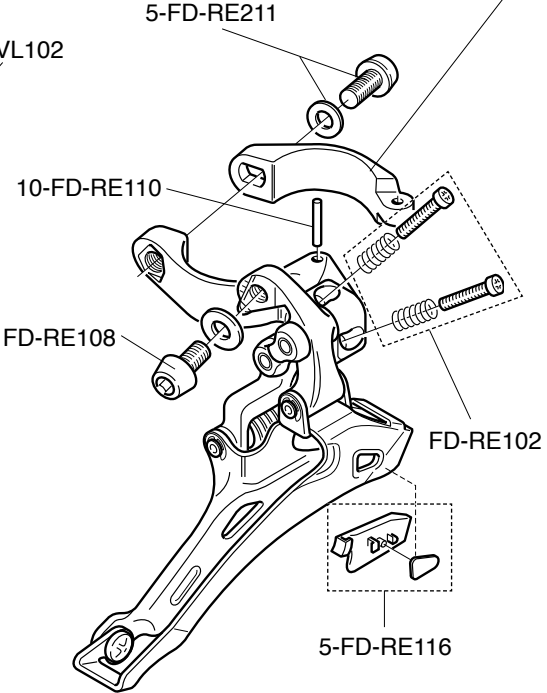
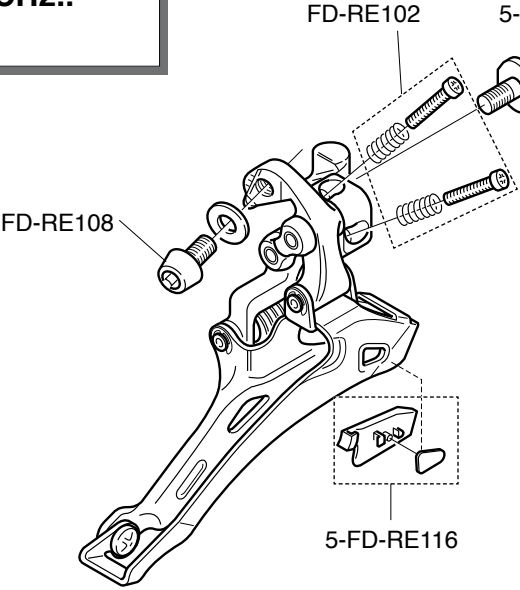

ATHENA™ 11s
FD11-AT2..

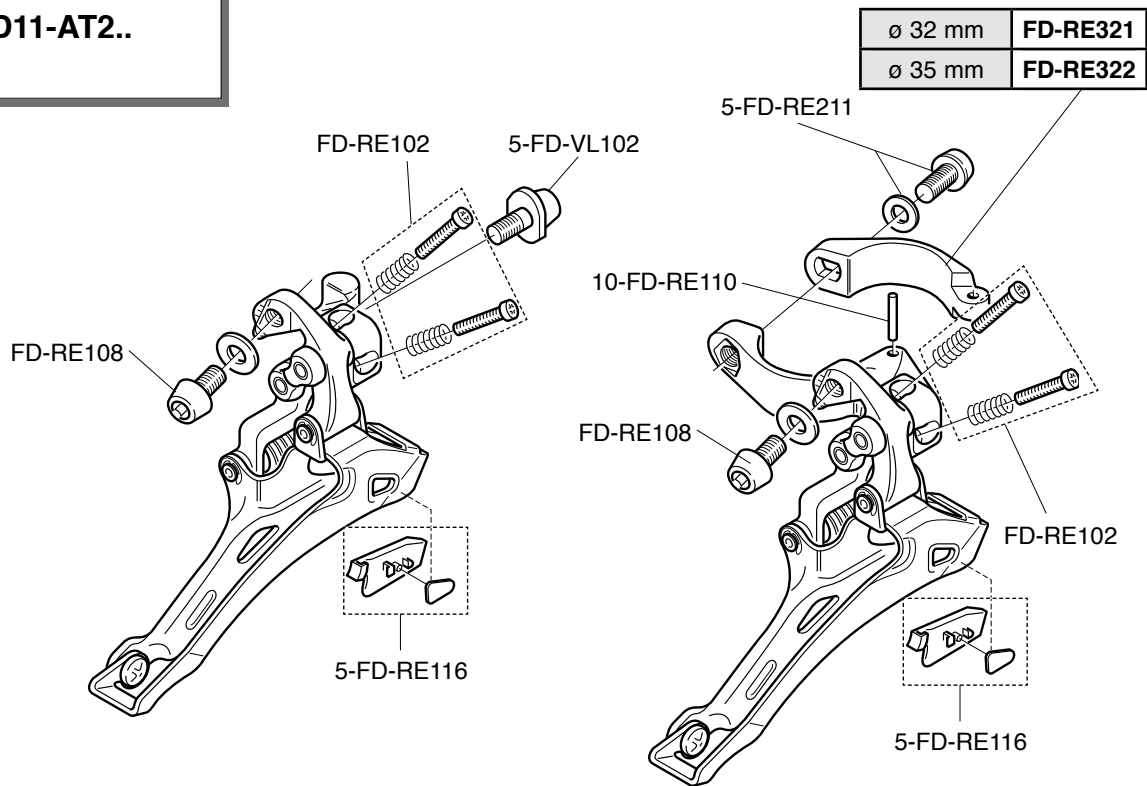

CENTAUR™ 10s
FD11-CE2..
FD12-CERB2..

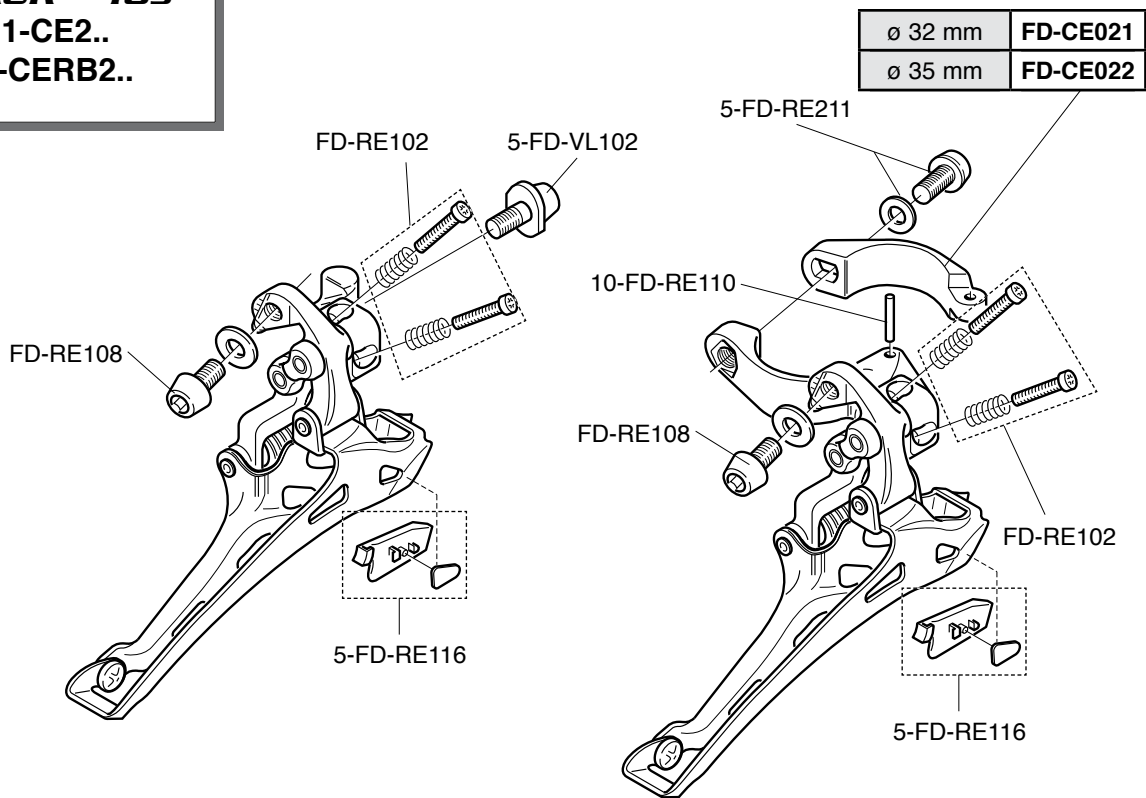

VELOCE™ 10s
FD11-VL2..

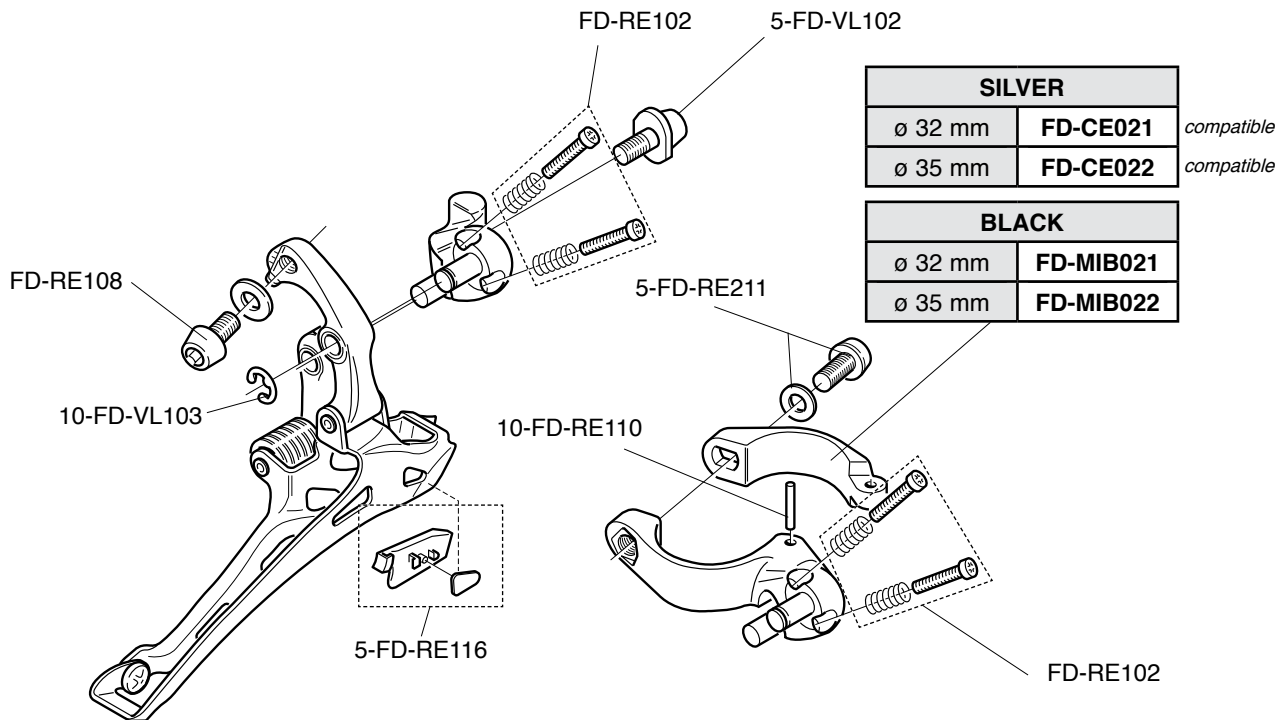

COMP TRIPLE™
10s
FD7-CO3..

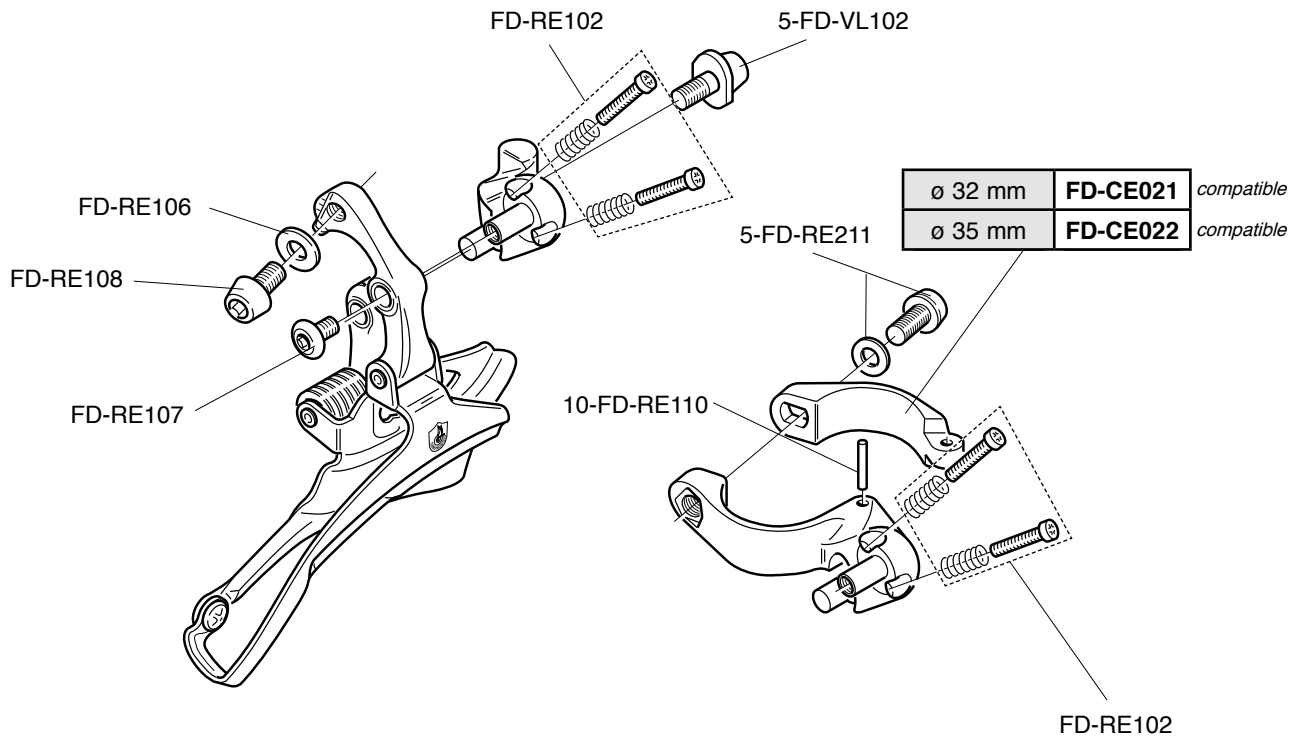

**SUPER RECORD™
ULTRA-SHIFT™ 115
EP11-SR1C**

BLACK	WHITE	RED
EC-SR500 (R+L)	EC-SR500W (R+L)	EC-SR500R (R+L)

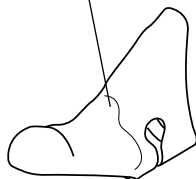

EC-SR103 (2 pcs)

(only left)
R: EC-SR060
L: EC-SR061

R: EC-SR004
L: EC-SR005

R: EC-SR100
L: EC-SR101

(insert for big hands)
EC-SR040 (R+L)

EC-SR050
(R+L - 5 pairs)

R: EC-SR147
L: EC-SR148

R.H. COMPLETE CONTROL LEVER / COMANDO DX COMPLETO
EP11-SR1R
L.H. COMPLETE CONTROL LEVER / COMANDO SX COMPLETO
EP11-SR1L

RECORD™
ULTRA-SHIFT™ 115
EP11-RE1C

BLACK	WHITE	RED
EC-SR500 (R+L)	EC-SR500W (R+L)	EC-SR500R (R+L)

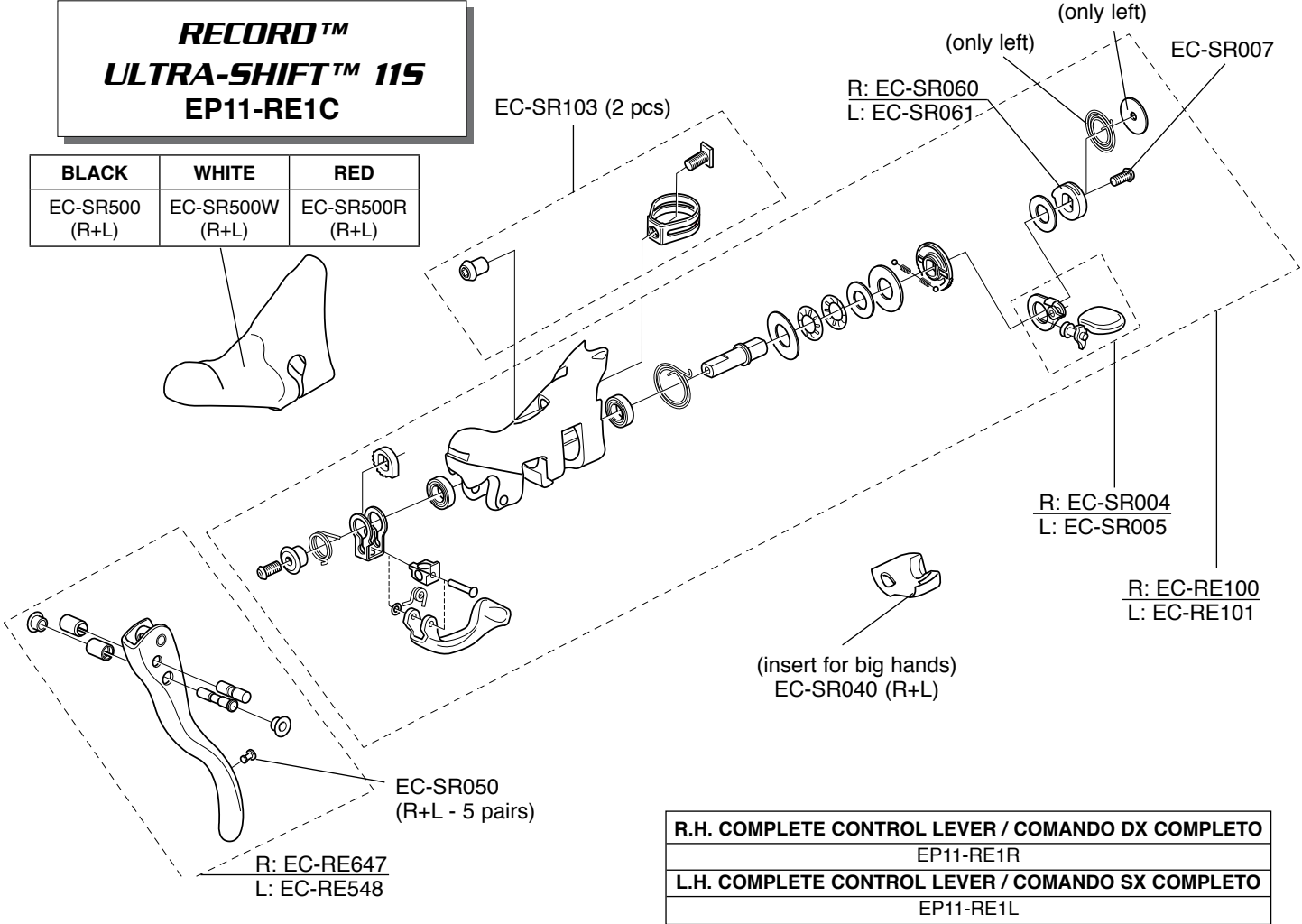

R.H. COMPLETE CONTROL LEVER / COMANDO DX COMPLETO
EP11-RE1R
L.H. COMPLETE CONTROL LEVER / COMANDO SX COMPLETO
EP11-RE1L

CHORUS™
ULTRA-SHIFT™ 115
EP11-CH1C

BLACK	WHITE	RED
EC-SR500 (R+L)	EC-SR500W (R+L)	EC-SR500R (R+L)

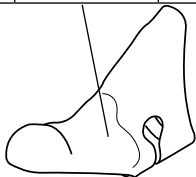

EC-SR103 (2 pcs)

R: EC-SR060
 L: EC-SR061

(only left)

(only left)

EC-SR007

R: EC-SR004
 L: EC-SR005

R: EC-RE100
 L: EC-RE101

(insert for big hands)
 EC-SR040 (R+L)

EC-SR050
 (R+L - 5 pairs)

R: EC-CH747
 L: EC-CH648

R.H. COMPLETE CONTROL LEVER / COMANDO DX COMPLETO
EP11-CH1R
L.H. COMPLETE CONTROL LEVER / COMANDO SX COMPLETO
EP11-CH1L

ATHENA™
POWER-SHIFT™ 115
EP11-AT1C - EP11-AT1CC

BLACK	WHITE	RED
EC-AT500B (R+L)	EC-AT500W (R+L)	EC-AT500R (R+L)

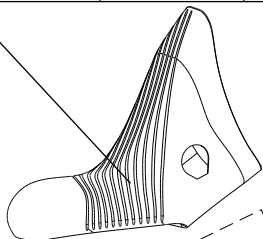

EC-SR050
(R+L - 5 pairs)

- R: EC-AT547 (carbon)
 EC-AT647 (silver)
 EC-AT647B (black)
-
- L: EC-AT548 (carbon)
 EC-AT648 (silver)
 EC-AT648B (black)

EC-SR103 (2 pcs)

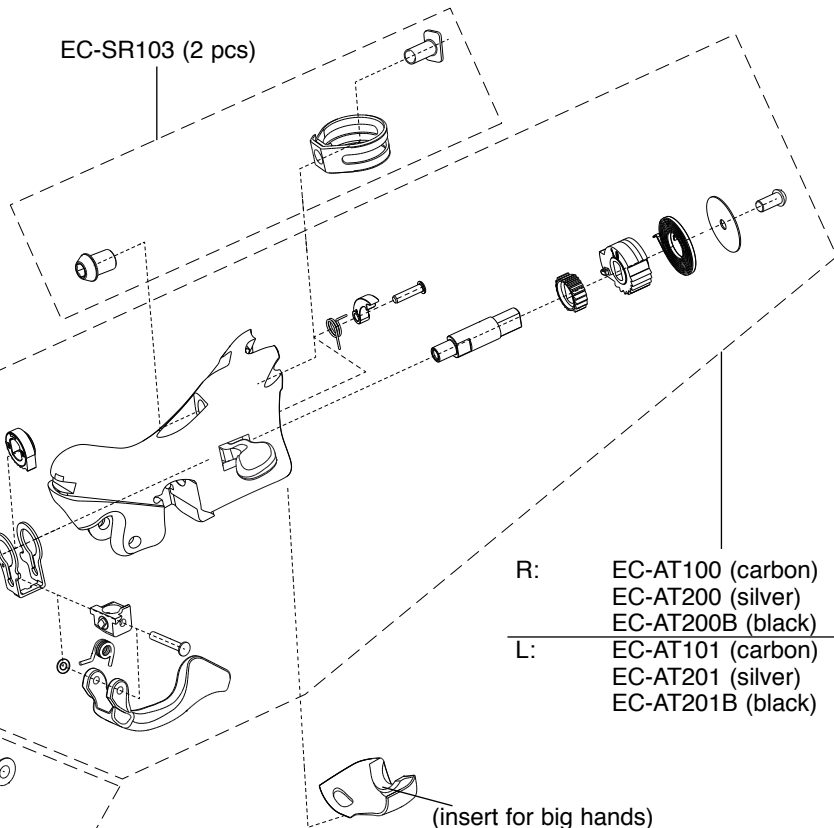

- R: EC-AT100 (carbon)
 EC-AT200 (silver)
 EC-AT200B (black)
-
- L: EC-AT101 (carbon)
 EC-AT201 (silver)
 EC-AT201B (black)

(insert for big hands)
 EC-SR040 (R+L)

R.H. COMPLETE CONTROL LEVER / COMANDO DX COMPLETO

EP11-AT1R (silver) - EP12-ATB1R (black) - EP11-AT1CR (Carbon)

L.H. COMPLETE CONTROL LEVER / COMANDO SX COMPLETO

EP11-AT1L (silver) - EP12-ATB1L (black) - EP11-AT1CL (Carbon)

CENTAUR™
POWER-SHIFT™ 10s
EP11-CEXC - EP11-CEXCC
EP12-CERBXC - EP12-CERBXCC

BLACK	WHITE	RED
EC-AT500B (R+L)	EC-AT500W (R+L)	EC-AT500R (R+L)

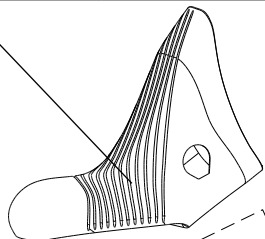

EC-SR103 (2 pcs)

R: EC-CE300
 L: EC-AT101

EC-SR050
 (R+L - 5 pairs)

R: EC-CE647 (C)
 EC-CE647RB (C B&R)
 EC-CE747 (A)
 EC-CE747RB (A B&R)

L: EC-CE648 (C)
 EC-CE648RB (C B&R)
 EC-CE748 (A)
 EC-CE748RB (A B&R)

(insert for big hands)
 EC-SR040 (R+L)

R.H. COMPLETE CONTROL LEVER / COMANDO DX COMPLETO

EP11-CEXR (A)/EP12-CERBXR (A B&R)/EP11-CEXCR (C)/EP12-CERBXCR (C B&R)

L.H. COMPLETE CONTROL LEVER / COMANDO SX COMPLETO

EP11-CEXL (A)/EP12-CERBXL (A B&R)/EP11-CEXCL (C)/EP12-CERBXCL (C B&R)

VELOCE™
POWER-SHIFT™ 10s
EP11-VLBXC - EP11-VLSXC

BLACK	WHITE	RED
EC-AT500B (R+L)	EC-AT500W (R+L)	EC-AT500R (R+L)

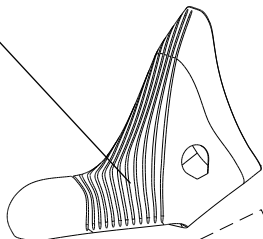

EC-SR050
(R+L - 5 pairs)

R: EC-VL047B (B) - EC-VL047S (S)
 L: EC-VL048B (B) - EC-VL048S (S)

EC-SR103 (2 pcs)

R: EC-CE300
 L: EC-AT101

(insert for big hands)
 EC-SR040 (R+L)

R.H. COMPLETE CONTROL LEVER / COMANDO DX COMPLETO
EP11-VLBXR (BLACK) - EP11-VLSXR (SILVER)
L.H. COMPLETE CONTROL LEVER / COMANDO SX COMPLETO
EP11-VLBXL (BLACK) - EP11-VLSXL (SILVER)

ESCAPE™ ALL VERSIONS

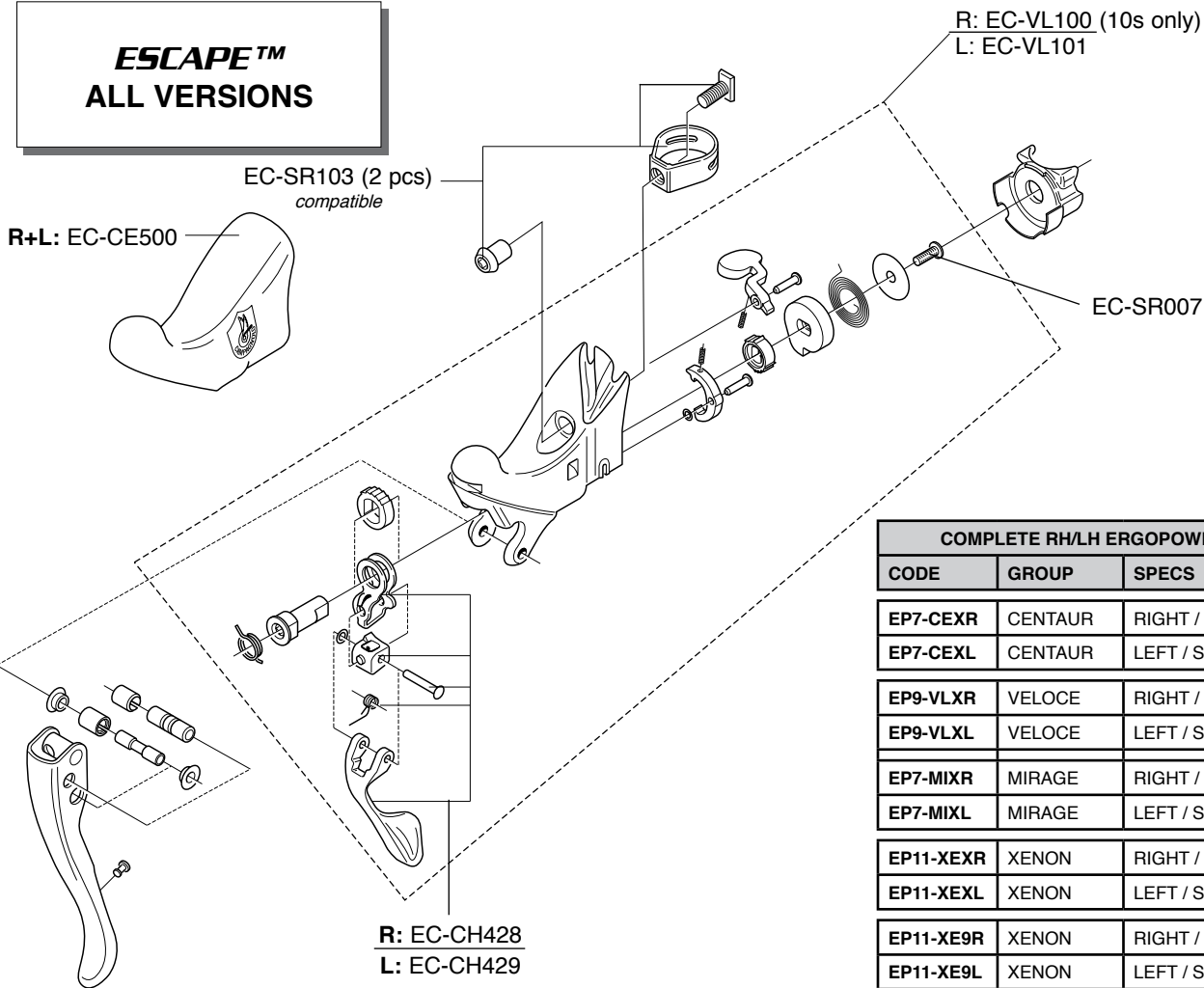

COMPLETE RH/LH ERGOPOWER		
CODE	GROUP	SPECS
EP7-CEXR	CENTAUR	RIGHT / DX 10S
EP7-CEXL	CENTAUR	LEFT / SX
EP9-VLXR	VELOCE	RIGHT / DX 10S
EP9-VLXL	VELOCE	LEFT / SX
EP7-MIXR	MIRAGE	RIGHT / DX 10S
EP7-MIXL	MIRAGE	LEFT / SX
EP11-XEXR	XENON	RIGHT / DX 10S
EP11-XEYL	XENON	LEFT / SX
EP11-XE9R	XENON	RIGHT / DX 9S
EP11-XE9L	XENON	LEFT / SX

RECORD™ QS™

**10s
EP7-REXC**

EC-SR103 (2 pcs)
compatible

R: EC-RE200
L: EC-RE101

R: EC-RE224

L: EC-RE159

R + L: EC-RE600

10-EC-RE030

R: EC-RE447

L: EC-RE348

R.H. COMPLETE CONTROL LEVER / COMANDO DX COMPLETO

EP7-REXR

L.H. COMPLETE CONTROL LEVER / COMANDO SX COMPLETO

EP7-REXL

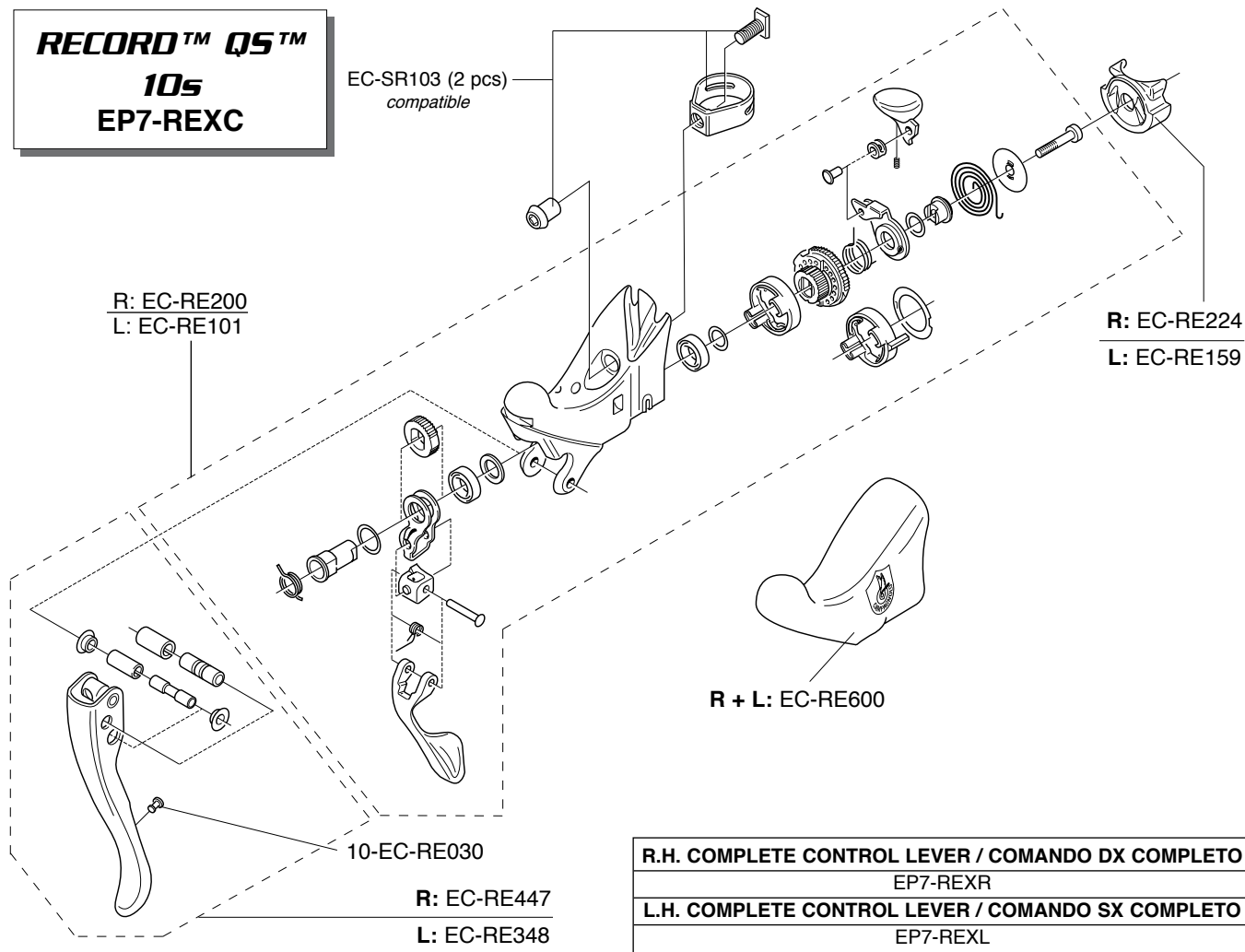

VELOCE™ FB
10s
EP6-VLXCFB

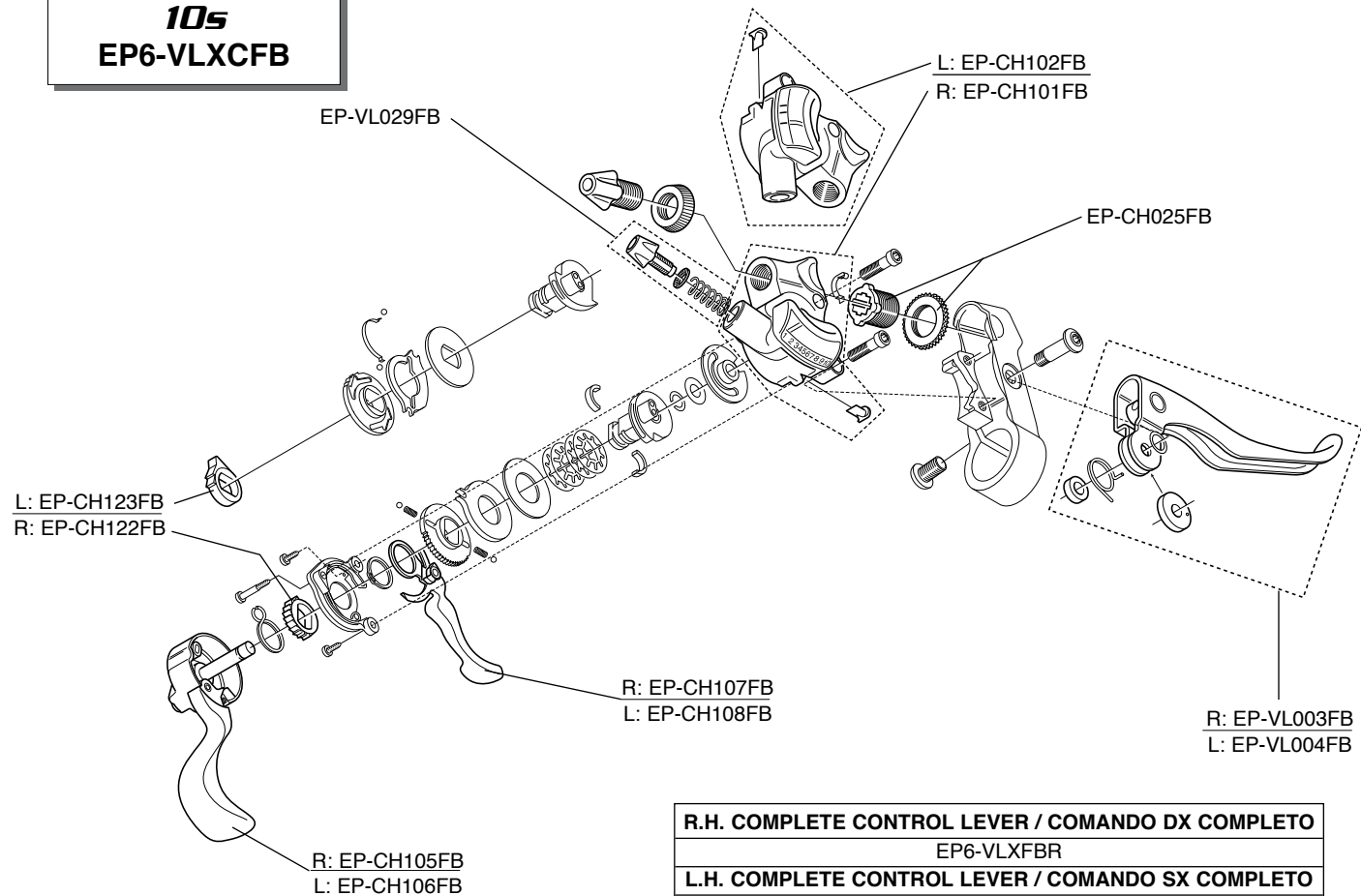

R.H. COMPLETE CONTROL LEVER / COMANDO DX COMPLETO

EP6-VLXFBR

L.H. COMPLETE CONTROL LEVER / COMANDO SX COMPLETO

EP6-VLXFBL

SUPER RECORD™-D
SKELETON™
BR11-SR - BR11-SRDP

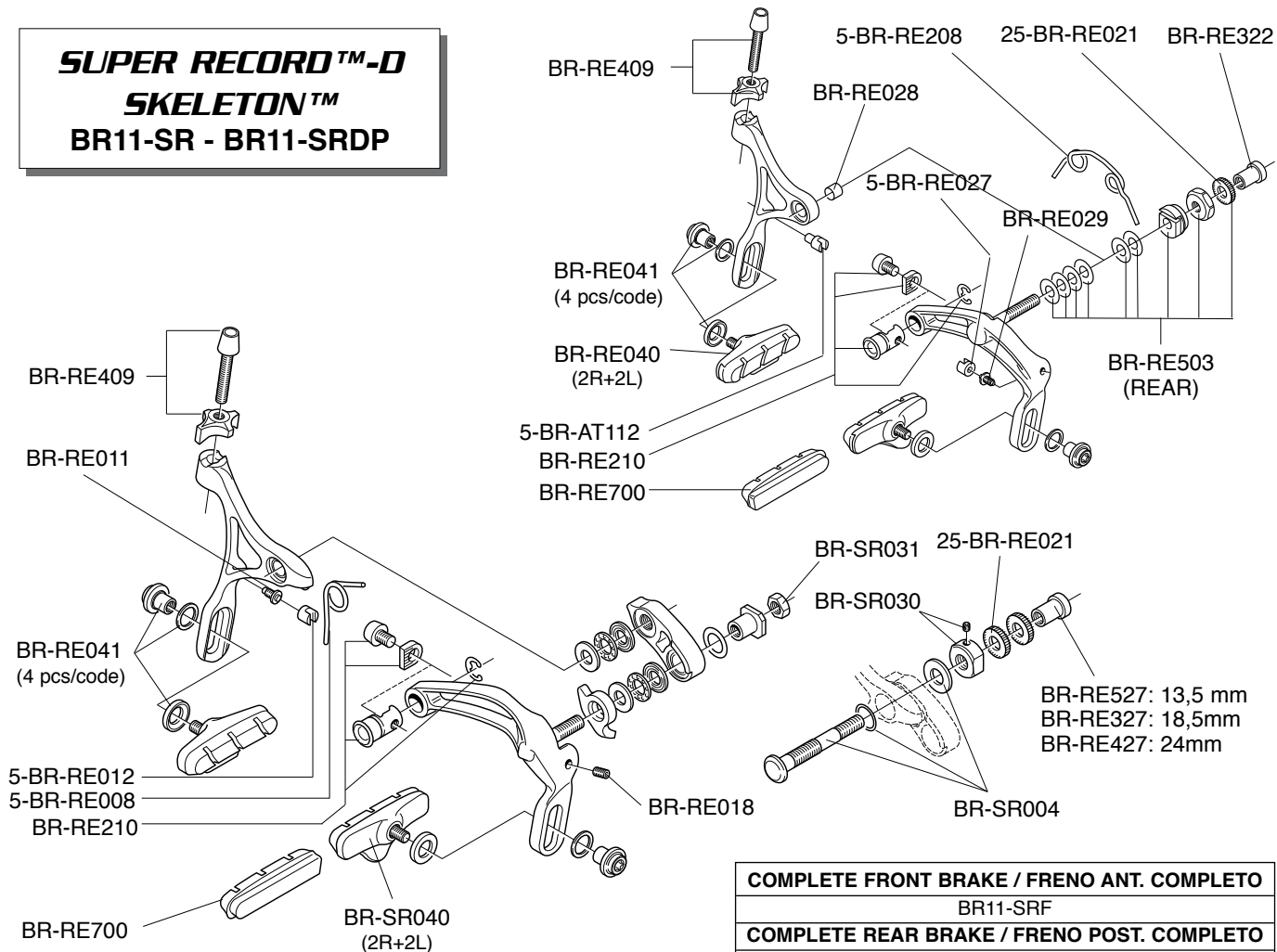

COMPLETE FRONT BRAKE / FRENO ANT. COMPLETO
BR11-SRF
COMPLETE REAR BRAKE / FRENO POST. COMPLETO
BR11-SRR (mono pivot) - BR11-SRDPR (dual pivot)

RECORD™-D
SKELETON™
BR11-RE - BR11-REDP

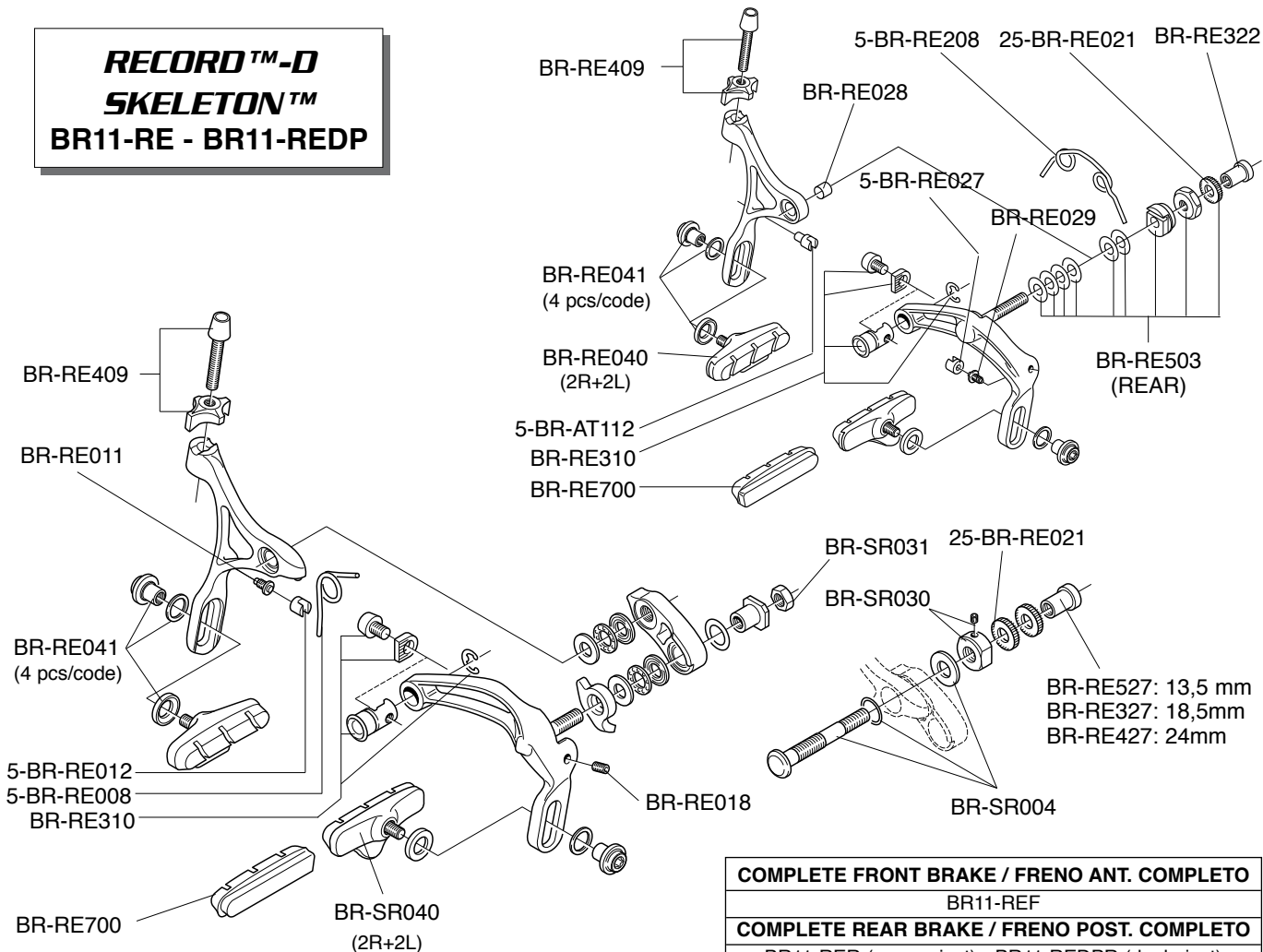

COMPLETE FRONT BRAKE / FRENO ANT. COMPLETO
BR11-REF
COMPLETE REAR BRAKE / FRENO POST. COMPLETO
BR11-RER (mono pivot) - BR11-REDPR (dual pivot)

CHORUS™-D
SKELETON™
BR11-CH - BR11-CHDP

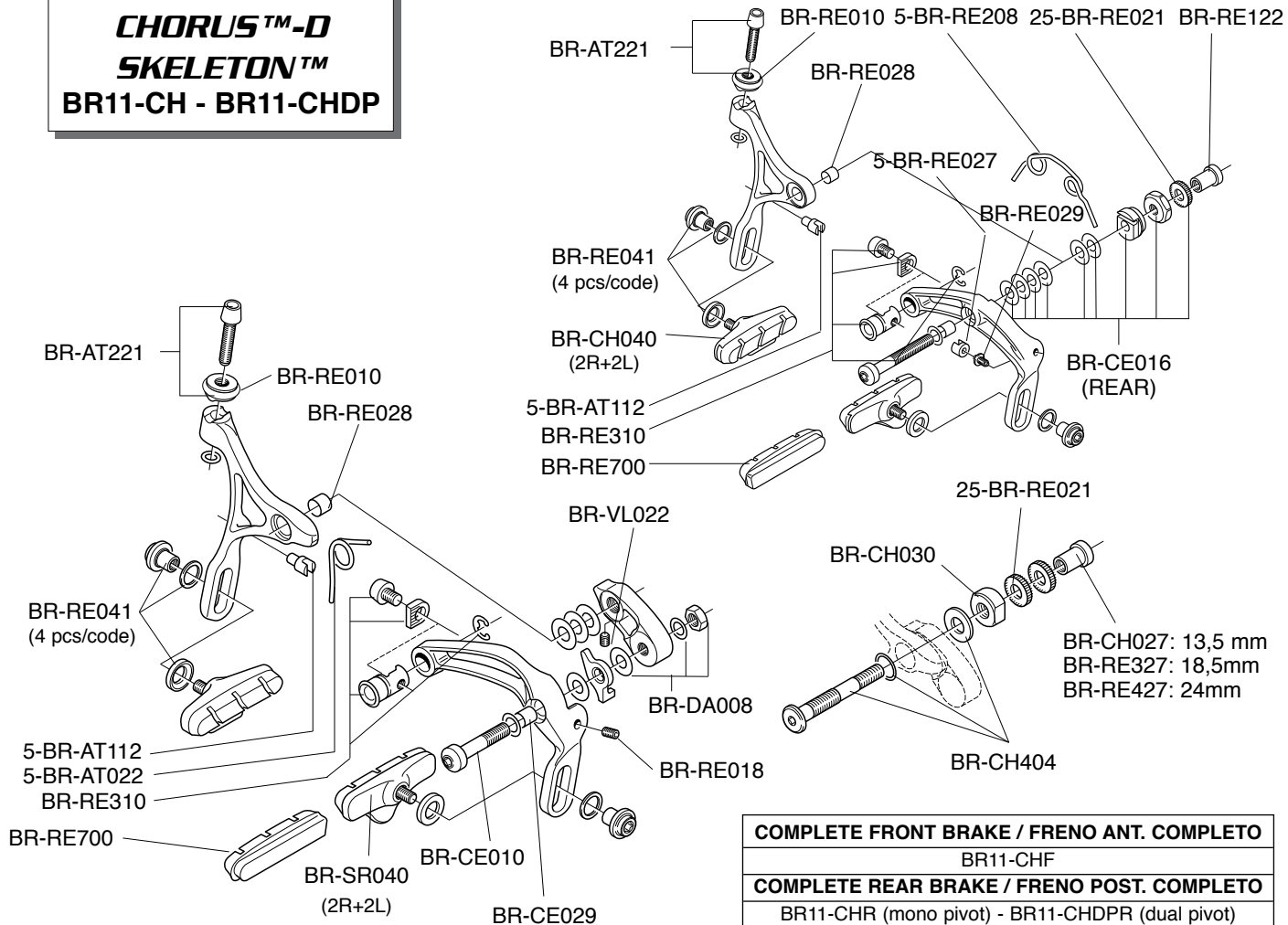

COMPLETE FRONT BRAKE / FRENO ANT. COMPLETO
BR11-CHF
COMPLETE REAR BRAKE / FRENO POST. COMPLETO
BR11-CHR (mono pivot) - BR11-CHDPR (dual pivot)

ATHENA™-D
SKELETON™
BR11-AT - BR11-ATDP

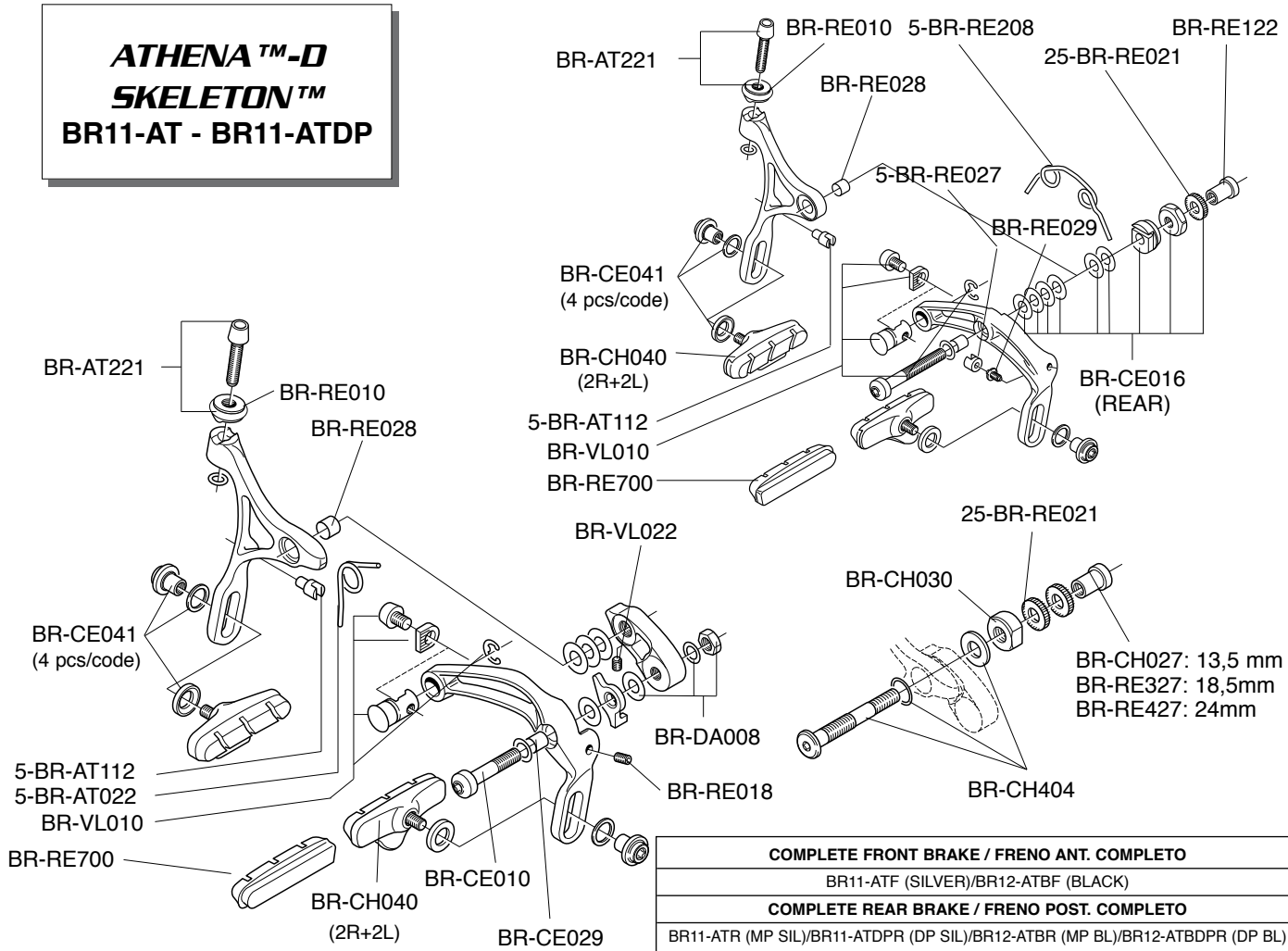

COMPLETE FRONT BRAKE / FRENO ANT. COMPLETO

BR11-ATF (SILVER)/BR12-ATBF (BLACK)

COMPLETE REAR BRAKE / FRENO POST. COMPLETO

BR11-ATR (MP SIL)/BR11-ATDPR (DP SIL)/BR12-ATBR (MP BL)/BR12-ATBDPR (DP BL)

CENTAUR™
BR11-CE
VELOCE™
BR11-VL

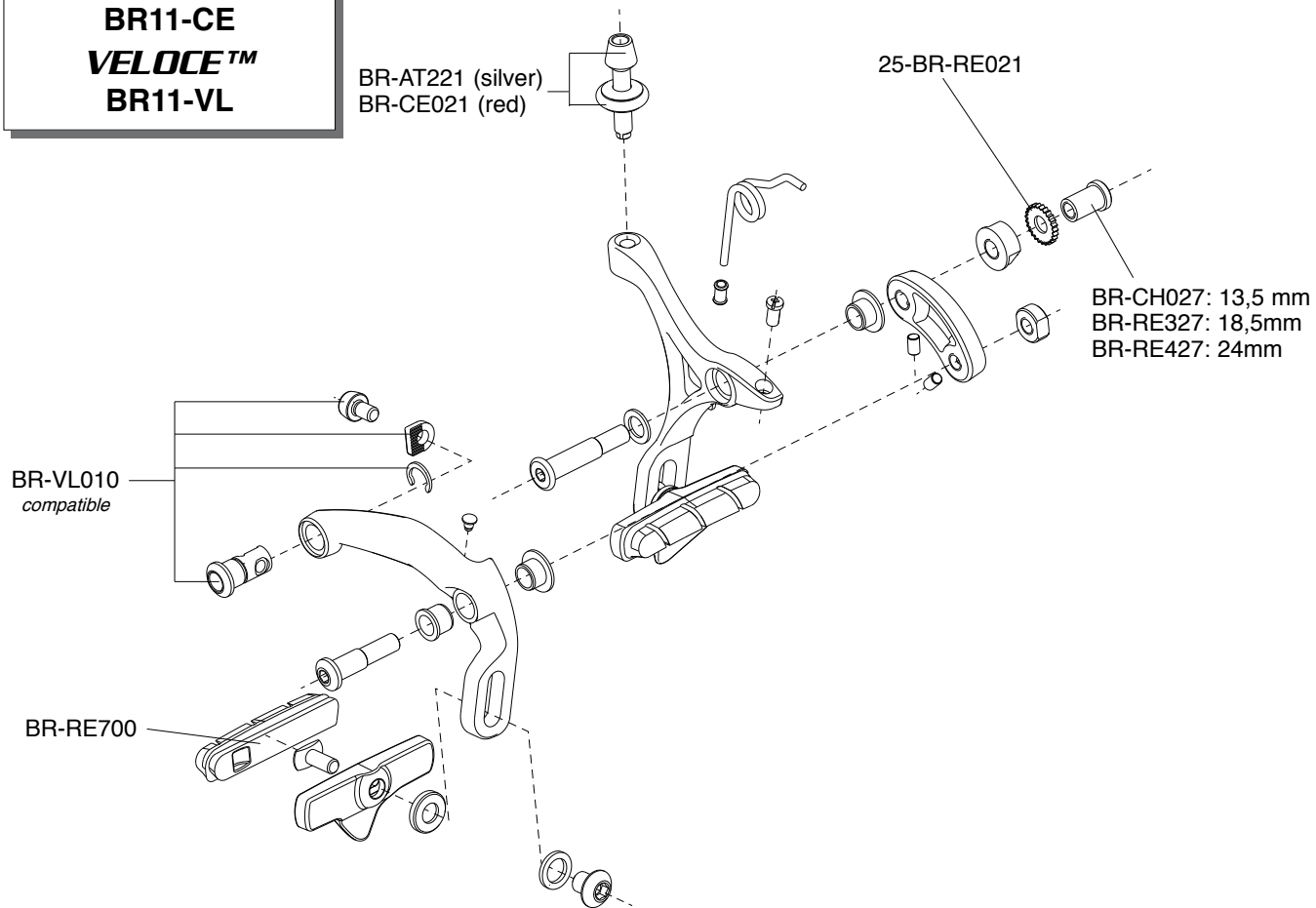

CX™ CANTILEVER

BRAKES

BR12-CXS (silver)

BR12-CXB (black)

COMPLETE FRONT BRAKE / FRENO ANT. COMPLETO

BR12-CXSF (SILVER)/BR12-CXBF (BLACK)

COMPLETE REAR BRAKE / FRENO POST. COMPLETO

BR12-CXSR (SILVER)/BR12-CXSR (BLACK)

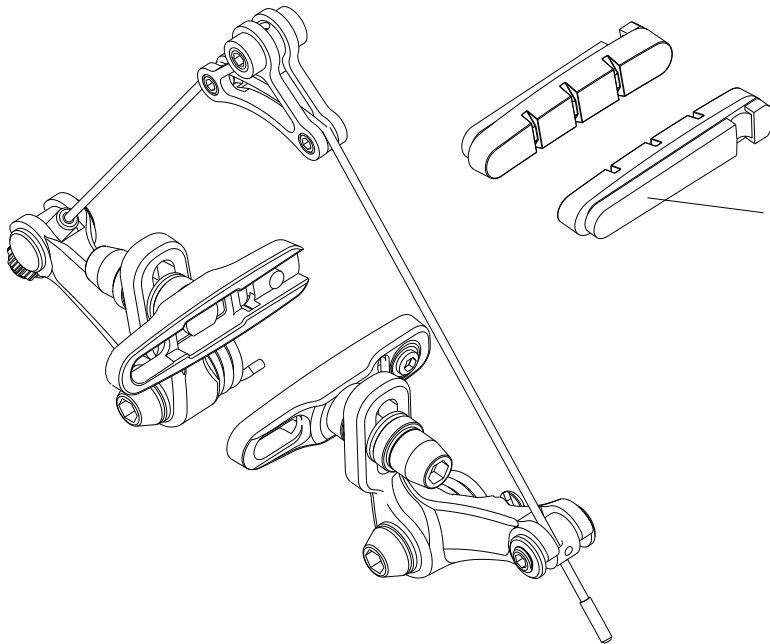

BR-CX500

(4 pcs - for alu rims - Dura-Ace compatible)

BR-BO500X

(4 pcs - for carbon rims - Dura-Ace compatible)

BAR-END TT

10s: SL12-TT10CG (alu)

11s: SL12-TT11CG (alu)

SL12-TT11CGC (carbon)

R.H. COMPLETE CONTROL LEVER / COMANDO DX COMPLETO

SL12-TT10R - SL12-TT11R - SL12-TT11CR

L.H. COMPLETE CONTROL LEVER / COMANDO SX COMPLETO

SL12-TT10L - SL12-TT11L - SL12-TT11CL

CABLES & CASINGS / CAVI E GUAINA

CG-SL500

R: SL-TT003 (A) - SL-TT003C (C)
L: SL-TT004 (A) - SL-TT004C (C)

R: SL-TT005 (10s) - SL-TT007 (11s)
L: SL-TT006

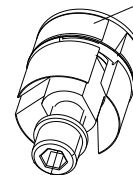
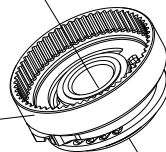
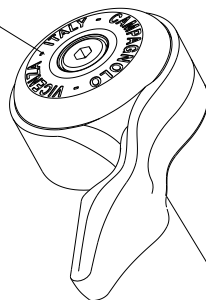

SL-TT008

SL-TT001 right
SL-TT002 left

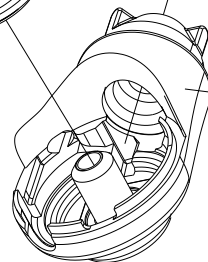

BRAKE LEVERS TT
BL12-TTCG (alu)
BL12-TTCGC (carbon)

R.H. COMPLETE BRAKE LEVER / LEVA FRENO DX COMPLETA

BL12-TTCR (carbon) - BL12-TTR (alu)

L.H. COMPLETE BRAKE LEVER / LEVA FRENO SX COMPLETA

BL12-TTCL (carbon) - BL12-TTL (alu)

CABLES & CASINGS / CAVI E GUAINA

CG-BL500

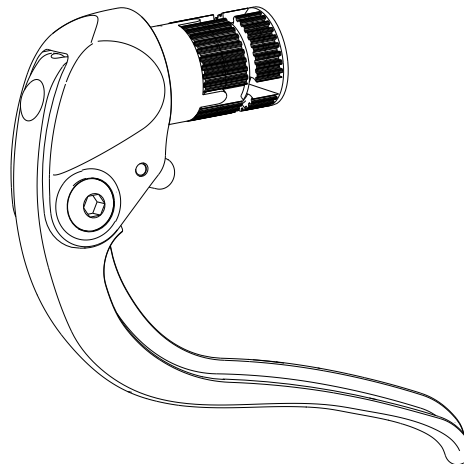
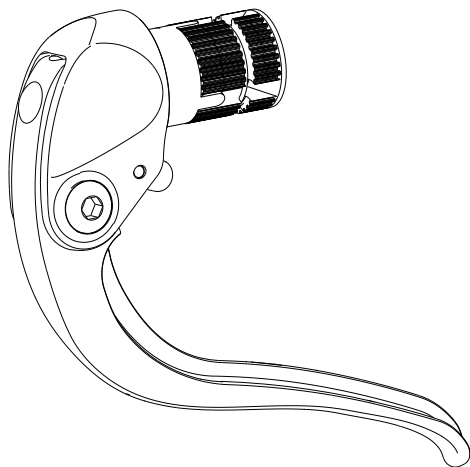

TT™
FRONT BRAKE
BR12-TTFLP

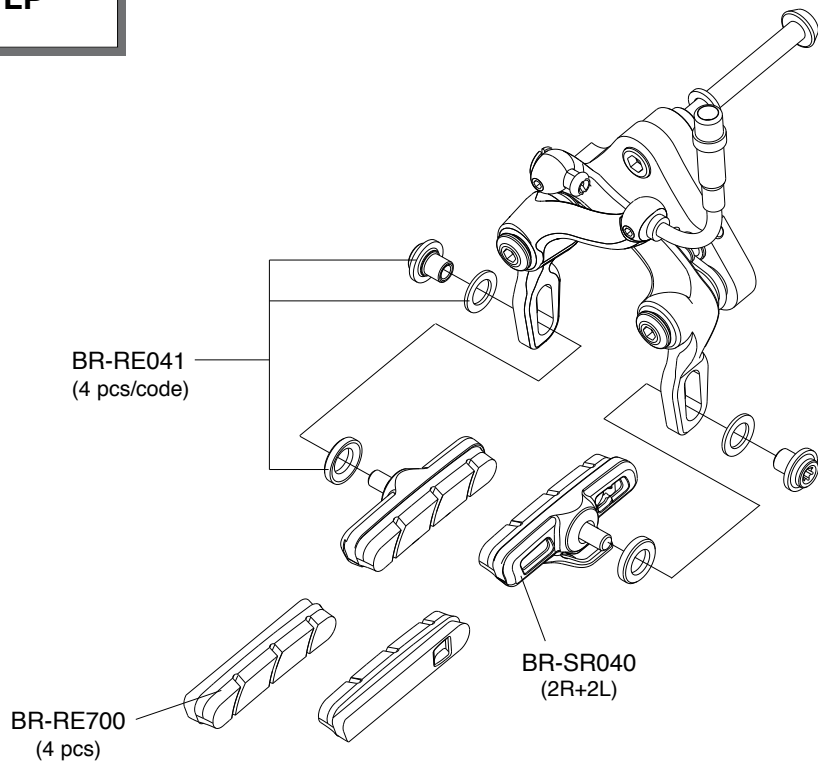

TT™

REAR BRAKES

BR12-TTRLP (central pull)

BR12-TTRCP (lateral pull)

CENTRAL PULL

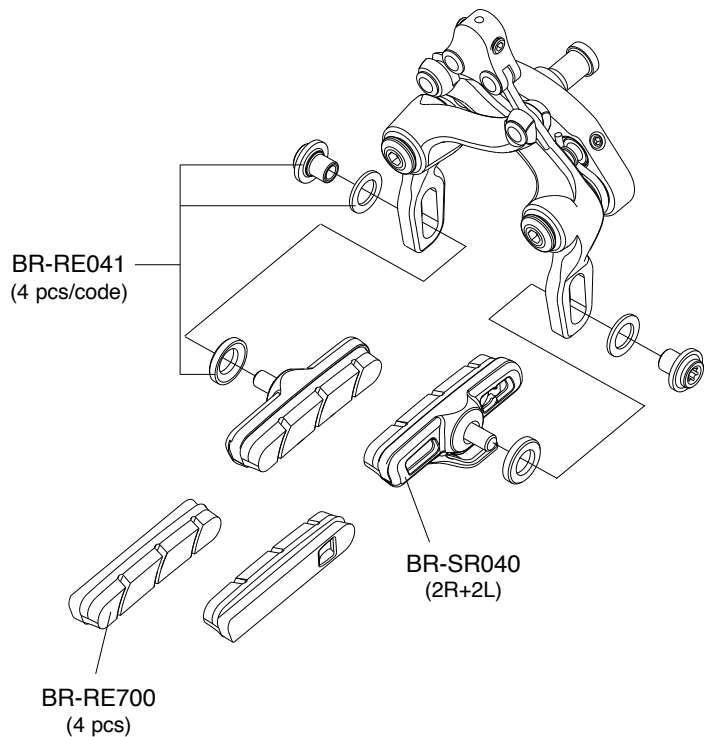

LATERAL PULL

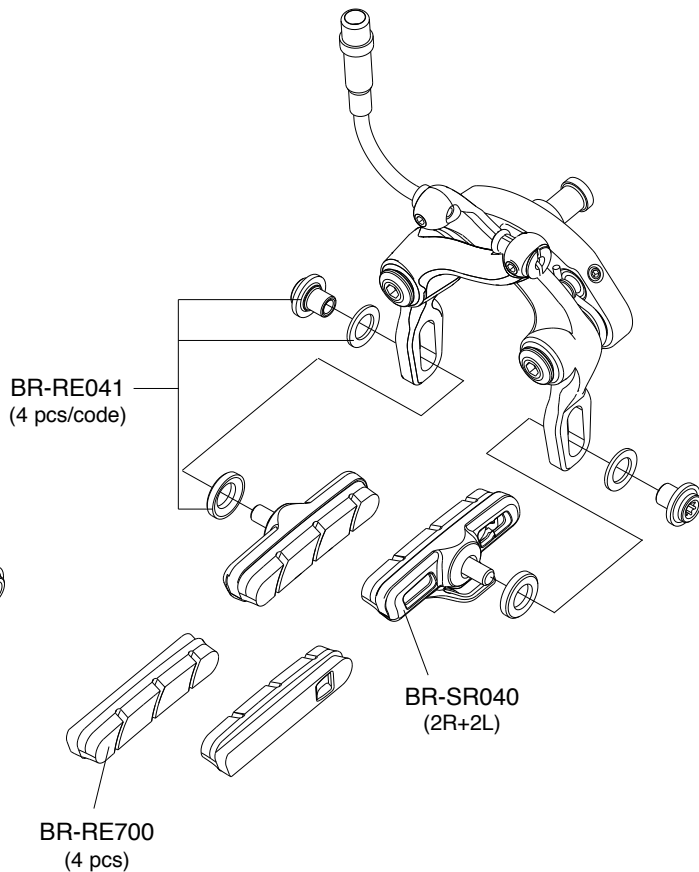

QR11-20BFR

(front + rear)

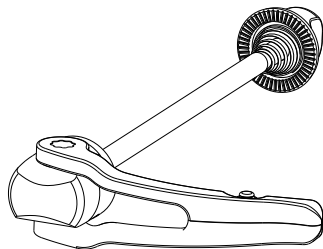

8-QF-RE108

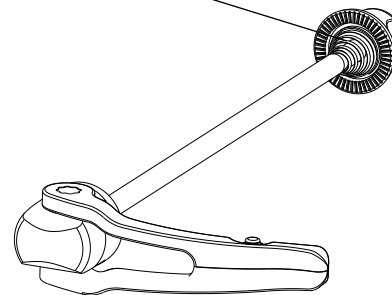

nuovi bloccaggi?

QR8-40BFR

(front + rear)

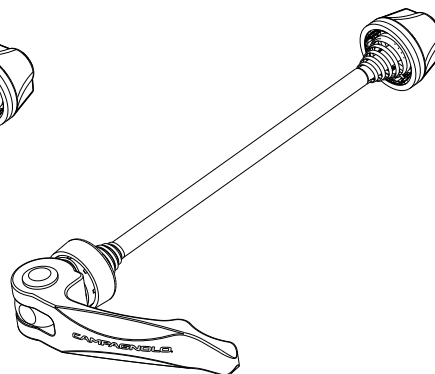
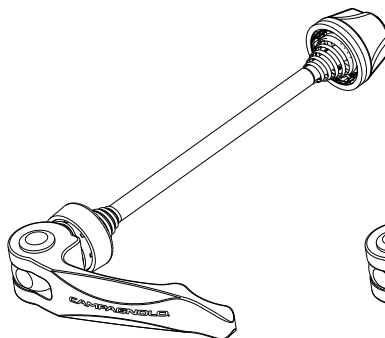

RECORD™
HB7-RE2

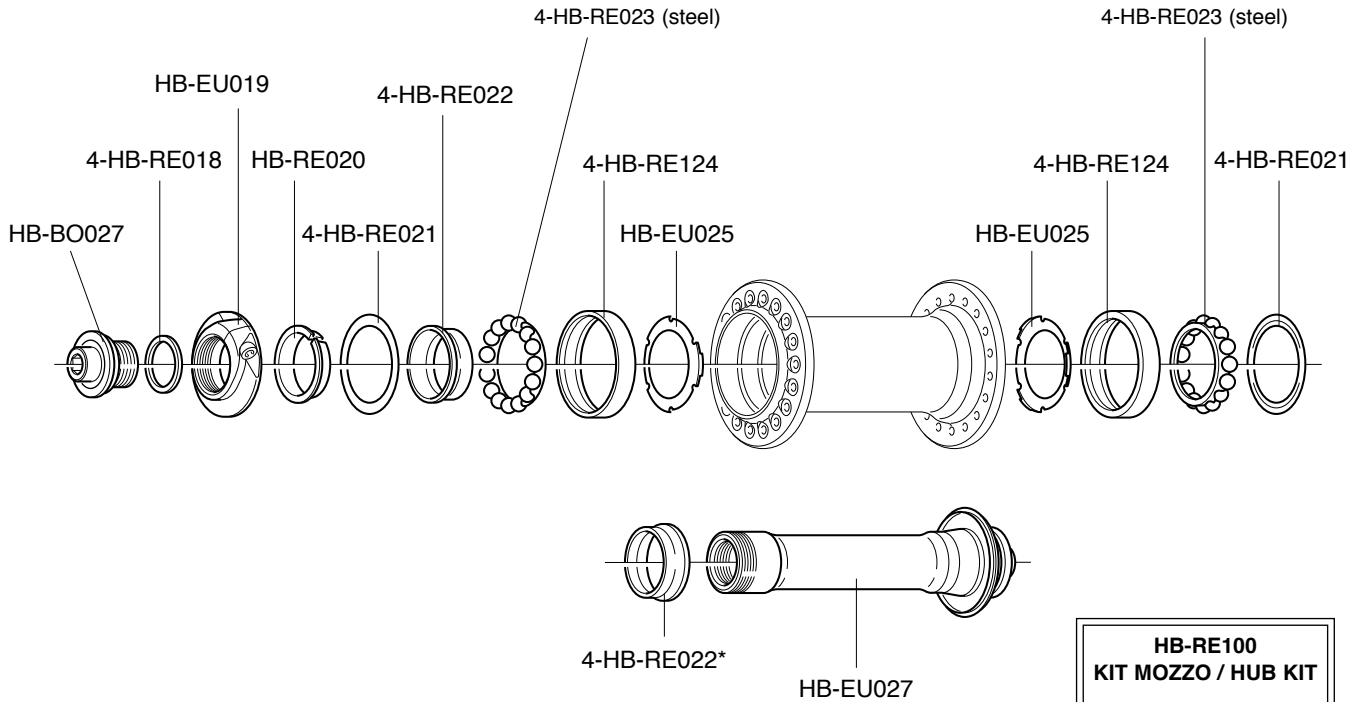

- HB-RE100**
KIT MOZZO / HUB KIT
- 2 x HB-RE021
 - 2 x HB-RE022
 - 2 x HB-RE124
 - 2 x HB-RE023

RECORD™
9s/10s/11s
FH7-RE2

- HB-RE100**
KIT MOZZO / HUB KIT
- 2 x HB-RE021
 - 2 x HB-RE022
 - 2 x HB-RE124
 - 2 x HB-RE023

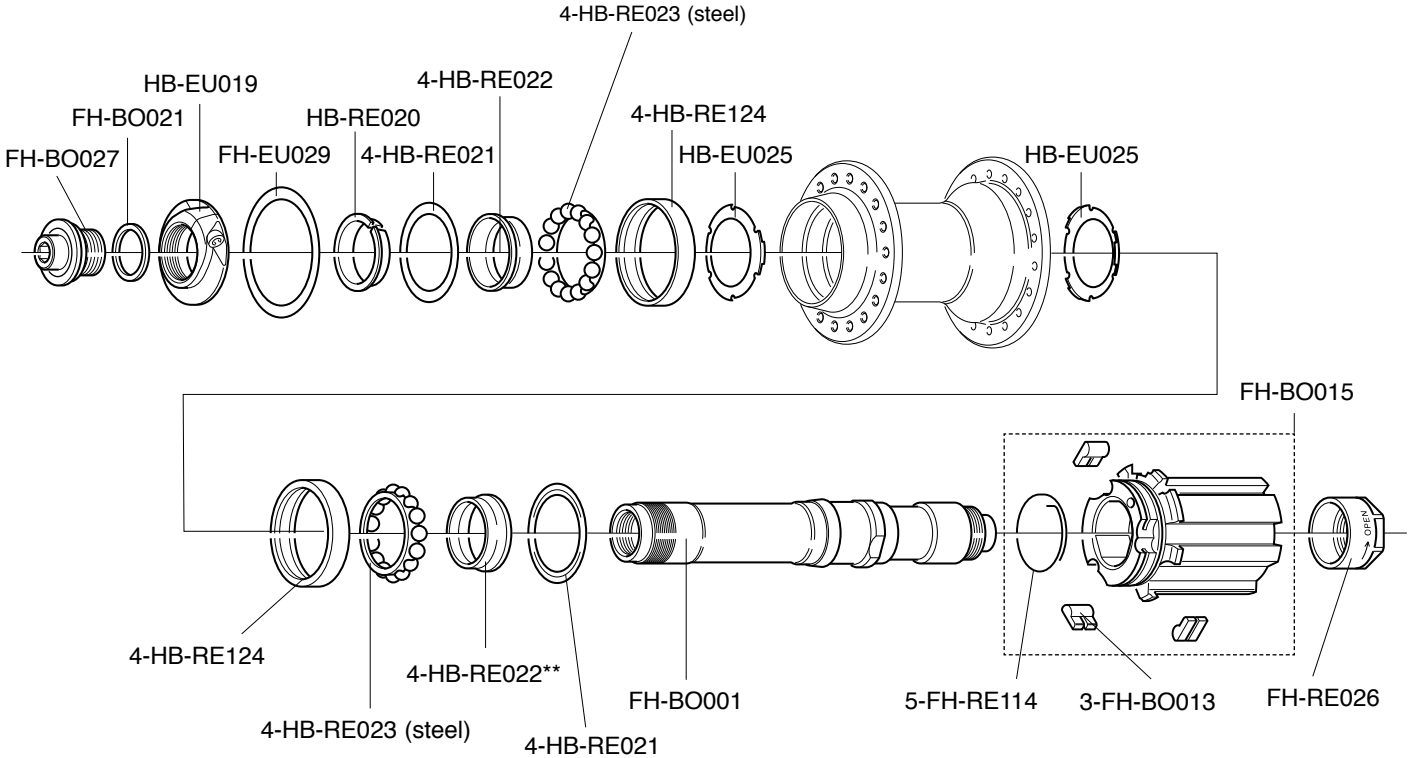

RECORD™
PISTA™
HB02-REPI..

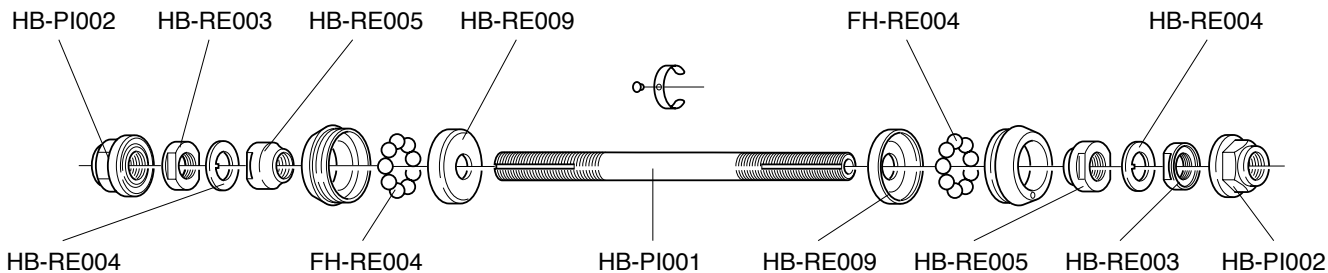
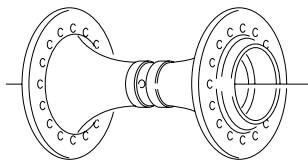

RECORD™
PISTA™
FH02-REPI..

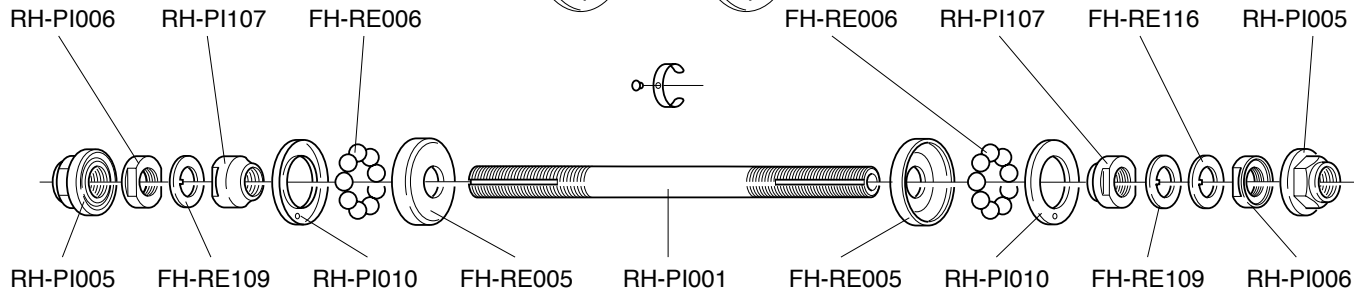
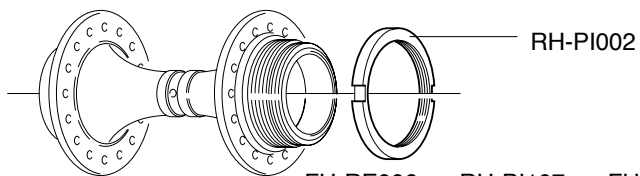

GHIERE / LOCKRINGS / ECROUS / VERSCHLUSSRING

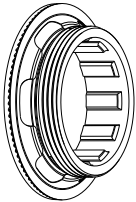
	CODE CODICE	TYPE TIPO	RANGE GAMMA	HUB COMPATIBILITY COMPATIBILITÀ MOZZI	
	CS-401	<i>9s / 10s</i> "oversize" thread/fil.: 27 x 1	steel / acciaio	2000 e succ. 2000 and following	all groups / tutti i gruppi all wheels / tutte le ruote
				1999	RECORD™ - CHORUS™ all wheels / tutte le ruote
	CS-501	<i>9s / 10s</i> "oversize" thread/fil.: 27 x 1	steel / acciaio (for Z. 11)	2000 e succ. 2000 and following	all groups / tutti i gruppi all wheels / tutte le ruote
				1999	RECORD™ - CHORUS™ all wheels / tutte le ruote
CS-701	for sprockets/ per pignoni HG 10s thread/fil.: 27 x 1	steel / acciaio	2007-2008	all Campagnolo® wheels with HG 10 type FW body / tutte le ruote Campagnolo® con corpetto RL tipo HG 10	
CS-801	for sprockets/ per pignoni HG 10s thread/fil.: 27 x 1	steel / acciaio (for Z. 11)	2007-2008	all Campagnolo® wheels with HG 10 type FW body / tutte le ruote Campagnolo® con corpetto RL tipo HG 10	
	CS-112	<i>11</i> [™] SPEED only thread/fil.: 27 x 1	alloy / alluminio	2009	only 11s sprocket sets / solo pacchi pignoni 11s
	CS-111	<i>11</i> [™] SPEED only thread/fil.: 27 x 1	alloy / alluminio (for Z. 11)	2009	only 11s sprocket sets / solo pacchi pignoni 11s

SUPER RECORD™

11s CS9-SR1...

* pre-assembled

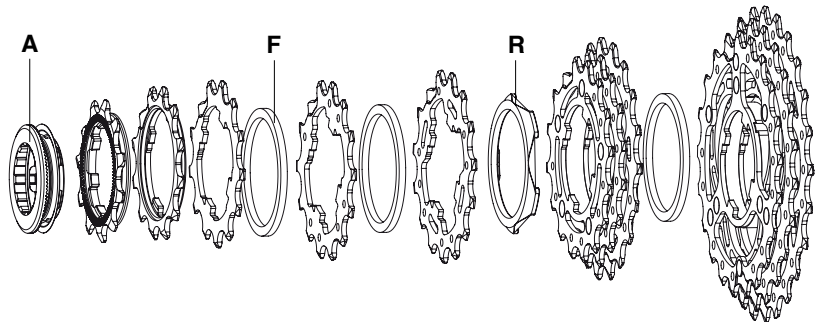

11-23	A	11A-1°	12A-2°	13A	F	14A	F	15A	R	16A-17A-18A*	F	19A-21A-23A*
		11S-011	11S-022	11S-131		11S-141		11S-151		11S-678T		11S-913T
11-25	A	11A-1°	12A-2°	13A	F	14A	F	15A	R	16A-17A-19B*	F	21B-23B-25B*
		11S-011	11S-022	11S-131		11S-141		11S-151		11S-679T		11S-135BT

A	CS-112	11s only
	CS-111	11s only (for Z 11)
F	2-CS-612 (2 pcs)	2,2 mm
R	2-CS-712 (2 pcs)	2,3 mm

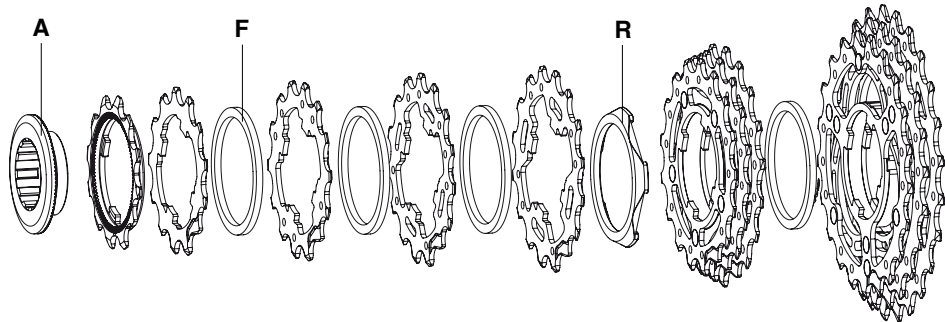

12-25	A	12A-1°	13A	F	14A	F	15A	F	16A	R	17A-18A-19A*	F	21A-23A-25A*
		11S-012	11S-131		11S-141		11S-151		11S-161		11S-789T		11S-135AT
12-27	A	12A-1°	13A	F	14A	F	15A	F	16A	R	17A-19B-21B*	F	23B-25B-27B*
		11S-012	11S-131		11S-141		11S-151		11S-161		11S-791T		11S-357T
12-29	A	12A-1°	13A	F	14A	F	15A	F	16A	R	17A-19B-21B*	F	23B-26C-29C*
		11S-012	11S-131		11S-141		11S-151		11S-161		11S-791T		11S-369T

RECORD™
11s
CS9-RE1...

* pre-assembled

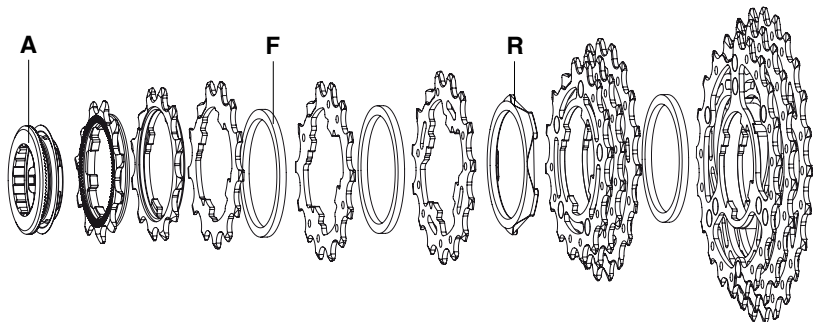

11-23	A	11A-1°	12A-2°	13A	F	14A	F	15A	R	16A-17A-18A*	F	19A-21A-23A*
		11S-011	11S-022	11S-131		11S-141		11S-151		11S-678		11S-913T
11-25	A	11A-1°	12A-2°	13A	F	14A	F	15A	R	16A-17A-19B*	F	21B-23B-25B*
		11S-011	11S-022	11S-131		11S-141		11S-151		11S-679		11S-135BT

A	CS-112	<i>11s only</i>
	CS-111	<i>11s only</i> (for Z 11)
F	2-CS-612 (2 pcs)	2,2 mm
R	2-CS-712 (2 pcs)	2,3 mm

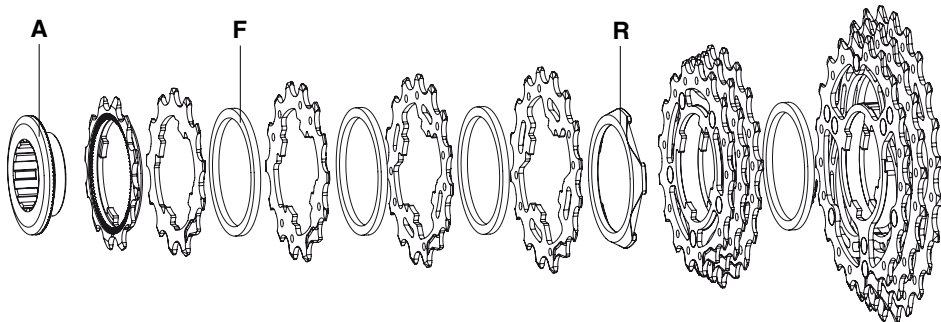

12-25	A	12A-1°	13A	F	14A	F	15A	F	16A	R	17A-18A-19A*	F	21A-23A-25A*
		11S-012	11S-131		11S-141		11S-151		11S-161		11S-789		11S-135AT
12-27	A	12A-1°	13A	F	14A	F	15A	F	16A	R	17A-19B-21B*	F	23B-25B-27B*
		11S-012	11S-131		11S-141		11S-151		11S-161		11S-791		11S-357T
12-29	A	12A-1°	13A	F	14A	F	15A	F	16A	R	17A-19B-21B*	F	23B-26C-29C*
		11S-012	11S-131		11S-141		11S-151		11S-161		11S-791		11S-369T

CHORUS™

11s
CS9-CH1...

* pre-assembled

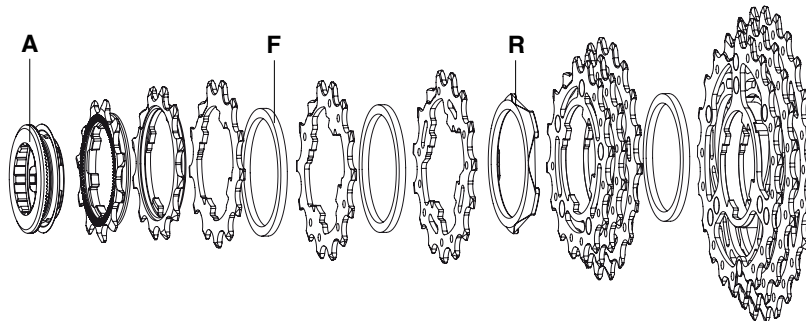

11-23	A	11A-1°	12A-2°	13A	F	14A	F	15A	R	16A-17A-18A*	F	19A-21A-23A*
		11S-011	11S-022	11S-131		11S-141		11S-151		11S-678		11S-913
11-25	A	11A-1°	12A-2°	13A	F	14A	F	15A	R	16A-17A-19B*	F	21B-23B-25B*
		11S-011	11S-022	11S-131		11S-141		11S-151		11S-679		11S-135B

A	CS-112	<i>11s only</i>
	CS-111	<i>11s only</i> (for Z 11)
F	2-CS-612 (2 pcs)	2,2 mm
R	2-CS-712 (2 pcs)	2,3 mm

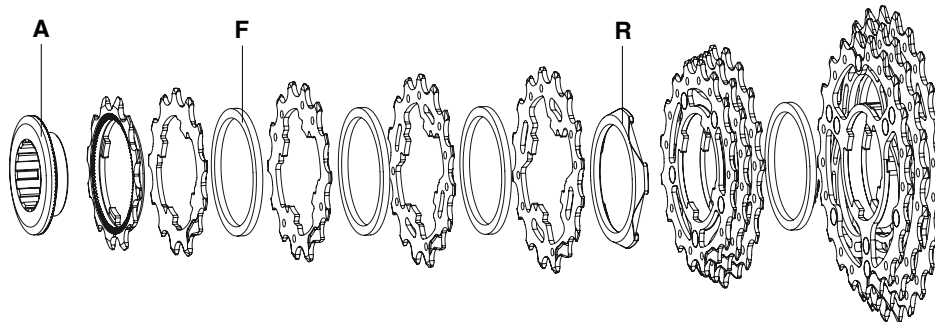

12-25	A	12A-1°	13A	F	14A	F	15A	F	16A	R	17A-18A-19A*	F	21A-23A-25A*
		11S-012	11S-131		11S-141		11S-151		11S-161		11S-789		11S-135A
12-27	A	12A-1°	13A	F	14A	F	15A	F	16A	R	17A-19B-21B*	F	23B-25B-27B*
		11S-012	11S-131		11S-141		11S-151		11S-161		11S-791		11S-357
12-29	A	12A-1°	13A	F	14A	F	15A	F	16A	R	17A-19B-21B*	F	23B-26C-29C*
		11S-012	11S-131		11S-141		11S-151		11S-161		11S-791		11S-369

CENTAUR™
UD™ 10s
CS9-CEX43
CS11-CEX..

DISTANZIALI / SPACERS

G = CS-602 (2,55 mm)

M = CS-606 (3,05 mm)

N = CS-607 (2,4 mm)

O = CS-609 (2,55 mm)

P = CS-608 (1,6 mm)

Q = CS-610 (2,4 mm)

VELOCE 10s compatible

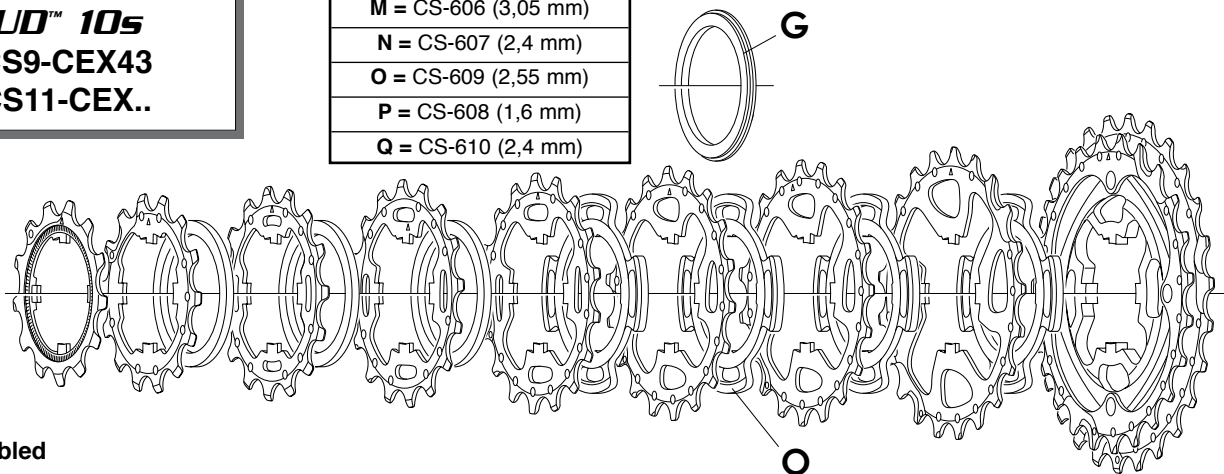

* pre-assembled

11 - 23	11A-1° 10S-011	12A-2° 10S-022	13A 10S-131	Q	14A 10S-141	Q	15A 10S-151	Q	16A 10S-161	G	17A 10S-171	N	19A 10S-191	M	21A-23A* 10S-13A			
11 - 25	11A-1° 10S-011	12A-2° 10S-022	13A 10S-131	Q	14A 10S-141	Q	15A 10S-151	Q	17G 10S-177	O	19G 10S-197	N	21G 10S-217	M	23G-25G* 10S-35G			
12 - 25	12A-1° 10S-032	13A 10S-131	Q	14A 10S-141	Q	15A 10S-151	Q	16A 10S-161	Q	17A 10S-171	O	19A 10S-191	N	21A 10S-211	M	23A-25A* 10S-35A		
13 - 26	13A-1° 10S-023	14A 10S-141	Q	15A 10S-151	Q	16A 10S-161	Q	17A 10S-171	N	18C 10S-183	O	19C 10S-193	N	21C 10S-213	M	23C-26C* 10S-36C		
13 - 29	13A-1° 10S-023	14A 10S-141	Q	15A 10S-151	Q	16A 10S-161	Q	17A 10S-171	N	19A 10S-191	O	21A 10S-211	N	23A 10S-231	M	26A-29A* 10S-69A		
14 - 23	14A-1° 10S-014	15A 10S-151	Q	16A 10S-161	Q	17A 10S-171	Q	18C 10S-183	N	19C 10S-193	O	20D 10S-204	N	21D 10S-214	N	22D 10S-224	P	23D 10S-234

GHIBLI™
 (11s drivetrain)
 CS12-GH1111
 CS12-GH1113

A CS-111 *11s only*
 (for Z 11)

R 2-CS-712
 (2 pcs) 2,3 mm

F 2-CS-612
 (2 pcs) 2,2 mm

S CS-613
 (2 pcs) 2,5 mm

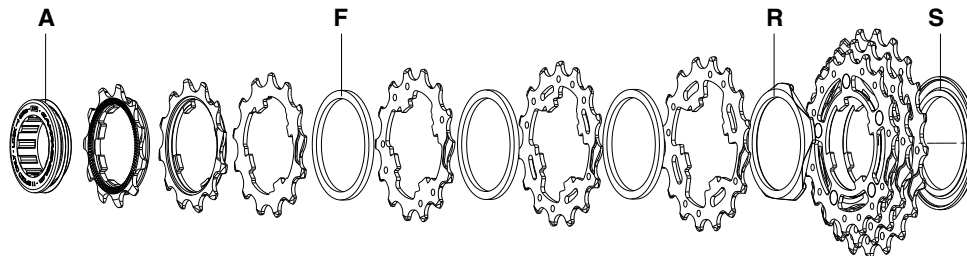

11-21	A	11A-1°	12A-2°	13A	F	14A	F	15A	F	16A	R	17A-19A-21A*	S
		11S-011	11S-022	11S-131		11S-141		11S-151		11S-161		11S-791	

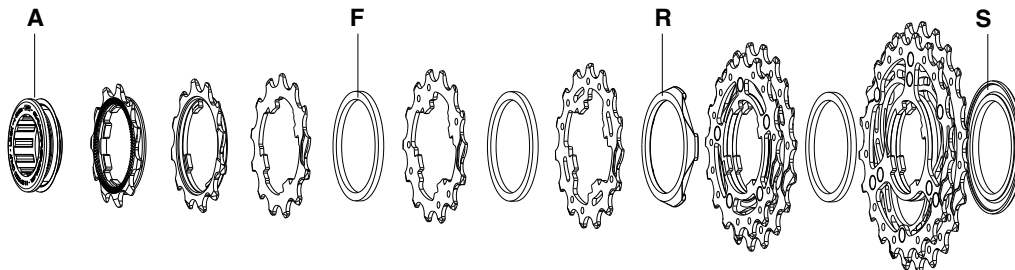

11-23	A	11A-1°	12A-2°	13A	F	14A	F	15A	R	17A-19A*	F	21A-23A*	S
		11S-011	11S-022	11S-131		11S-141		11S-151		11S-79GH		11S-13GH	

**PRO-FIT™ /
PRO-FIT PLUS™
SPARE PARTS**

R + L: PD-RE105

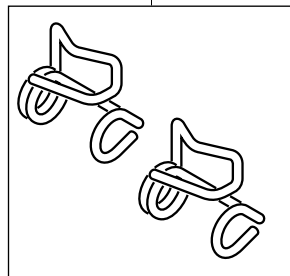

PD-RE116

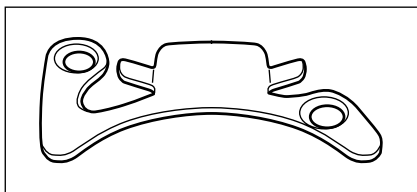
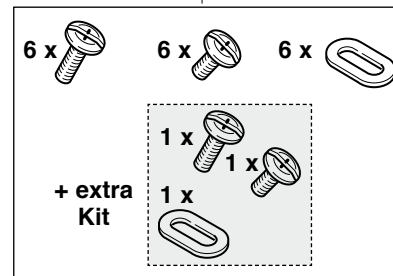

**PRO-FIT™
PD-RE111**

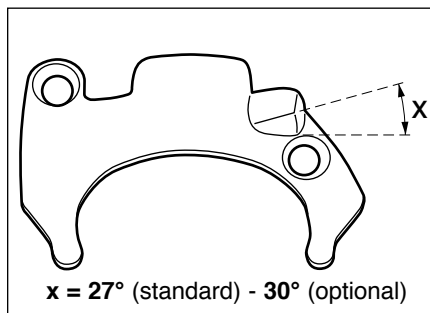

PRO-FIT PLUS™
PD-RE110: standard - 27°
PD-RE109: HRE - optional - 30°

**PRO-FIT™ /
PRO-FIT PLUS™
SPARE PARTS**

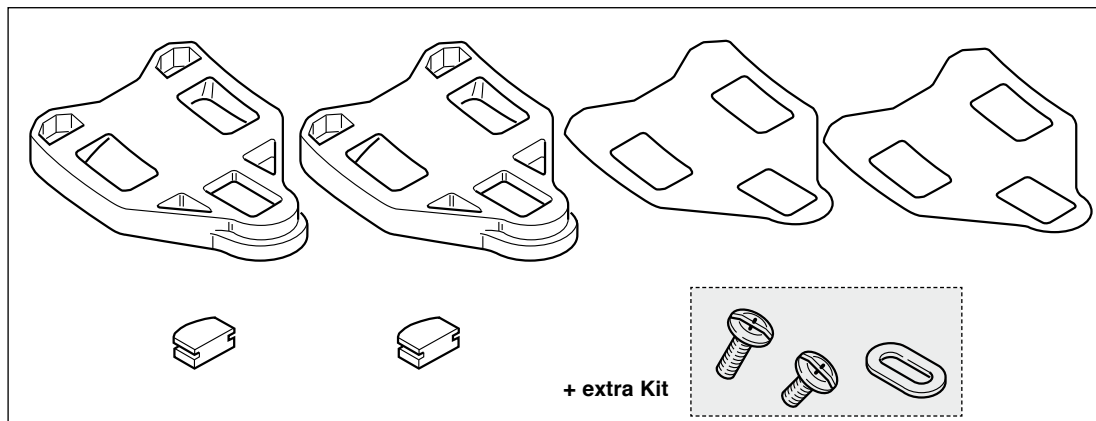
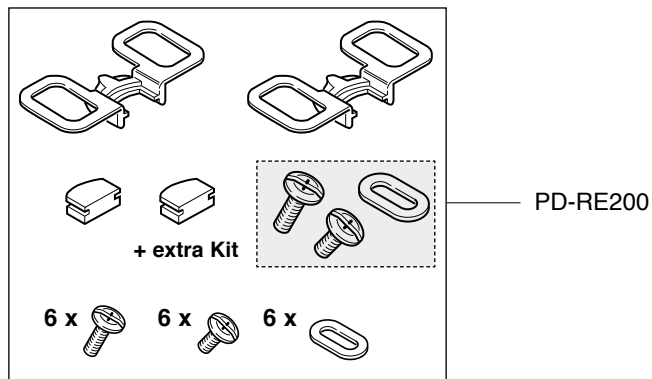

PD-RE020 FLOATING CLEATS - PD-RE021 FIXED CLEATS

CABLES & CASINGS for ULTRA-SHIFT™ & POWER-SHIFT™ ERGOPOWER

**COMPLETE
SET**

BLACK





CG-ER600

WHITE

CG-ER600W

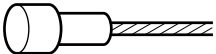

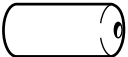

RED

CG-ER600R

		FRONT	REAR
BRAKES		Ø 1,6 mm L. 800 mm CG-CB003	Ø 1,6 mm L. 1600 mm 10-CG-CB013 (10 pcs.)
DERAILLEURS			L. 1600 CG-CB014
	Ø 1,2 mm		L. 2000 10-CG-CB009 (10 pcs.)
			Ø 5,7 mm 10-CG-CS112 (for CG-CS115 and CG-CS108 - sealed / con guarnizione - 10 pcs.)
		Ø 5,7/4 mm 5-CG-CS113 (for CG-CS115 and CG-CS108 - sealed / con guarnizione - 5 pcs.)	

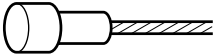
CABLES & CASINGS for all Ergopower™ control levers (except for ULTRA-SHIFT™)

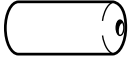
Complete set: CG-ER500

		FRONT	REAR	
BRAKES		Ø 1,6 mm L. 800 mm CG-CB003	Ø 1,6 mm L. 1600 mm 10-CG-CB013 (10 pcs.)	
		Ø 6 mm 10-CG-CS011 (10 pcs.) (not sealed / senza guarnizione)		
DERAILLEURS		ERGOPOWER	L. 1600	CG-CB014
	Ø 1,2 mm	ERGOPOWER	L. 2000	10-CG-CB009 (10 pcs.)
		Ø 5,7 mm 10-CG-CS012 (for CG-CS015 and CG-CS008 - sealed / con guarnizione - 10 pcs.)		
	Ø 5,7/4 mm 5-CG-CS013 (for CG-CS015 and CG-CS008 - sealed / con guarnizione - 5 pcs.)			

TRADITIONAL LEVERS: CG-BR201 (brakes) - CG-DD101 (derailleurs)



LB-100 (1 pc.)
10-LB-100 (10 pcs.)
Grease 100 gr.

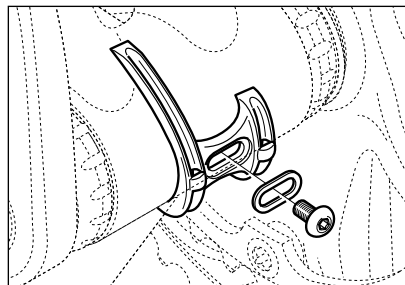

4-PL6-RE
RECORD™
cable guide plate (resin)

BOTTOM BRACKET

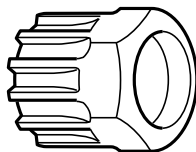

UT-BB080 (1 pz.) - 10-UT-BB080 (10 pz.):

Chiave per montaggio movimenti centrali CART e ghiera di chiusura pacchi pignoni

Cartridge bottom bracket and sprocket cassette- lock ring remover

Clé pour montage jeux de pédalier CART et roues-libres à cassette

Schlüssel zur Montage von Patronen-Tretlager und Schließring für Freilaufzahnkranz

UT-BB100

Utensile per movimenti a cartuccia Daytona/Centaur™, Veloce™ e Mirage™

Tool for Daytona/Centaur™, Veloce™ and Mirage™ cartridge bottom bracket

Clé pour jeux de pédalier à cartouche Daytona/Centaur™, Veloce™ et Mirage™

Montageschlüssel für Daytona/Centaur™, Veloce™ und Mirage™ Patronen-Tretlager

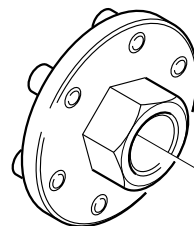

FRAME PREPARATION

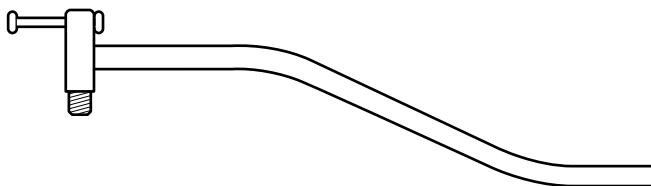

UT-VS030

Riscontro allineamento occhiello attacco cambio
Rear derailleur hanger alignment tool
Calibre de contrôle attache de dérailleur arrière
Richtwerkzeug zur Kontrolle von Ausfallende mit Schaltauge

INSERT FOR LEFT POWER TORQUE™ CRANK EXTRACTOR

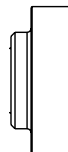

UT-FC090

Inserto per estrattore pedivella sinistra Power Torque
Insert for left Power Torque crank extractor
Insert pour extracteur manivelle gauche Power Torque
Einsatz für linken Power Torque Kurbelabzieher

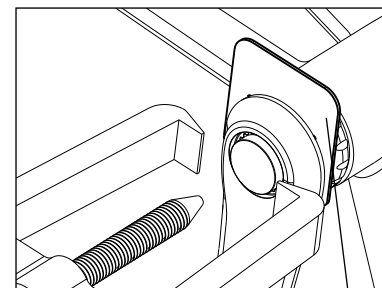

UT-FC095

Protezione per estrazione pedivella sinistra Power Torque (5 pz)
Shield for left Power Torque crank extractor insert (5 pcs)
Ecran insert pour extracteur manivelle gauche Power Torque (5 pcs)
Schutz für insatz für linken Power Torque Kurbelabzieher (5 St.)

CRANKSET

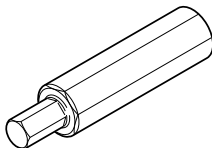

UT-BB110

Utensile per vite fissaggio guarnitura ULTRA-TORQUE™

Tool for ULTRA-TORQUE™ crankset fixing screw

Outil pour vis de fixation pédalier ULTRA-TORQUE™

Werkzeug für ULTRA-TORQUE™ Kettenradgarnitur Befestigungsschraube

UT-BB130

Chiave per calotte esterne guarnitura ULTRA-TORQUE™

Tool for ULTRA-TORQUE™ crankset overboard cups

Outil pour cuvettes pédalier ULTRA-TORQUE™

Werkzeug für ULTRA-TORQUE™ Kettenradgarnitur Lagerschalen

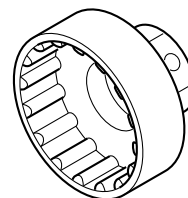

UT-BB140

Utensile per piantaggio calotte integrate ULTRA-TORQUE™ OS-Fit™

Tool for ULTRA-TORQUE™ OS-Fit™ crankset overboard cups

Outil pour cuvettes pédalier ULTRA-TORQUE™ OS-Fit™

Werkzeug für ULTRA-TORQUE™ OS-Fit™ Kettenradgarnitur Lagerschalen

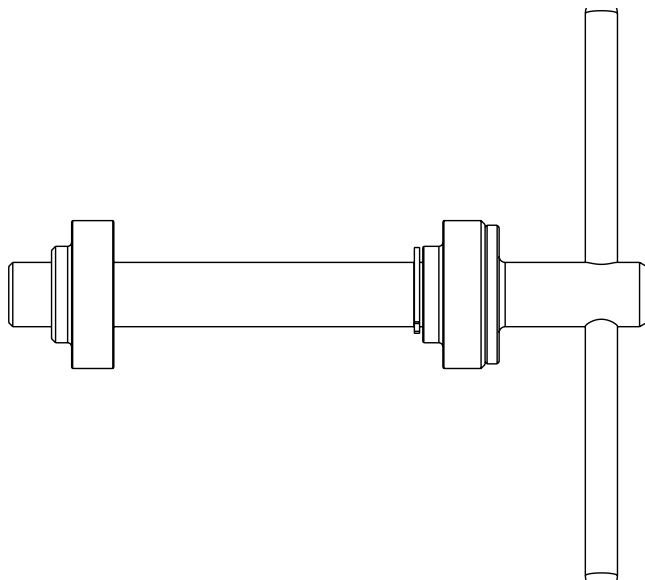
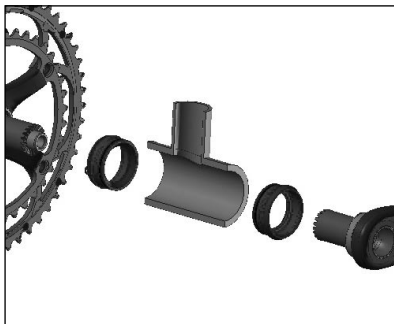

CRANKSET / BRAKES

UT-BR010

Coppia chiavi 13-14 per registrazione freni e coni mozzi

Pair of 13-14 mm spanners for adjusting brakes and hub cones

Paire clés 13-14 pour réglage freins et cônes de moyeux

13-14 mm Schlüssel (2 Stücke) zum Einstellen von Bremsen und Nabelkonusen

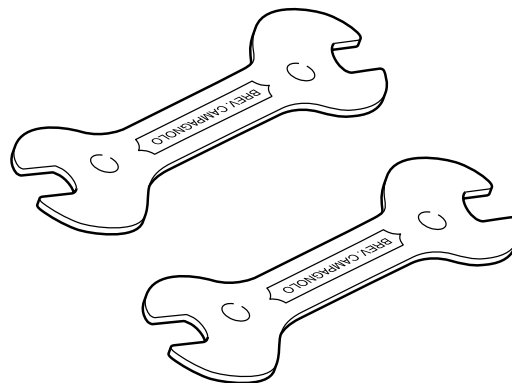

HUBS & WHEELS

UT-HU050

Tiraraggi

Spoke wrench

Clé à rayons

Speichenschlüssel

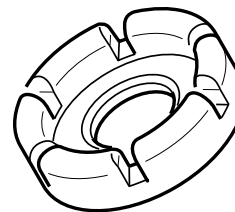

HUBS & WHEELS

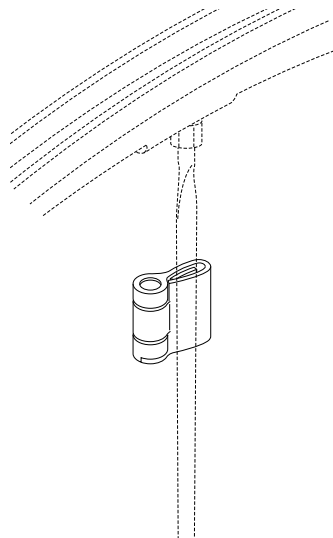

UT-WH080

Magnete velocità per raggi EURUS™ 06 / SHAMAL™ ULTRA™

SPD magnet for EURUS™ 06 / SHAMAL™ ULTRA™ spokes

Aimant vitesse pour rayons EURUS™ 06 / SHAMAL™ ULTRA™

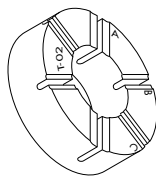

UT-WH010

Anello anti-rotazione raggi
Spoke antirotation ring
Bague antirotation des rayons



UT-WH050

Magnete guida-nipplo
Nipple guide magnet
Aimant de guidage écrou



UT-WH020

Inserto nipplo attira-magnete per EURUS™ 06 / SHAMAL™ ULTRA™

Magnet-attracting nipple insert for EURUS™ 06 / SHAMAL™ ULTRA™

Insert d'écrou pour attirer l'aimant EURUS™ 06 / SHAMAL™ ULTRA™

UT-WH030

Inserto nipplo attira-magnete per ZONDA™ 06
Magnet-attracting nipple insert for ZONDA™ 06
Insert d'écrou pour attirer l'aimant ZONDA™ 06

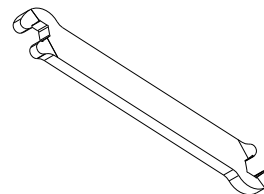

UT-WH070

Chiave tiraraggi
Spoke wrench
Clé à rayons

UT-WH090

Chiave tiraraggi per BULLET ULTRA
Spoke wrench for BULLET ULTRA
Clé à rayons pour BULLET ULTRA

HUBS & WHEELS

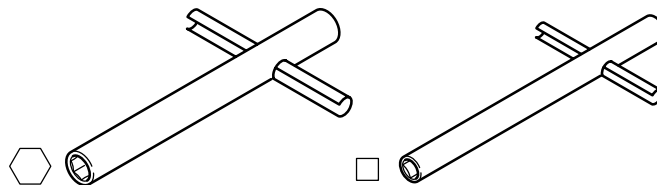

UT-HU070

Chiave con esagono da 5,5 mm per raggi ruote
5,5 mm nut driver for wheel spokes
Clé à rayons de 5,5 mm
5,5 mm Nippelspanner

UT-HU060

Chiave per raggi ruote Bora™ (fino a gamma '02)
Bora™ wheel truing tool (till '02 range)
Clé à rayons pour Bor™a (jusqu'à la gamme '02)
Vierkant-Nippelspanner für Bora™ (bis '02 Produktlinie)

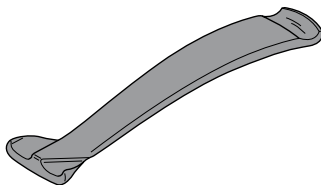

WH-109HYC (6 pcs.)

Leva in composito per rimozione copertoncino
Composite lever for removing clinchers
Démonte-pneus en composite
Reifenheber aus Verbundwerkstoff zum Abnehmen des Drahtreifens

SPROCKETS

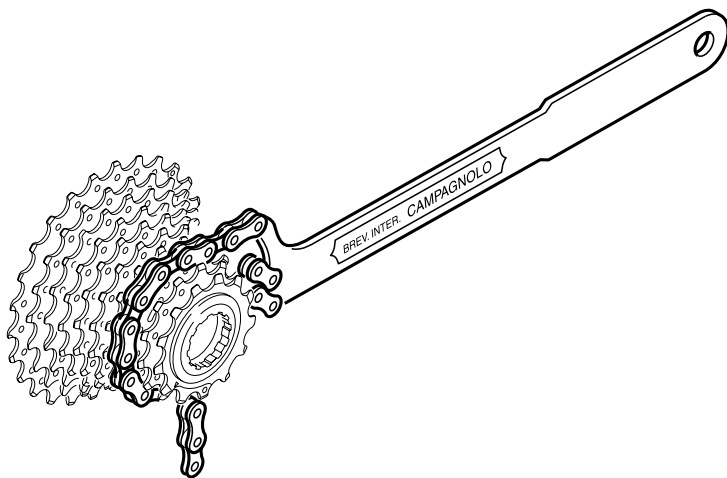

UT-CS060

Chiave con catena 10s per smontaggio pignoni 11s, 10s, 9s e 8s

Spanner with 10s chain for 11, 10, 9 and 8s sprockets

Fouet à chaîne 10s pour pignons 11s, 10s, 9s et 8s

Zahnkranzabnehmer mit Rennkette 10s für 11-, 10-, 9- und 8s Ritzeln



UT-CN303

Perno centrale per UT-CN300 e UT-CN200

Central axle for UT-CN300 and UT-CN200

Axe central pour UT-CN300 et UT-CN200

Achse für UT-CN300 und UT-CN200

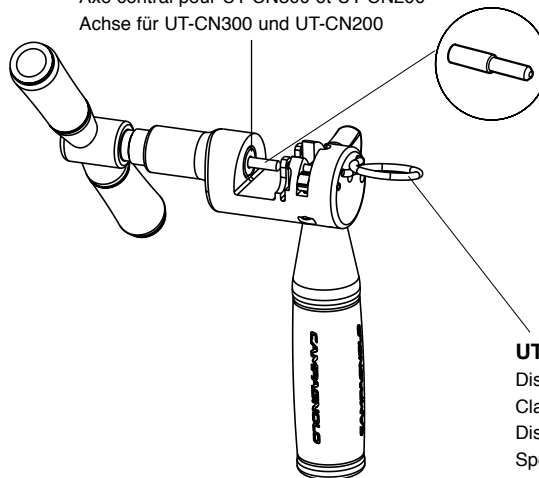

UT-CN301

Spintore per UT-CN300 e UT-CN200

Pusher for UT-CN300 and UT-CN200

Poinçon pour UT-CN300 et UT-CN200

Schieber für UT-CN300 und UT-CN200

UT-CN300

Utensile per **Ultra-Link™** (solo catene 11s)

Tool for **Ultra-Link™** (11s chains only)

Outil pour **Ultra-Link™** (seulement chaînes 11s)

Werkzeug für **Ultra-Link™** (nur 11s Kette)

UT-CN302

Dispositivo di blocco per UT-CN300

Clamping device for UT-CN300

Dispositif de blocage pour UT-CN300

Sperrvorrichtung für UT-CN300

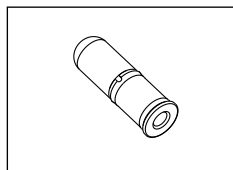

5-CN-RE500

Ultra-Link™ per catene 11s (5 pz)

Ultra-Link™ for 11s chains only (5 pcs)

Ultra-Link™ pour chaînes 11s (5 pcs)

Ultra-Link™ für 11s Kette (5 St.)

10s CHAIN

CAMPY™ UT-CN200

Utensile per **HD-Link™** (catene C10™ e C10™ Ultra Narrow™)
Tool for **HD-Link™** (C10™ and C10™ Ultra Narrow™ chains)
Outil pour **HD-Link™** (chaînes C10™ et C10™ Ultra Narrow™)
Werkzeug für **HD-Link™** (C10™ und C10™ Ultra Narrow™ Kette)

UT-CN303

Perno centrale per UT-CN300 e UT-CN200
Central axle for UT-CN300 and UT-CN200
Axe central pour UT-CN300 et UT-CN200
Achse für UT-CN300 und UT-CN200

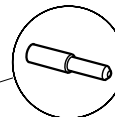

UT-CN301

Spintore per UT-CN300 e UT-CN200
Pusher for UT-CN300 and UT-CN200
Poinçon pour UT-CN300 et UT-CN200
Schieber für UT-CN300 und UT-CN200

UT-CN202

Dispositivo di blocco per UT-CN200
Clamping device for UT-CN200
Dispositif de blocage pour UT-CN200
Sperrvorrichtung für UT-CN200

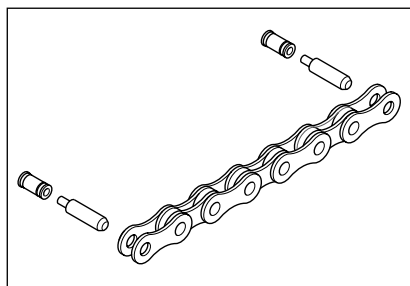
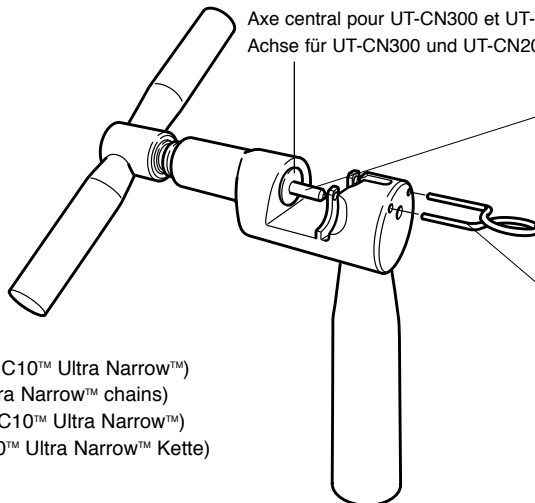

CN-RE400

HD-Link™ Ultra Narrow™ (5,9 mm) per catene C10™ Ultra Narrow™
HD-Link™ Ultra Narrow™ (5,9 mm) for C10™ Ultra Narrow™ chains
HD-Link™ Ultra Narrow™ (5,9 mm) pour chaînes C10™ Ultra Narrow™ chains
HD-Link™ Ultra Narrow™ (5,9 mm) für C10™ Ultra Narrow™ Kette

BIG™ bronze
BIG™ satin

